

TITANUS 25

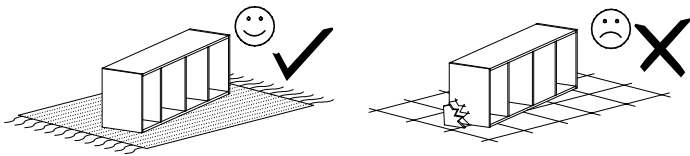

Narzędzia potrzebne do montażu

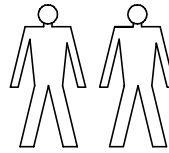
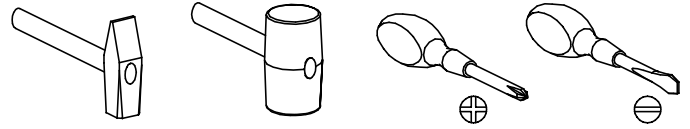

UWAGA !!!

MONTOWANIE USZKODZONYCH
ELEMENTÓW POWODUJE UTRATĘ
GWARANCJI

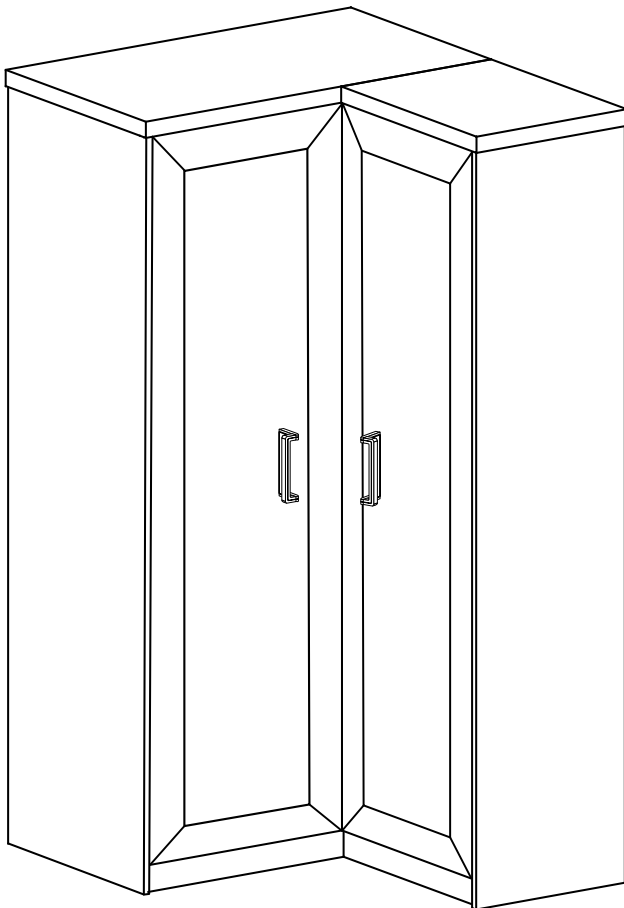

Nr	D[mm]	S[mm]	G[mm]	Ilość
1	506	440	32	1
2	945	575	32	1
3	921	540	16	1
4	520	405	16	1
5	1870	405	16	1
6	922	80	16	2
7	520	80	16	1
8	1870	540	16	1
9	1775	435	16	1
10	1775	435	16	1
11	905	400	16	1
12	905	80	16	1
13	519	380	16	4
14	1805	934	2,5	1
15	1805	700	2,5	1
16	1780	492	16	1
17	1780	492	16	1

W przypadku reklamacji proszę podać numer pakowacza znajdujący się na kartonie.

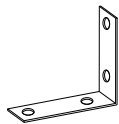

I - 2 St.

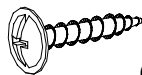

Q - 4 St.
4x25 mm



R - 1 St.

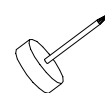

P - 8 St.

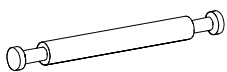

F - 6 St.



B2 - 6 St.

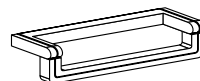

U - 2 St.

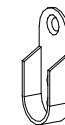

Y - 2 St.

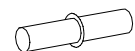

S - 20 St.

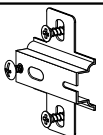

C - 8 St.

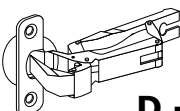

D - 8 St.

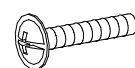

N - 4 St.
4x25 mm

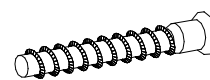

A - 11 St.

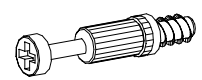

K - 13 St.

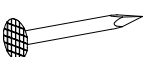

E - 100 St.



B1 - 26 St.



G - 50 St.
3,5x16 mm

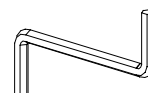

Z - 1 St.



L - 25 St.

I

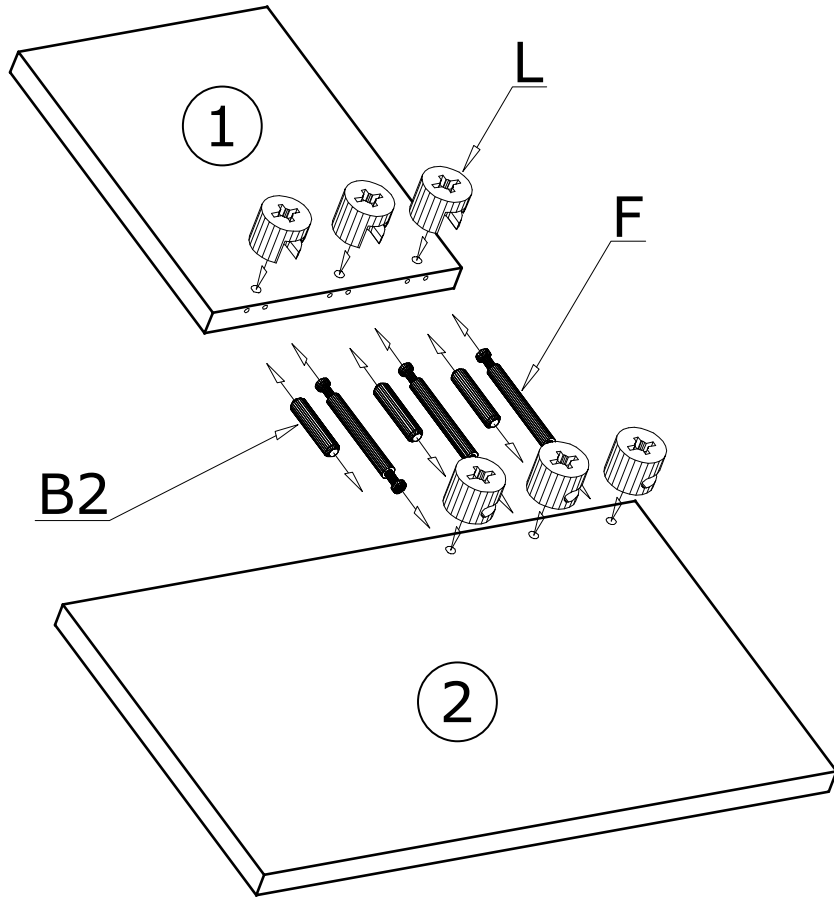

II

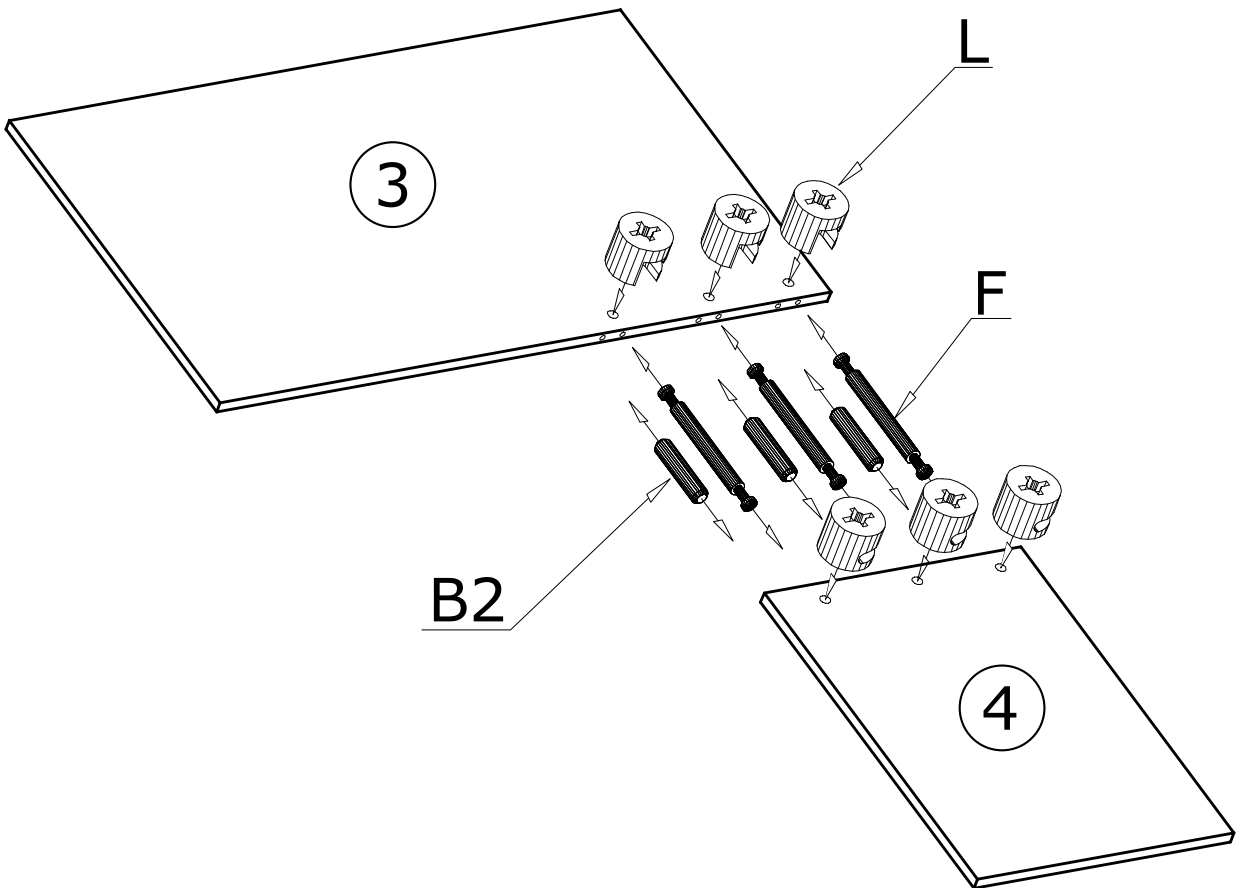

III

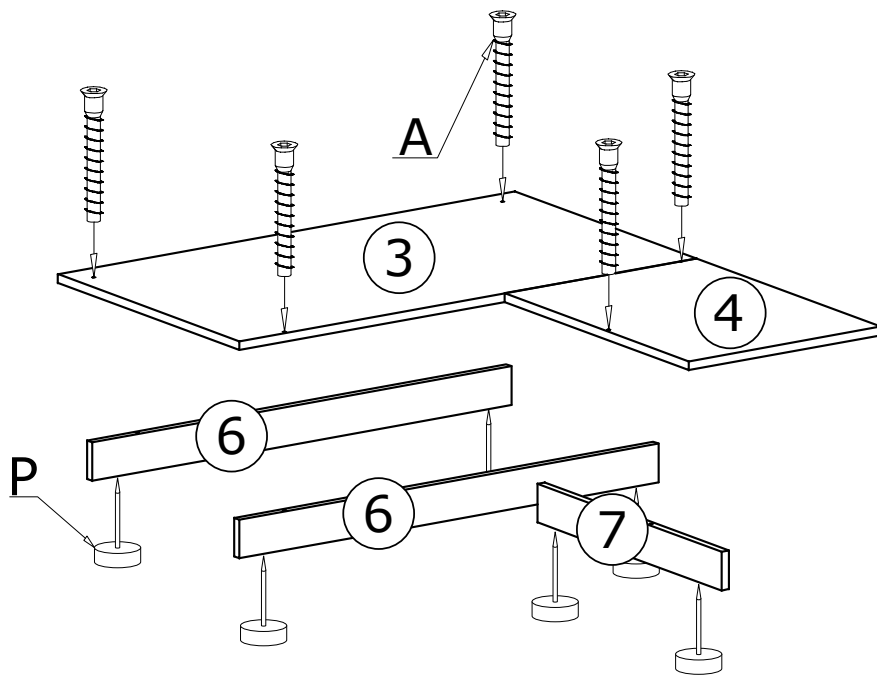

IV

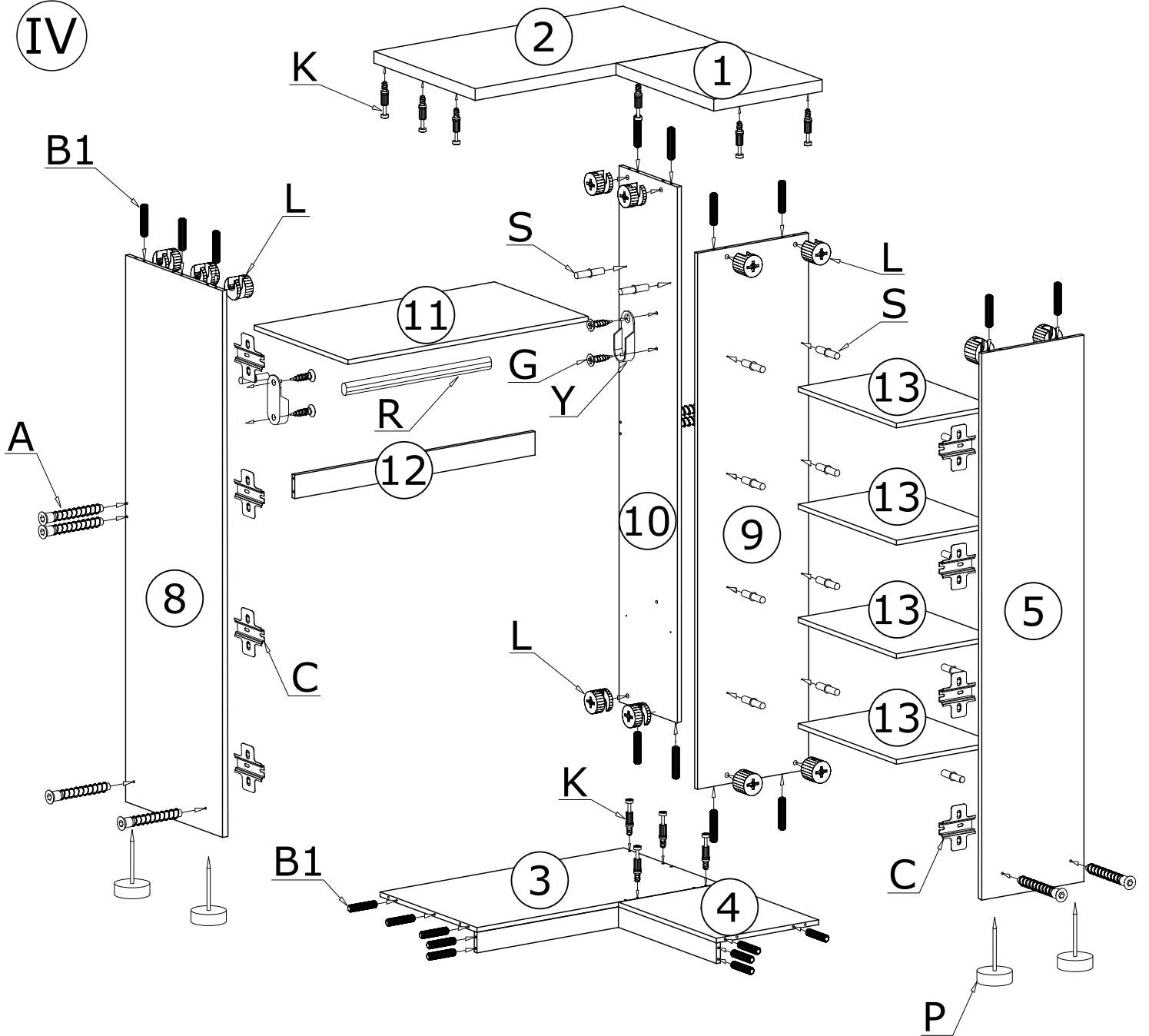

V

100X 

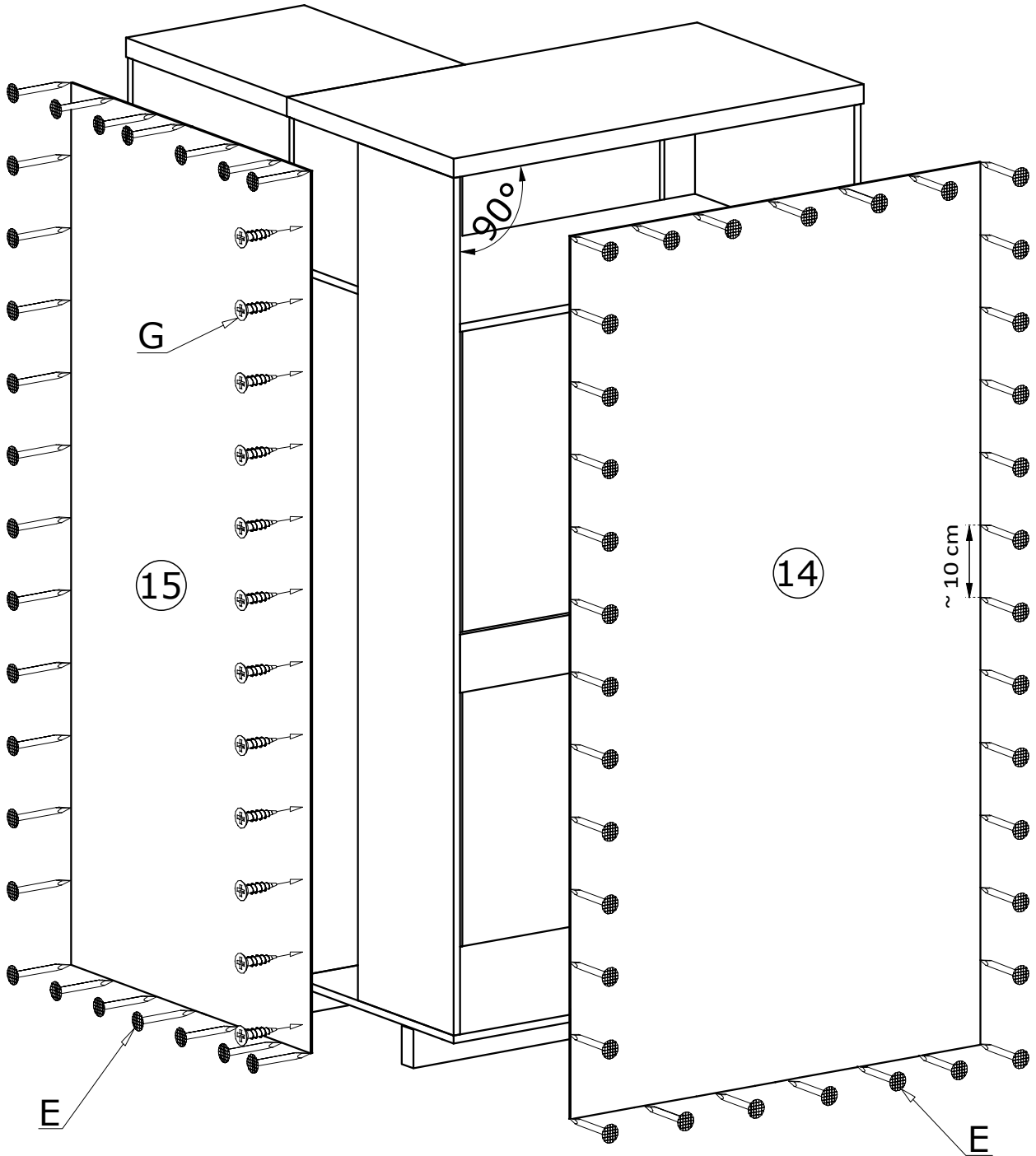

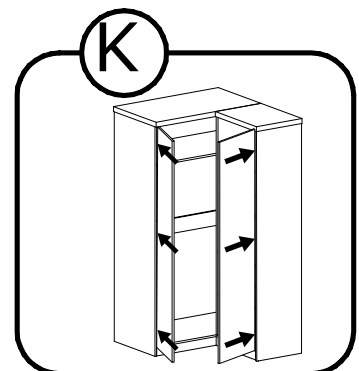
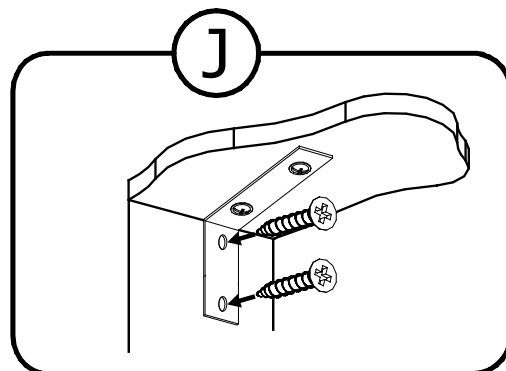
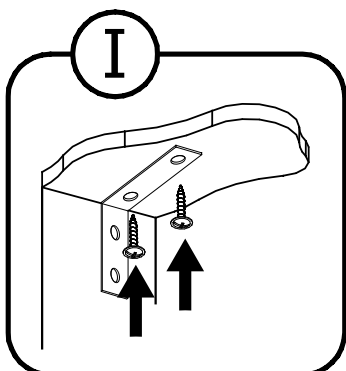
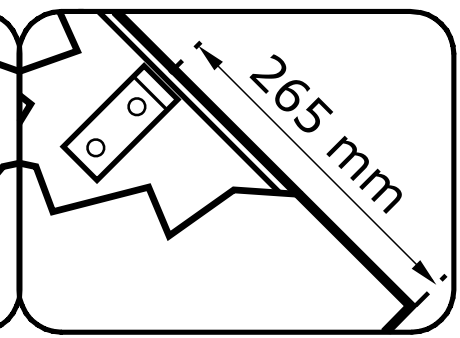
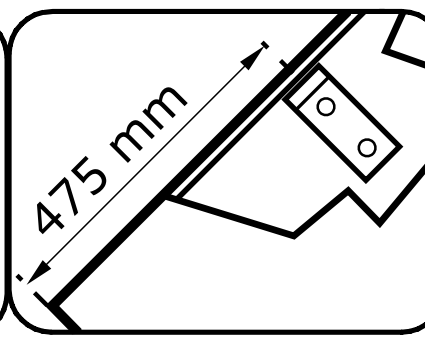
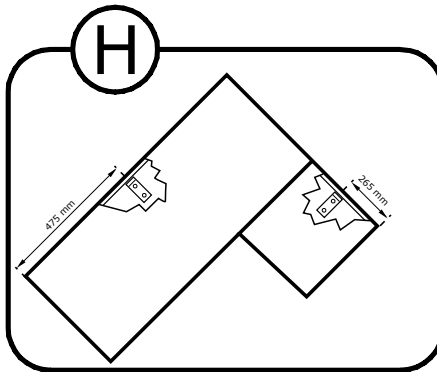
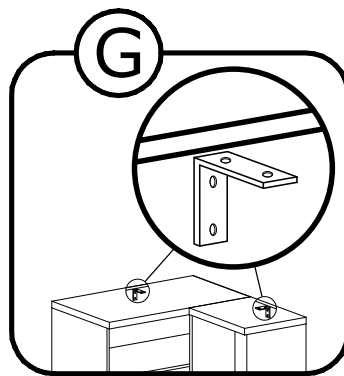
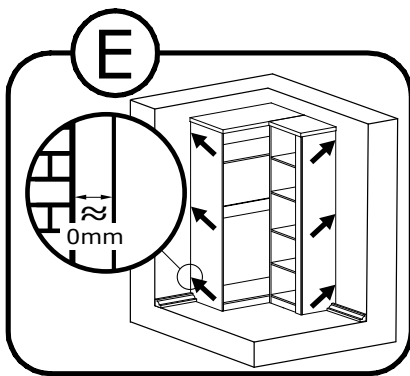
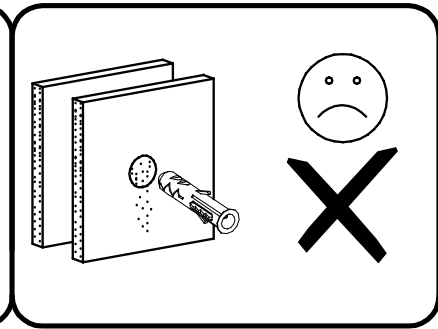
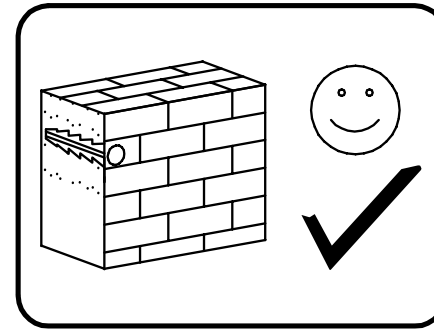
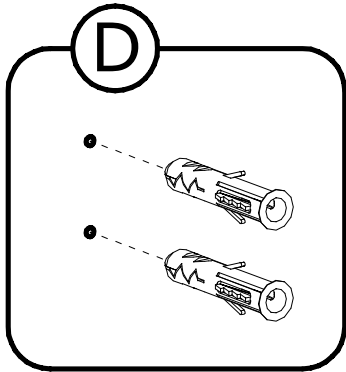
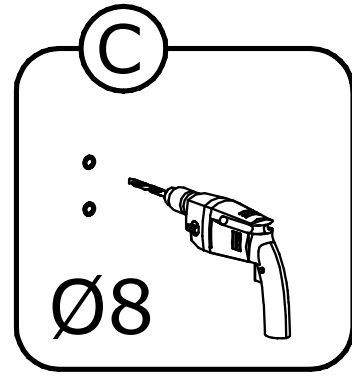
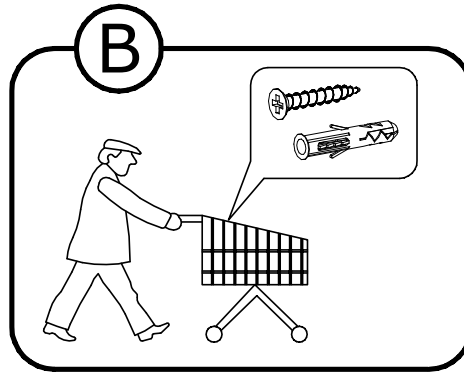
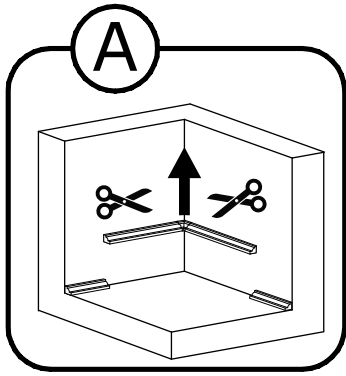

VI

