

DOUGLAS 21

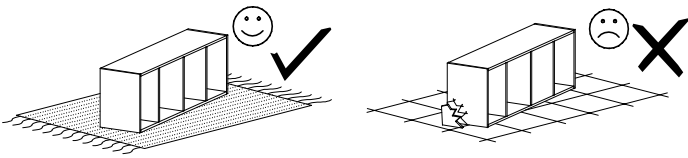

Narzędzia potrzebne do montażu

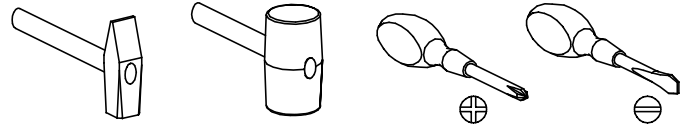

UWAGA !!!

MONTOWANIE USZKODZONYCH
ELEMENTÓW POWODUJE UTRATĘ
GWARANCJI

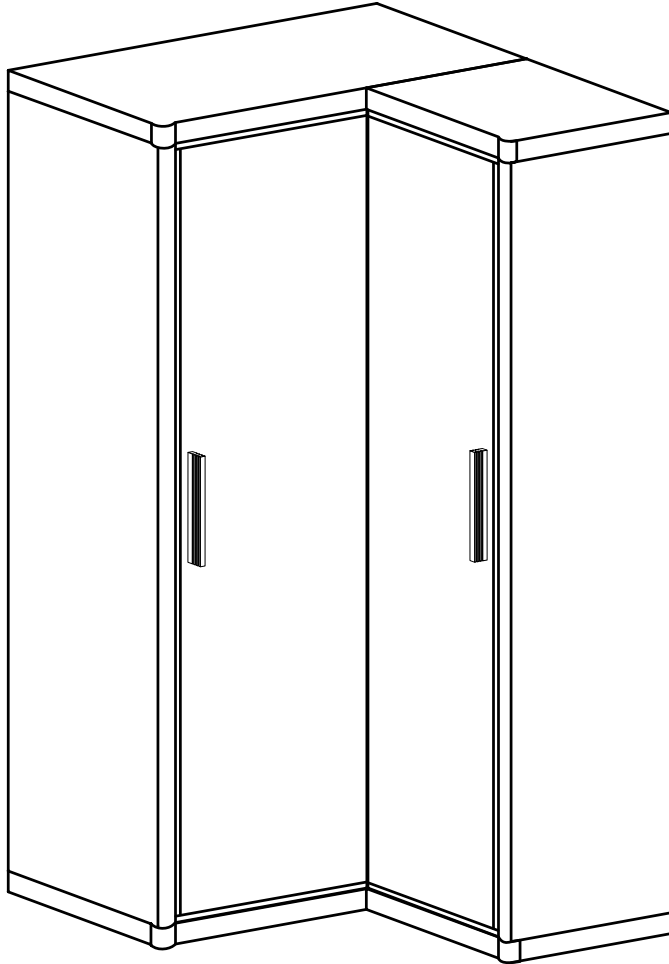

Nr	D[mm]	S[mm]	G[mm]	Ilość
1	553	450	48	1
2	1000	590	48	1
3	1000	590	48	1
4	553	450	48	1
5	1810	423	16	1
6	1810	562	16	1
7	1810	100	32	1
8	1810	100	32	1
9	1810	435	16	1
10	1810	400	16	1
11	966	400	16	1
12	966	80	16	1
13	548	380	16	4
14	1835	990	2,5	1
15	1835	840	2,5	1
16	1780	463	16	1
17	1780	463	16	1

W przypadku reklamacji proszę podać numer pakowacza znajdujący się na kartonie.

Y - 1 St.	Q - 2 St. 3,5x16 mm	X1 - 38 St.	X2 - 2 St.	
A - 7 St.	R - 14 St. 3,9x25 mm	M - 1 St.	T - 2 St.	F - 6 St.
S - 6 St.	N - 4 St. 4x27 mm	U - 2 St.	G - 37 St. 3,5x16 mm	L - 38 St.
W - 2 St.	E - 100 St.	C - 8 St.	D - 4 St.	Z - 1 St.
P - 20 St.	B - 20 St.	K - 26 St.	Z - 1 St.	J - 4 St.

I

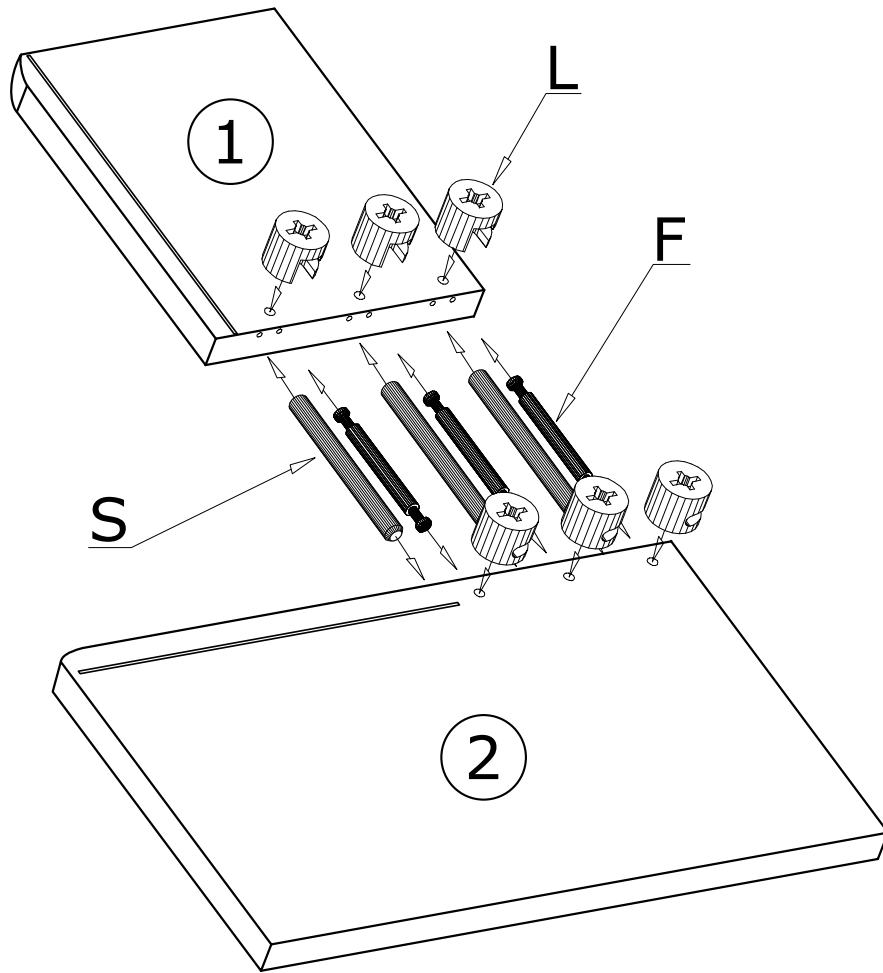

II

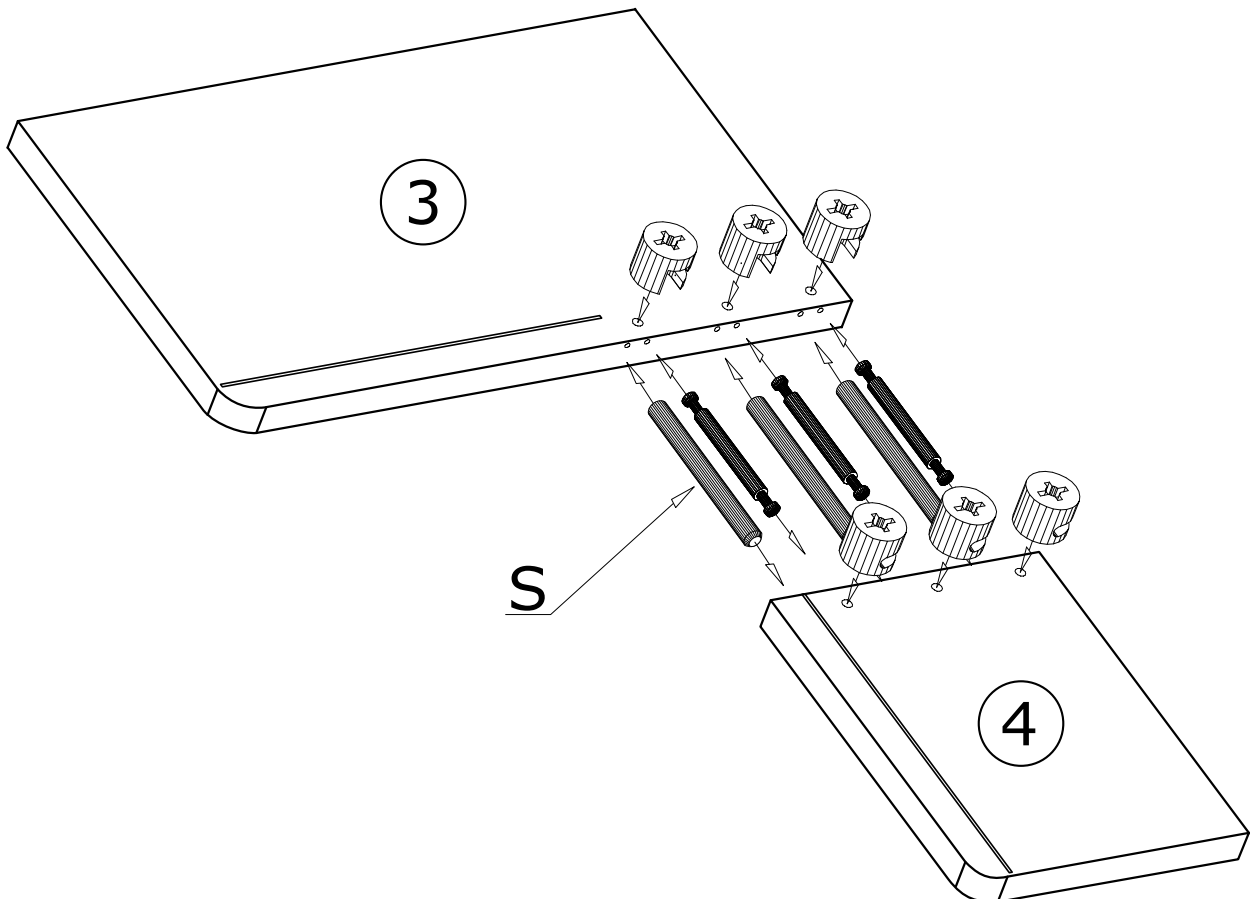

III

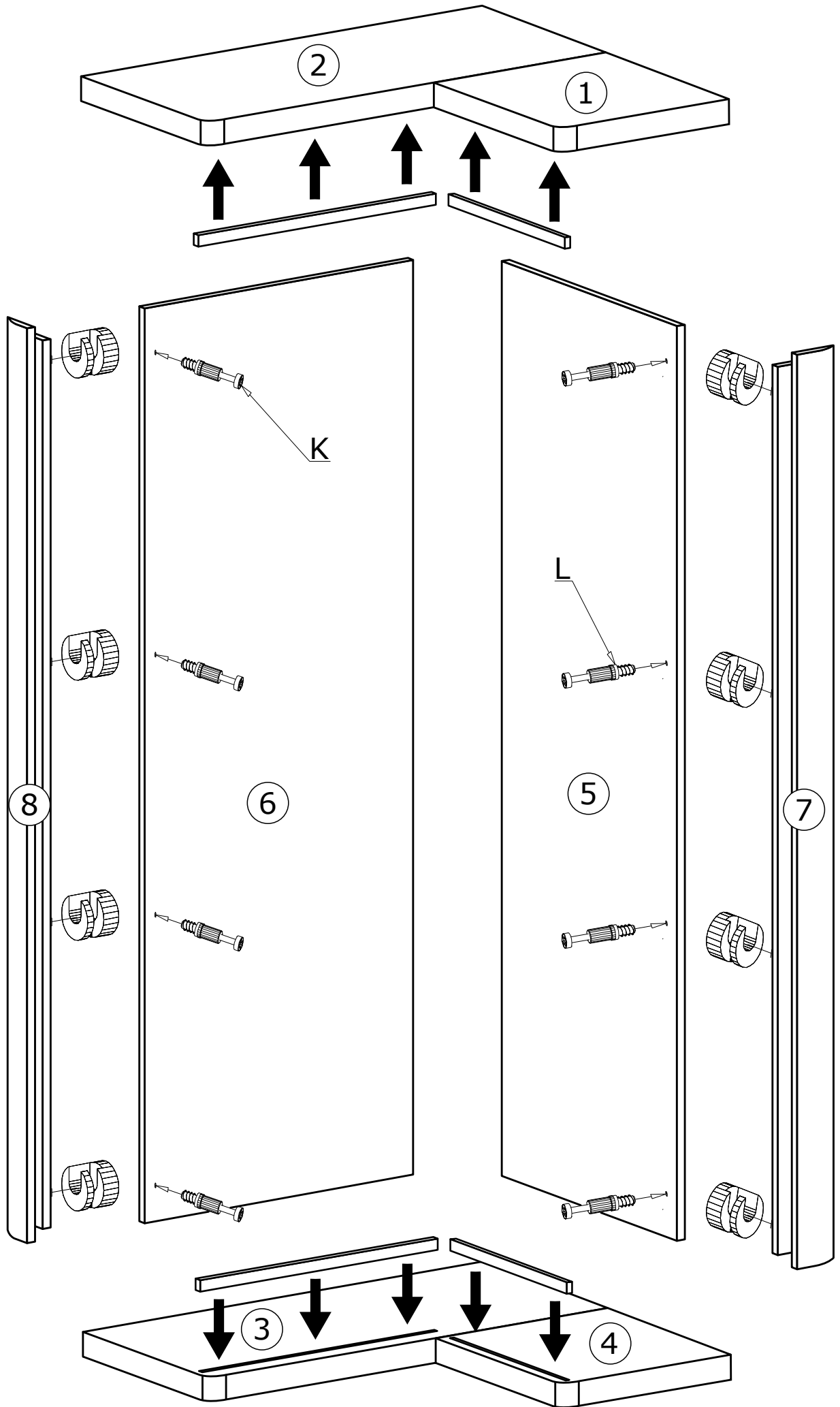

IV

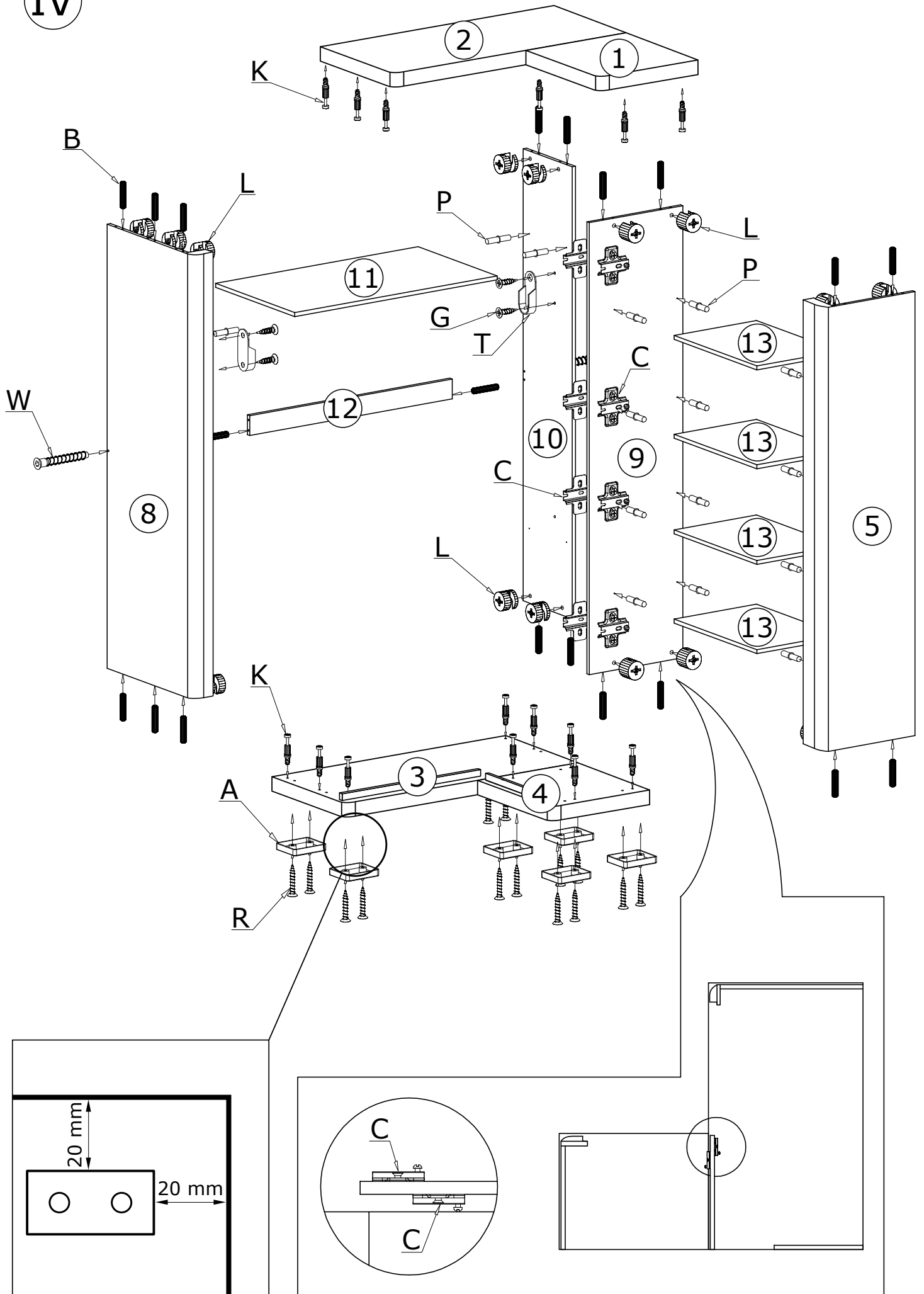

V

100X 

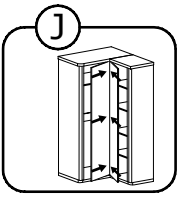
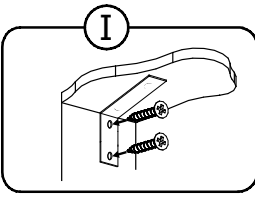
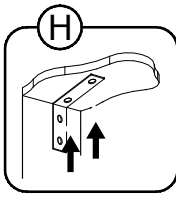
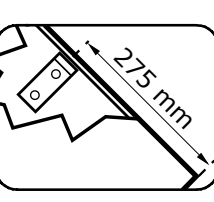
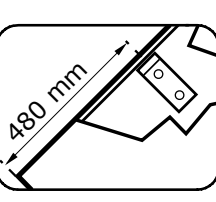
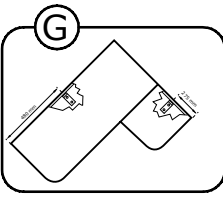
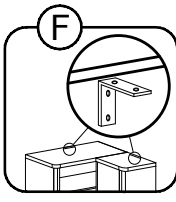
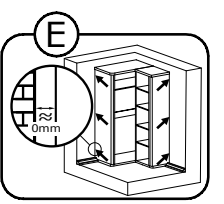
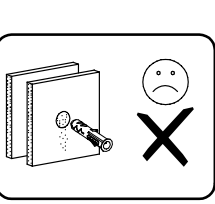
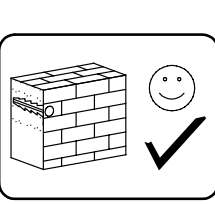
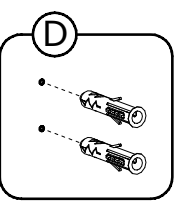
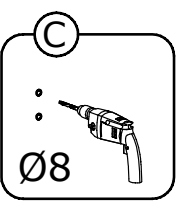
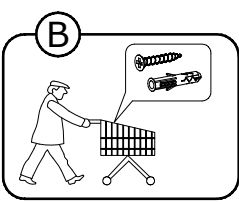
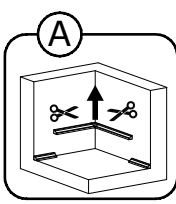
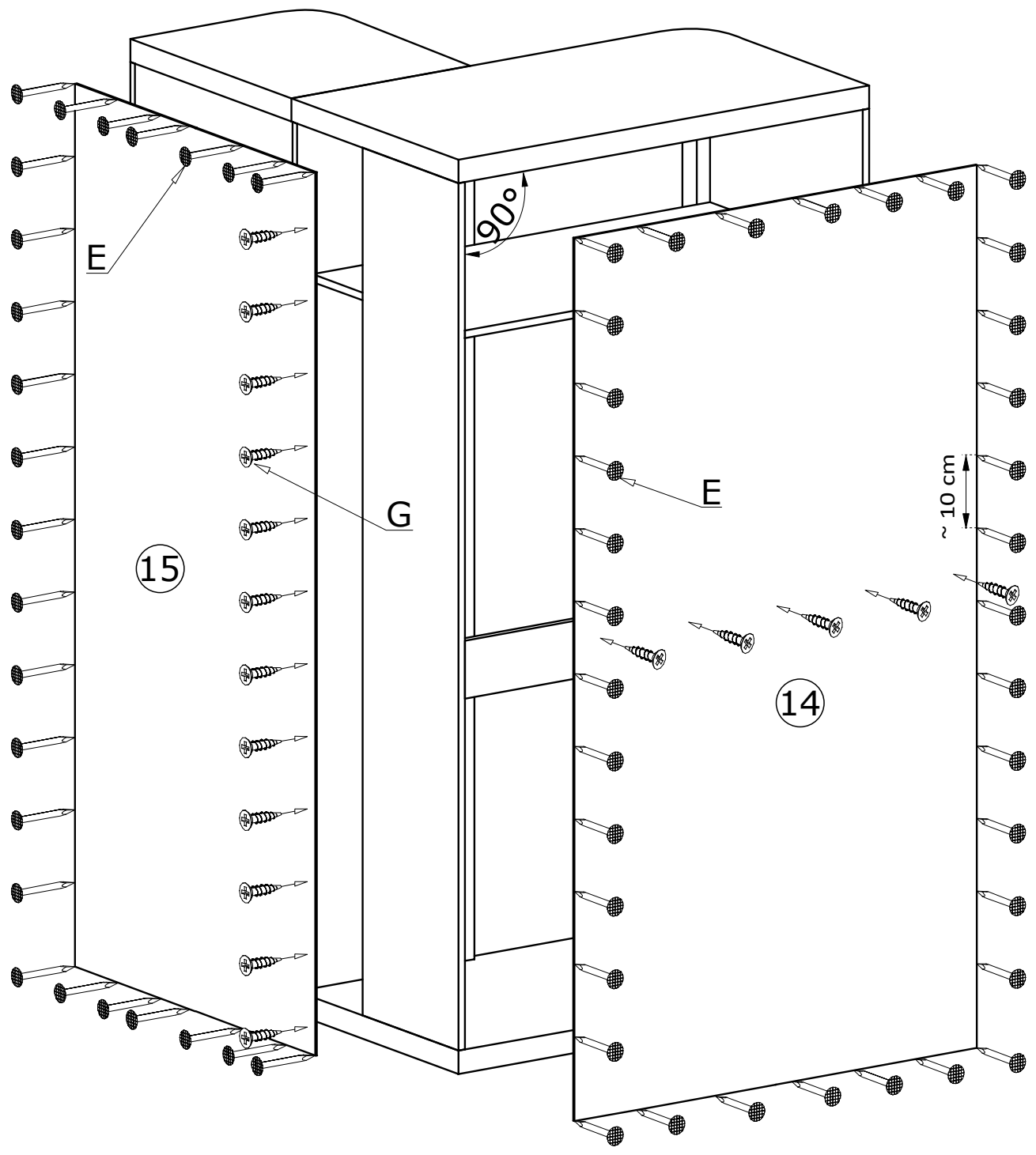

VI

