

DOUGLAS 19

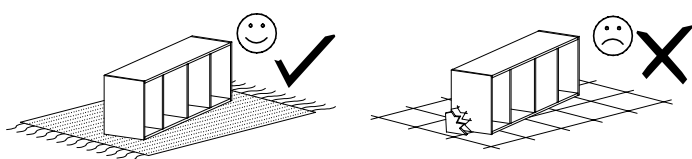

Narzędzia potrzebne do montażu

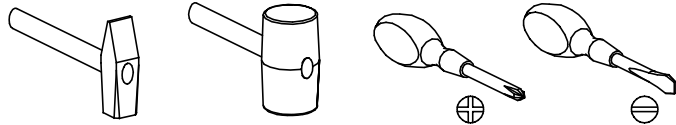

LEWA

PRAWA

UWAGA !!!

MONTOWANIE USZKODZONYCH
ELEMENTÓW POWODUJE UTRATĘ
GWARANCJI

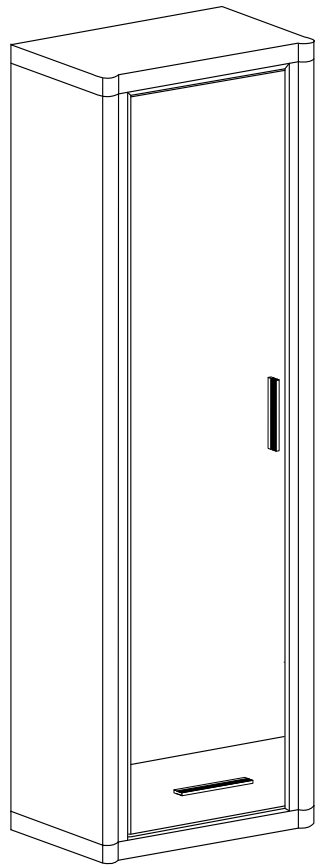

LUB

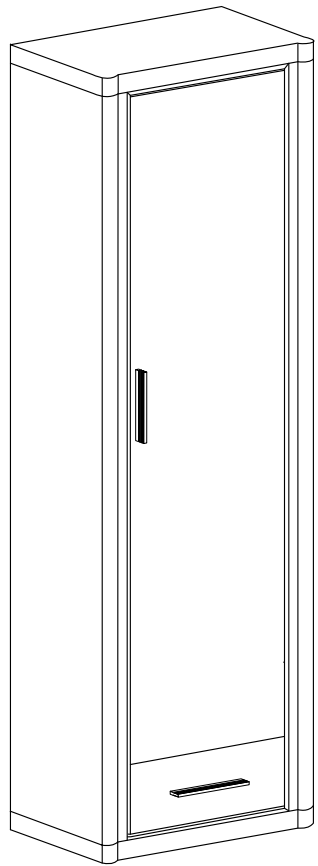

Nr	D[mm]	S[mm]	G[mm]	Ilość
1	590	580	48	1
2	590	580	48	1
3	540	25	16	2
4	1810	563	16	1
5	1810	563	16	1
6	1810	100	32	1
7	1810	100	32	1
8	545	200	16	1
9	545	200	16	1
10	545	545	16	1
11	1835	570	2,5	1
12	380	190	16	1
13	500	150	16	1
14	500	150	16	1
15	305	150	16	1
16	505	334	2,5	1
17	1587	380	16	1
18	545	530	16	3

W przypadku reklamacji proszę podać numer pakowacza znajdujący się na kartonie.

O - 1 St.	Y - 1 St.	X1 - 22 St.	X2 - 4 St.	
I - 2 St. 3,5x16 mm	A - 4 St.	M - 12 St. 3,9x25 mm		
H - 2 St.	N - 4 St. 4x27 mm	C - 3 St.	T - 1 Kpl.	F - 4 St.
U - 2 St.	G - 10 St. 3,5x16 mm	D - 3 St.	W - 4 St.	L - 22 St.
E - 50 St.	B - 24 St.	K - 22 St.	Z - 1 St.	J - 4 St. 5x13 mm

I

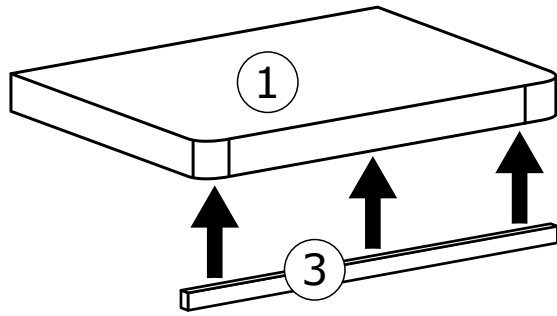

LEWA

PRAWA

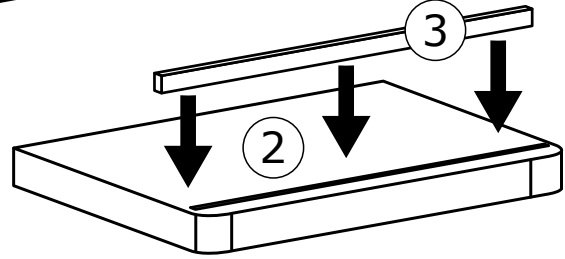
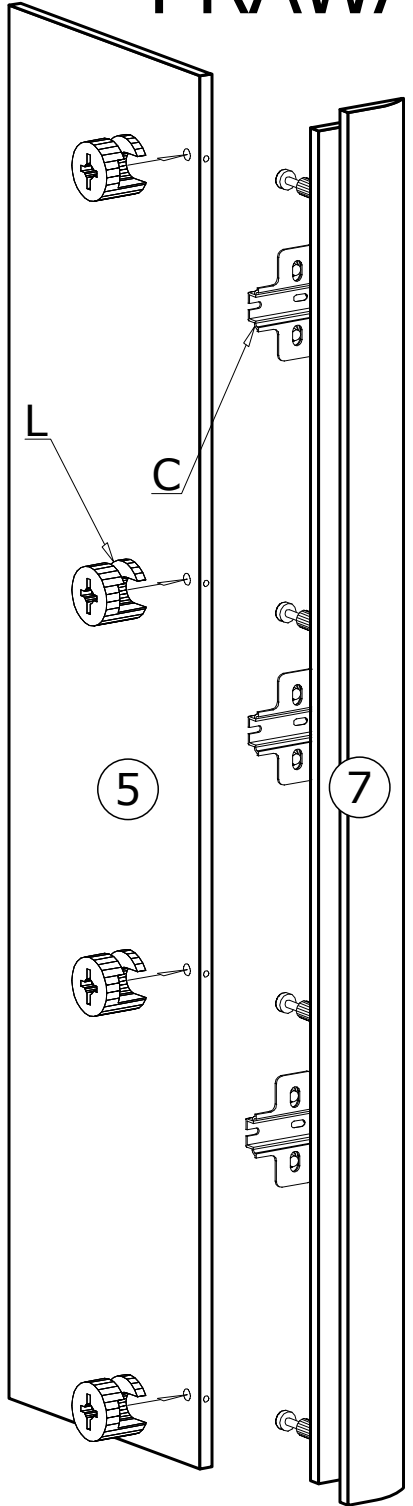
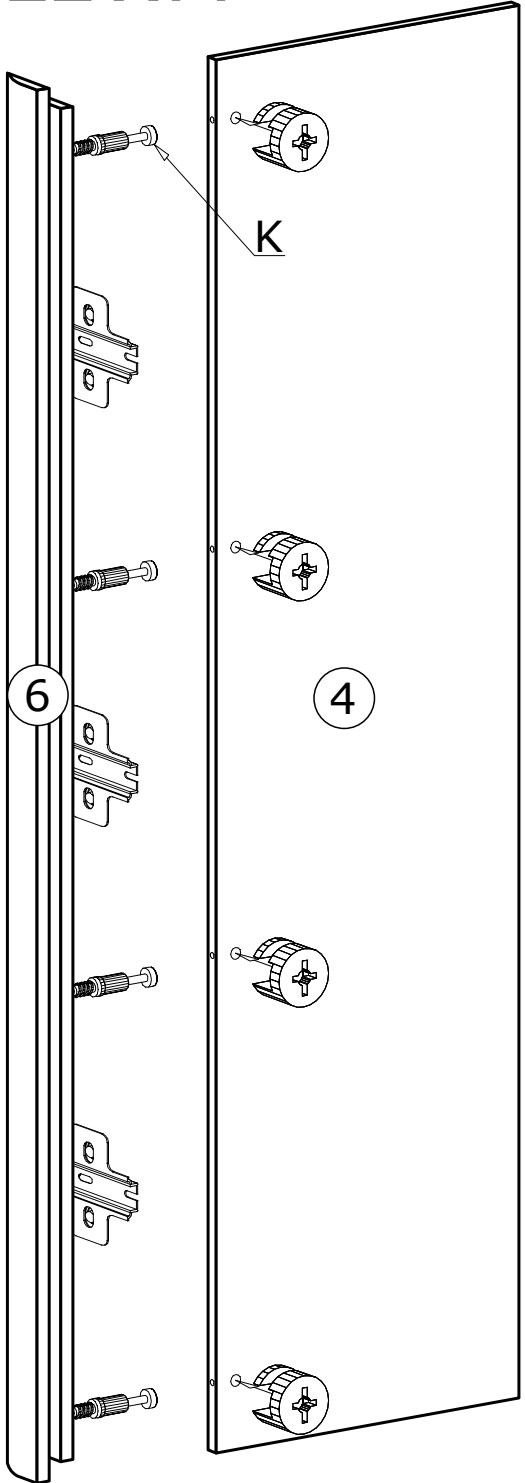

III

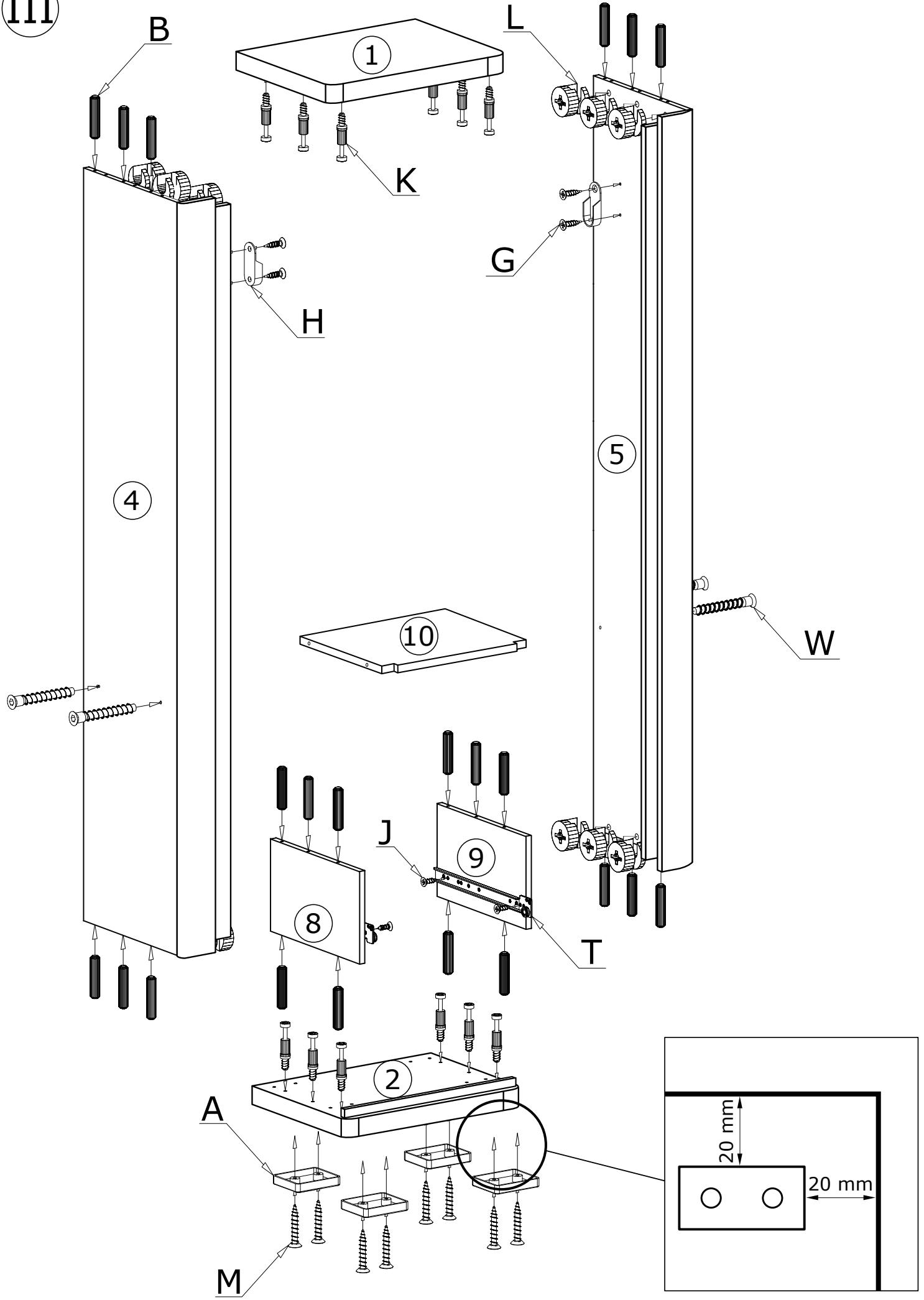

III

50X 

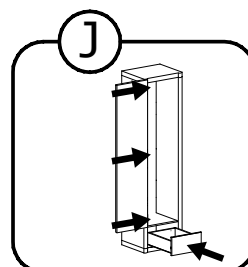
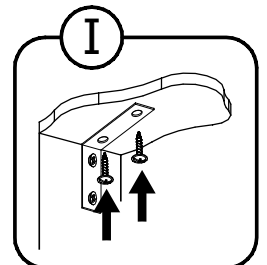
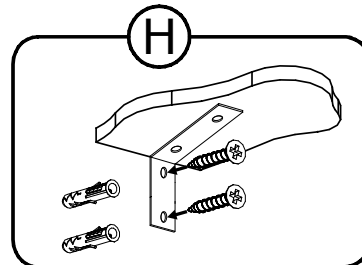
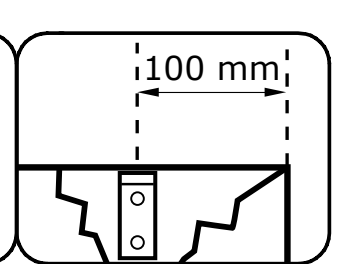
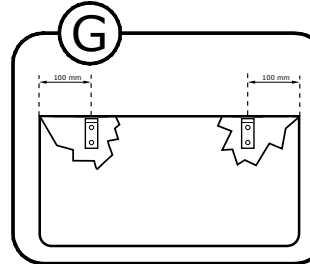
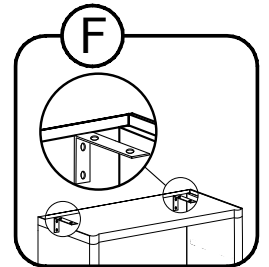
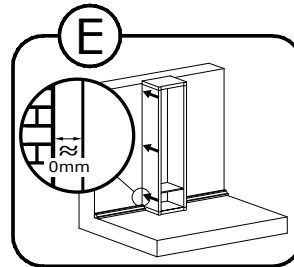
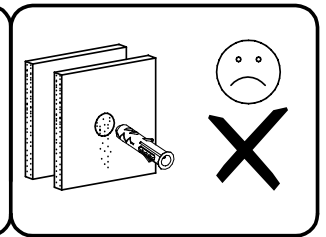
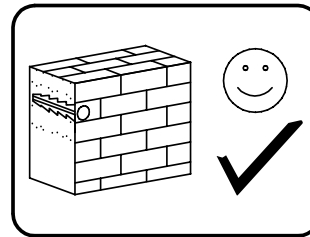
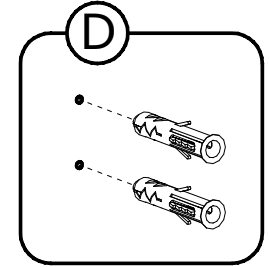
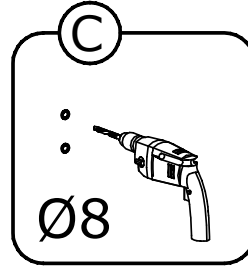
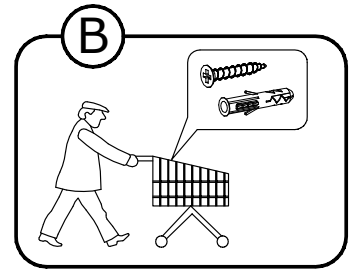
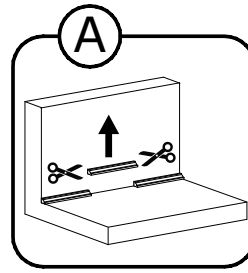
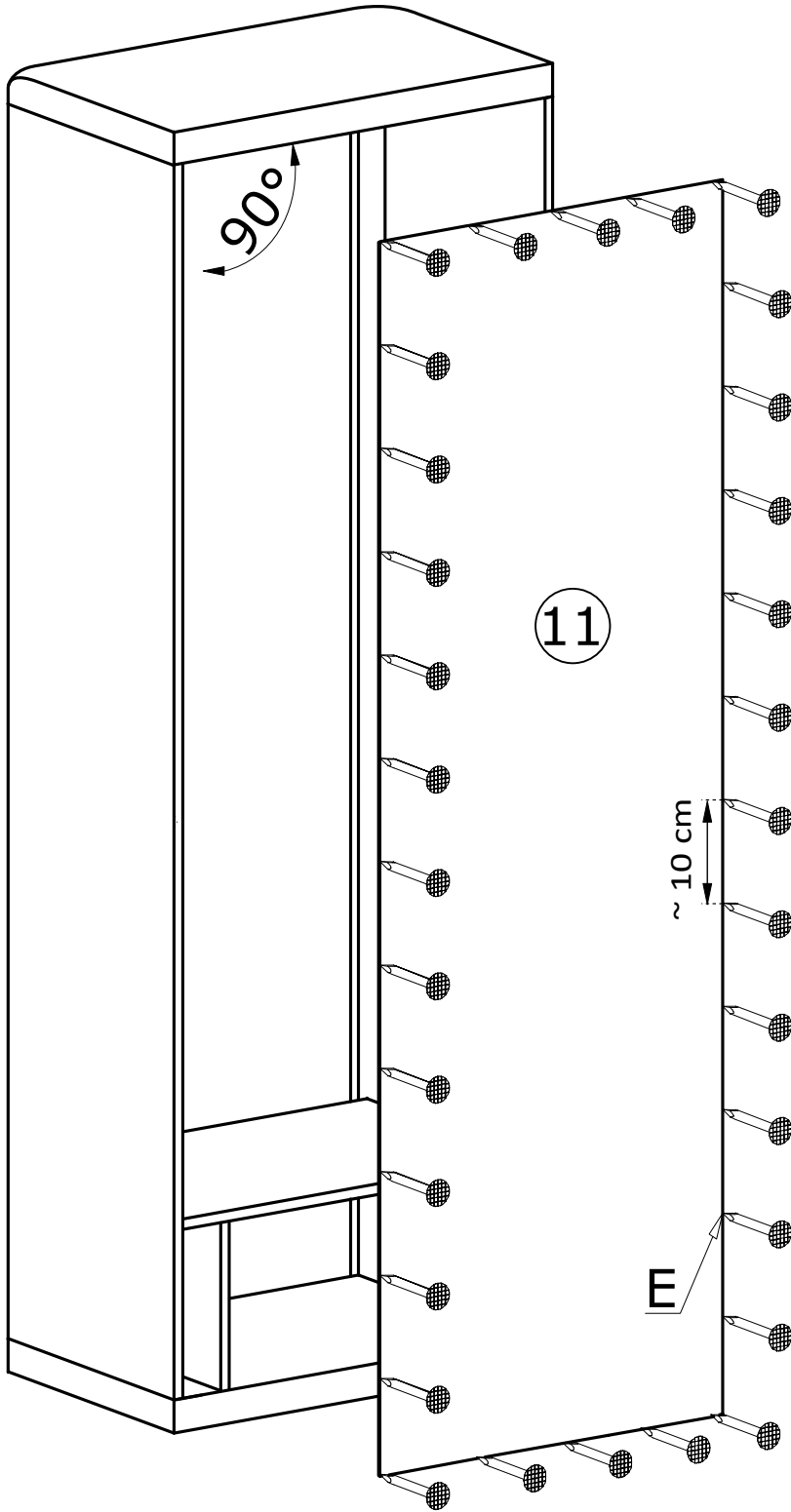

IV

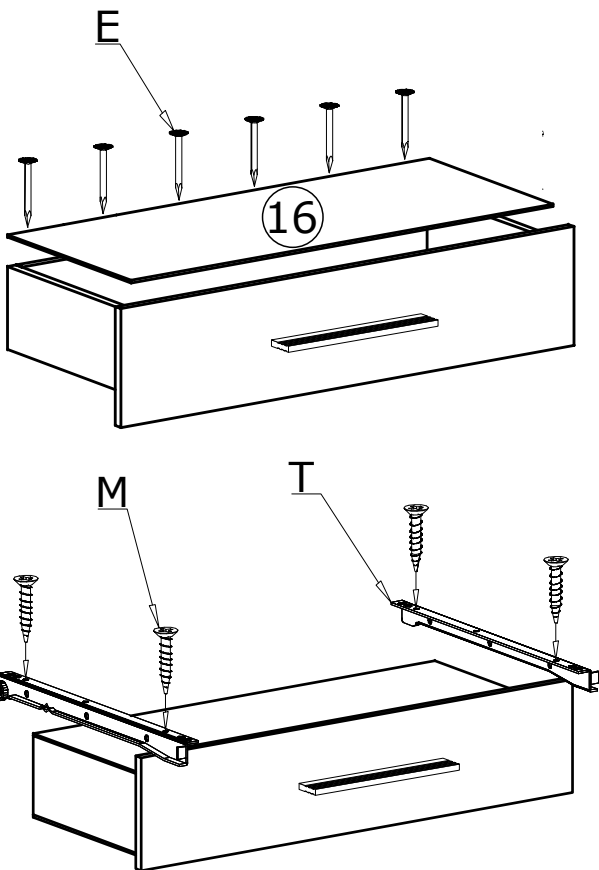
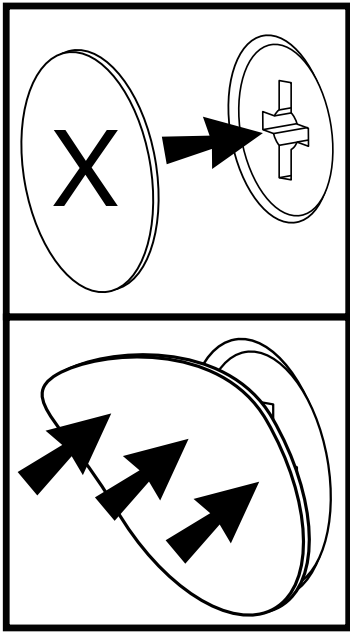
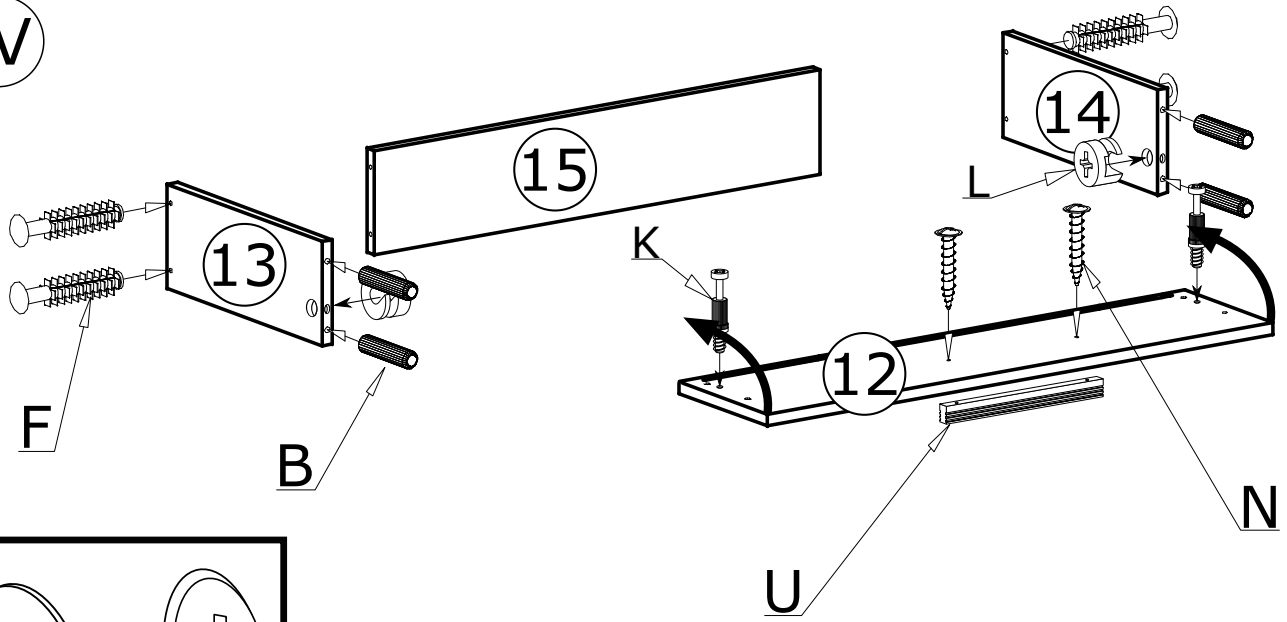

V

PRAWA

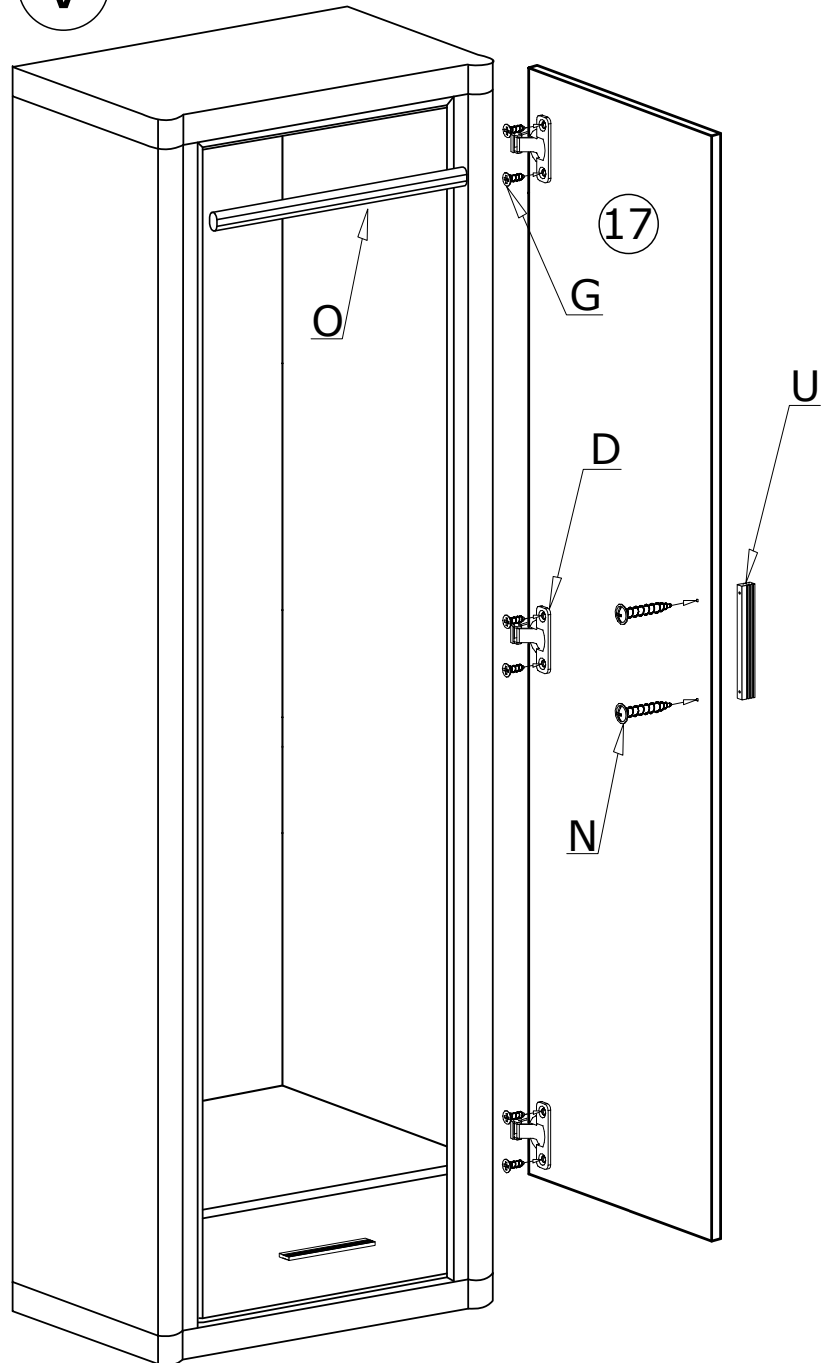

V

LEWA

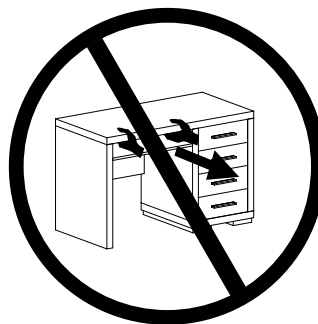
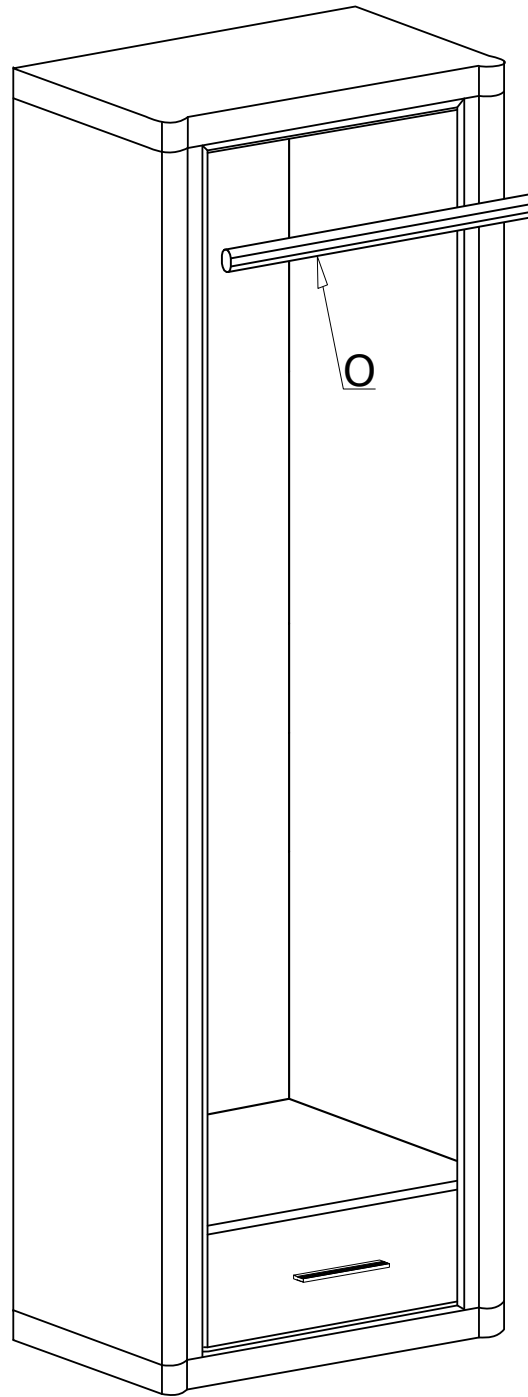
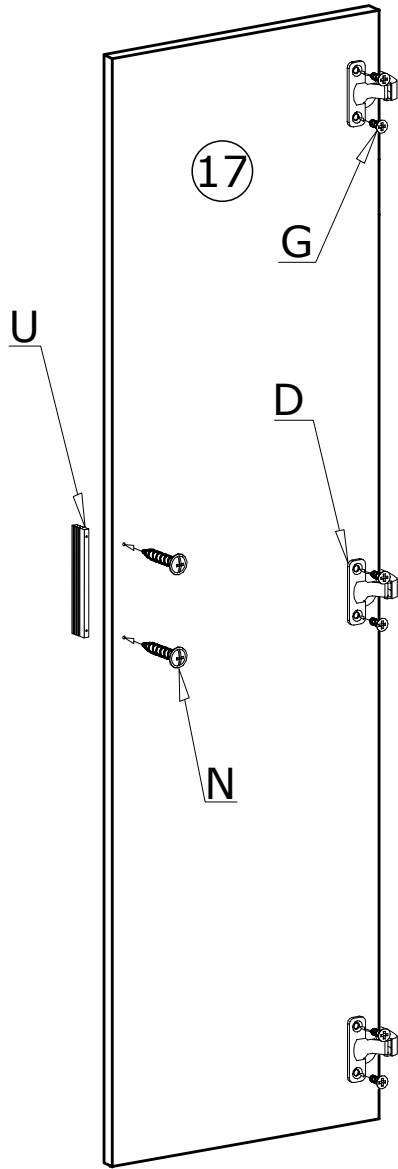

VI

OPCJONALNIE

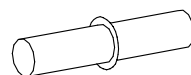
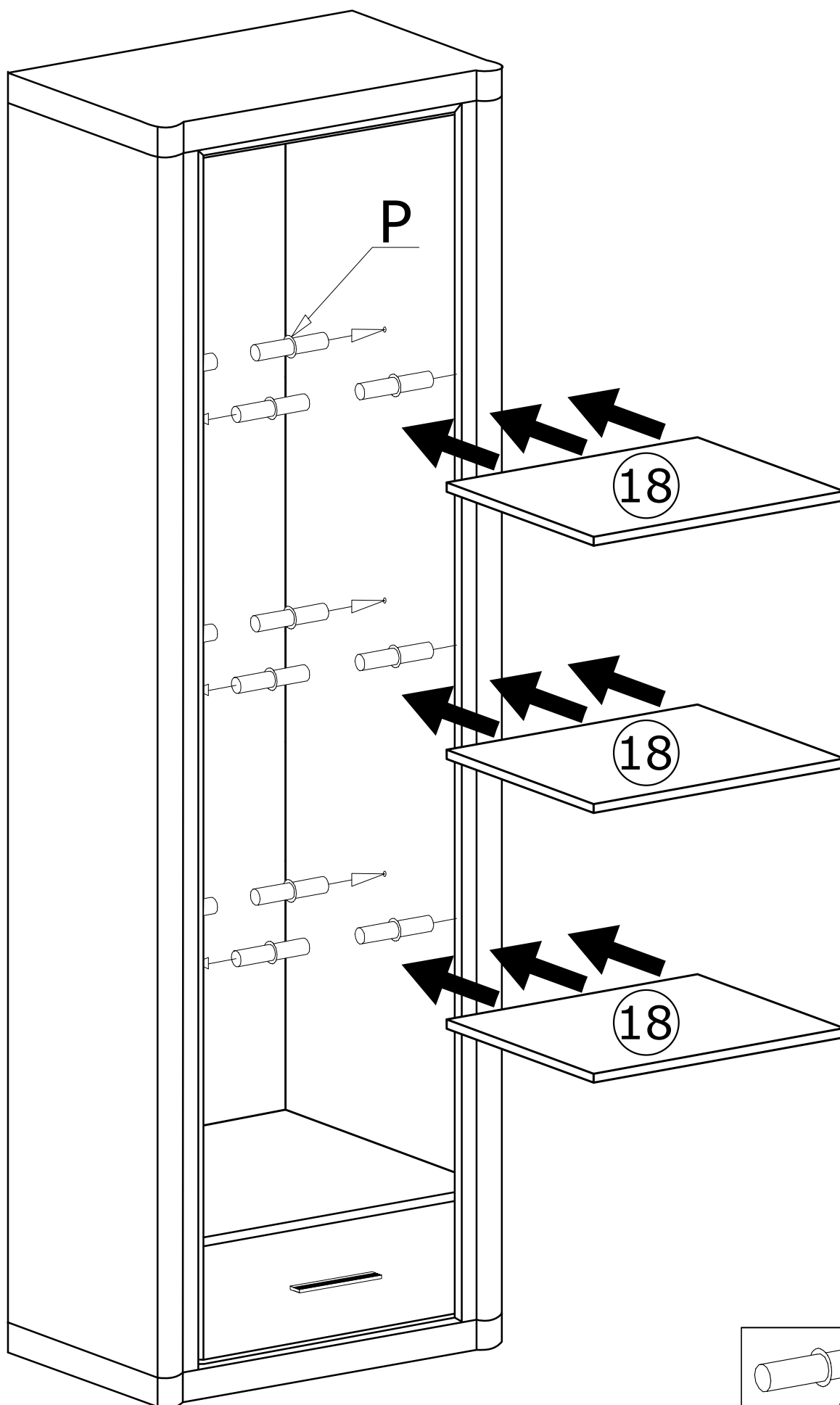

P - 12 St.