

DOUGLAS 16

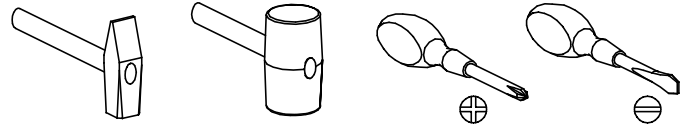

Narzędzia potrzebne do montażu



LEWA

PRAWA

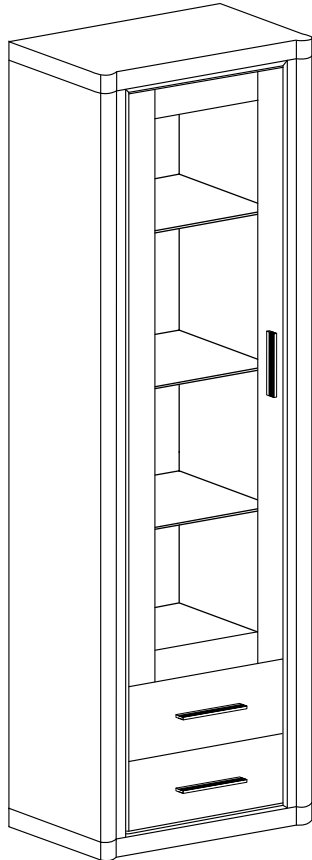

LUB

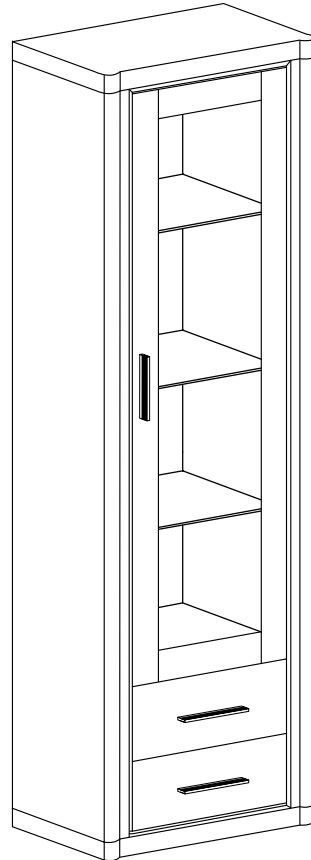

UWAGA !!!

MONTOWANIE USZKODZONYCH
ELEMENTÓW POWODUJE UTRATĘ
GWARANCJI

Nr	D[mm]	S[mm]	G[mm]	Ilość
1	580	450	48	1
2	580	450	48	1
3	540	25	16	2
4	1810	422	16	1
5	1810	422	16	1
6	1810	100	32	1
7	1810	100	32	1
8	395	405	16	1
9	395	405	16	1
10	545	405	16	1
11	1835	286	2,5	1
12	380	190	16	2
13	400	150	16	2
14	400	150	16	2
15	305	150	16	2
16	334	405	2,5	2
17	1430	380	16	1
18	542	350	4	3

W przypadku reklamacji proszę podać numer pakowacza znajdujący się na kartonie.

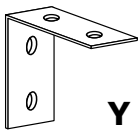

Y - 1 St.



X1 - 20 St.



X2 - 4 St.



X3 - 2 St.
Ø5 mm

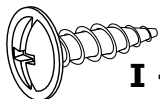

I - 2 St.
3,5x16 mm

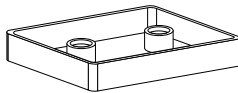

A - 4 St.

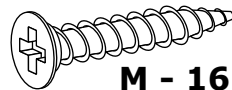

M - 16 St.
3,9x25 mm

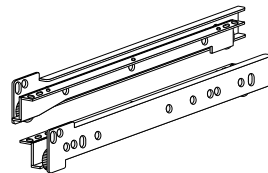

T - 2 Kpl.

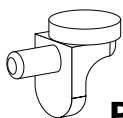

P - 12 St.

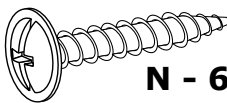

N - 6 St.
4x27 mm

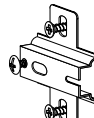

C - 3 St.

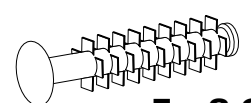

F - 8 St.

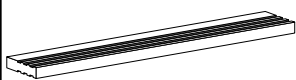

U - 3 St.

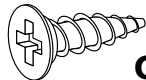

G - 6 St.
3,5x16 mm

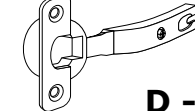

D - 3 St.

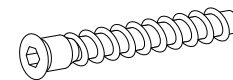

W - 4 St.



L - 20 St.

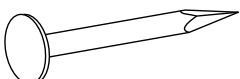

E - 50 St.

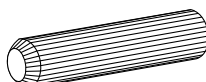

B - 24 St.

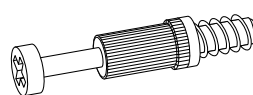

K - 20 St.

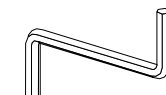

Z - 1 St.

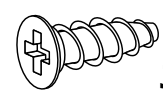

J - 8 St.
5x13 mm

I

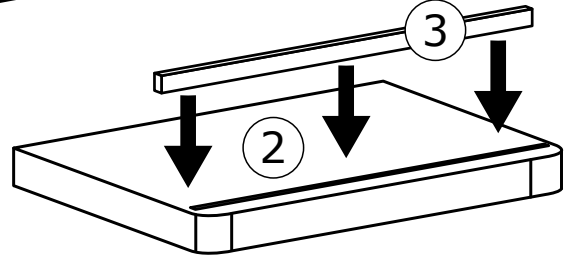
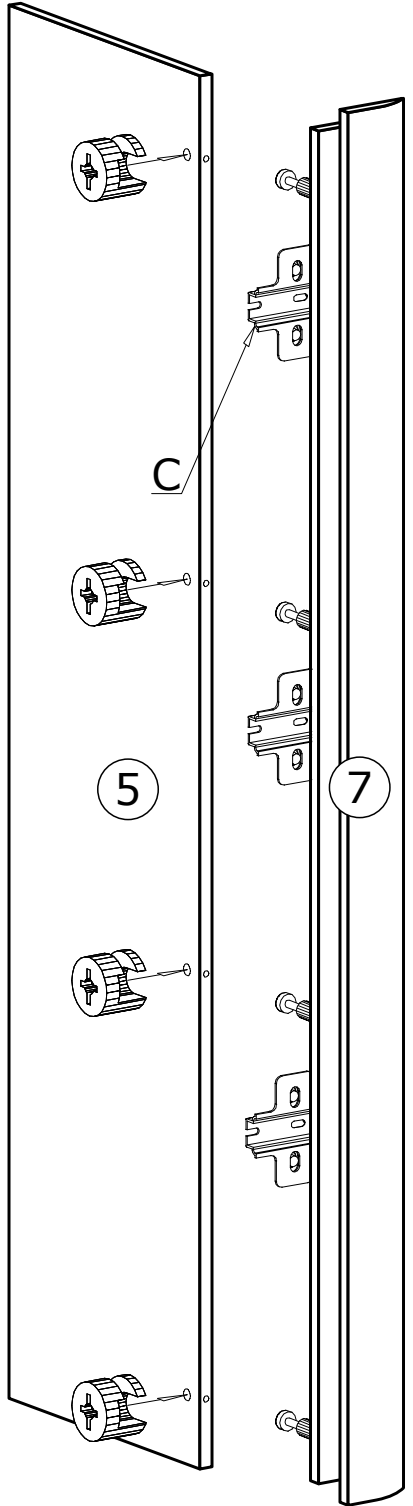
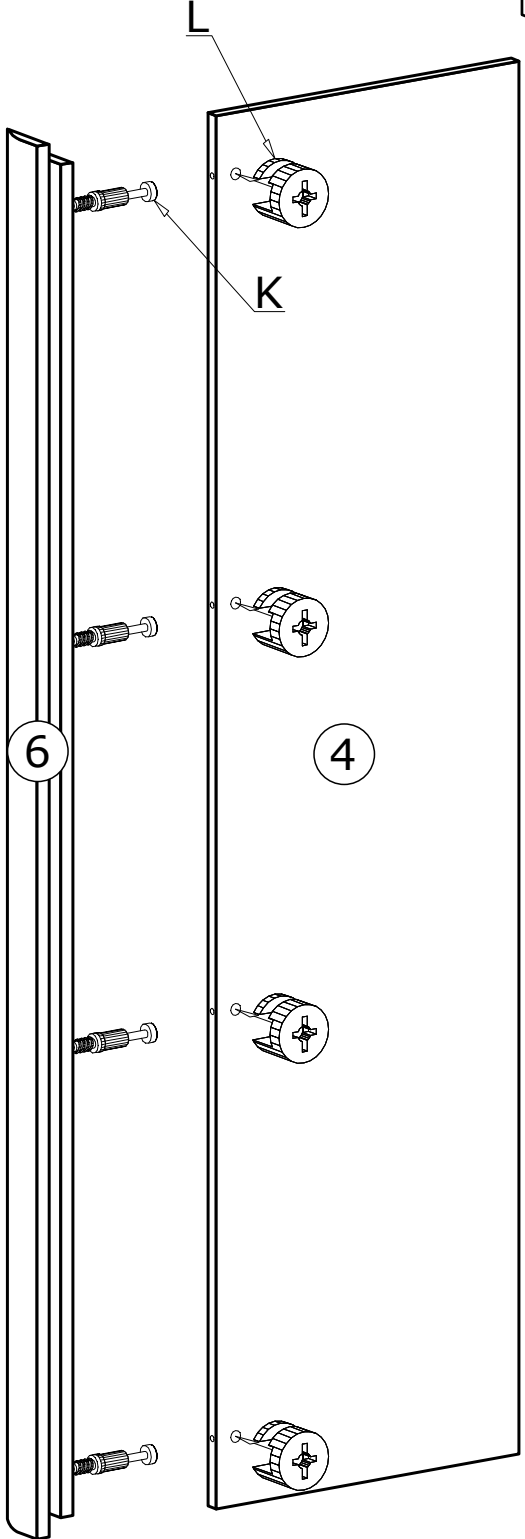
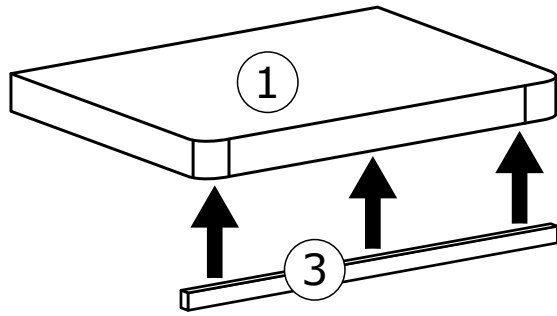

III

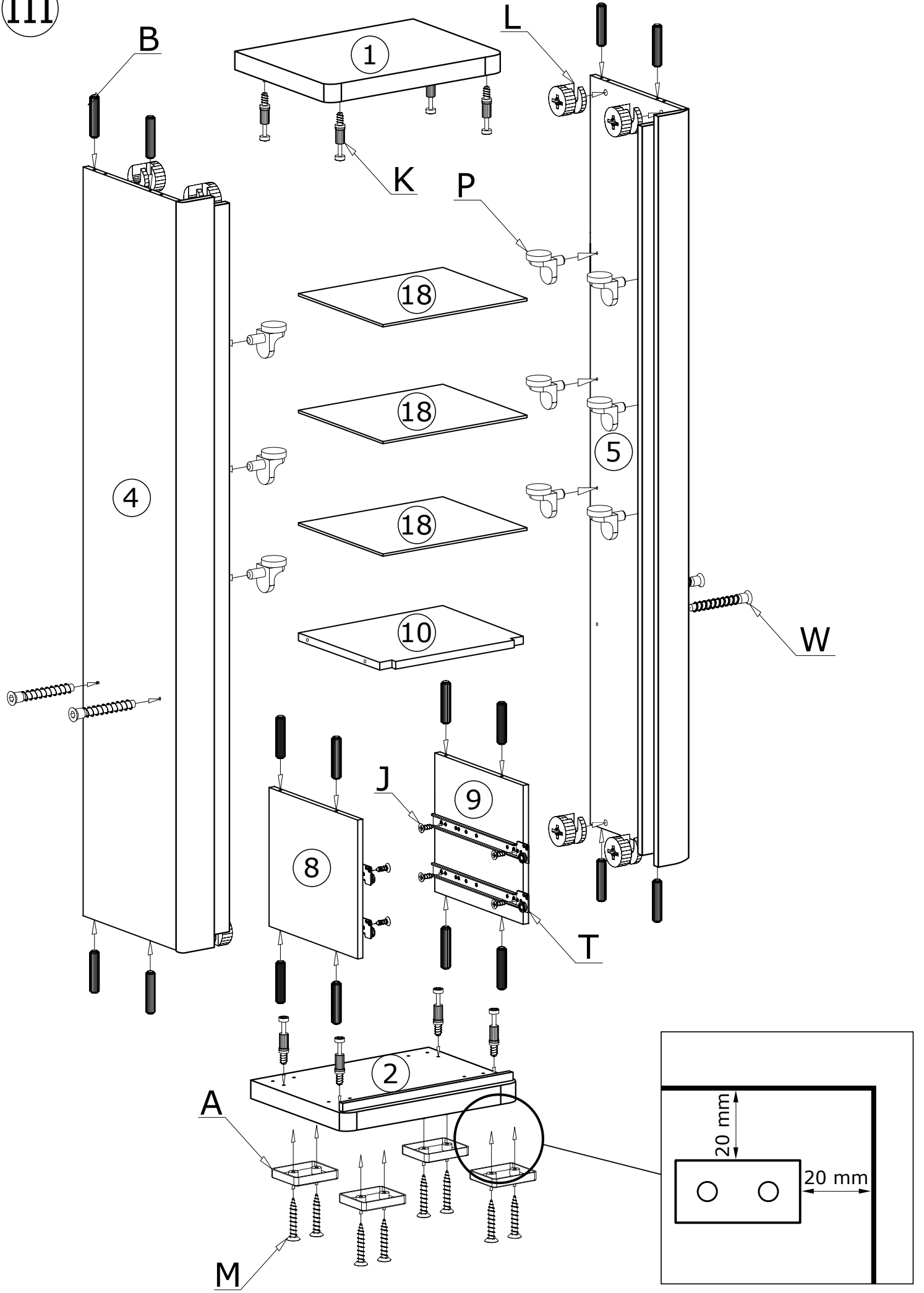

III

50X 

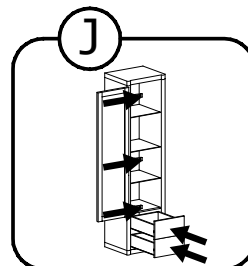
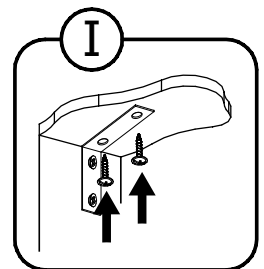
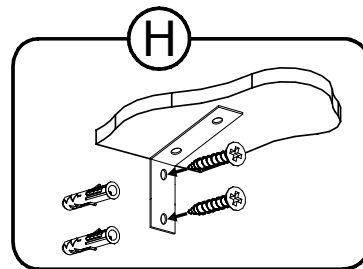
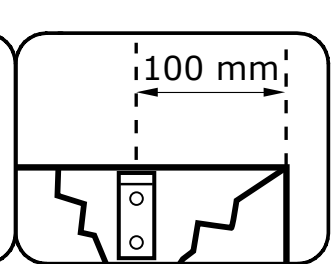
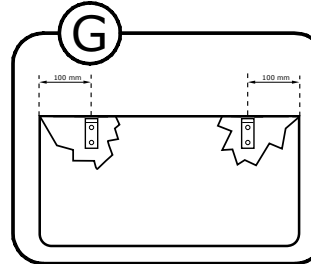
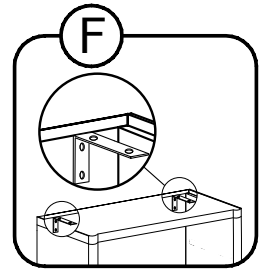
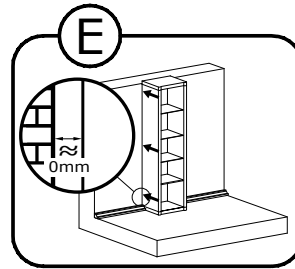
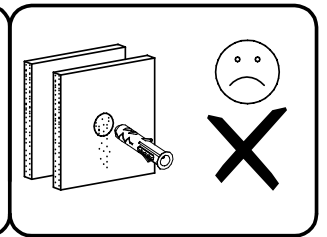
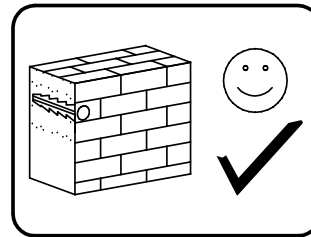
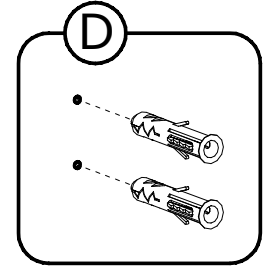
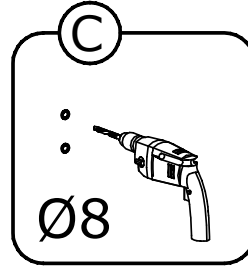
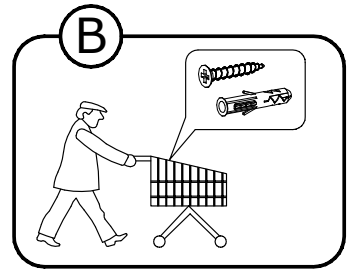
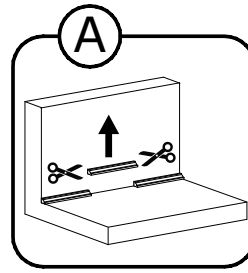
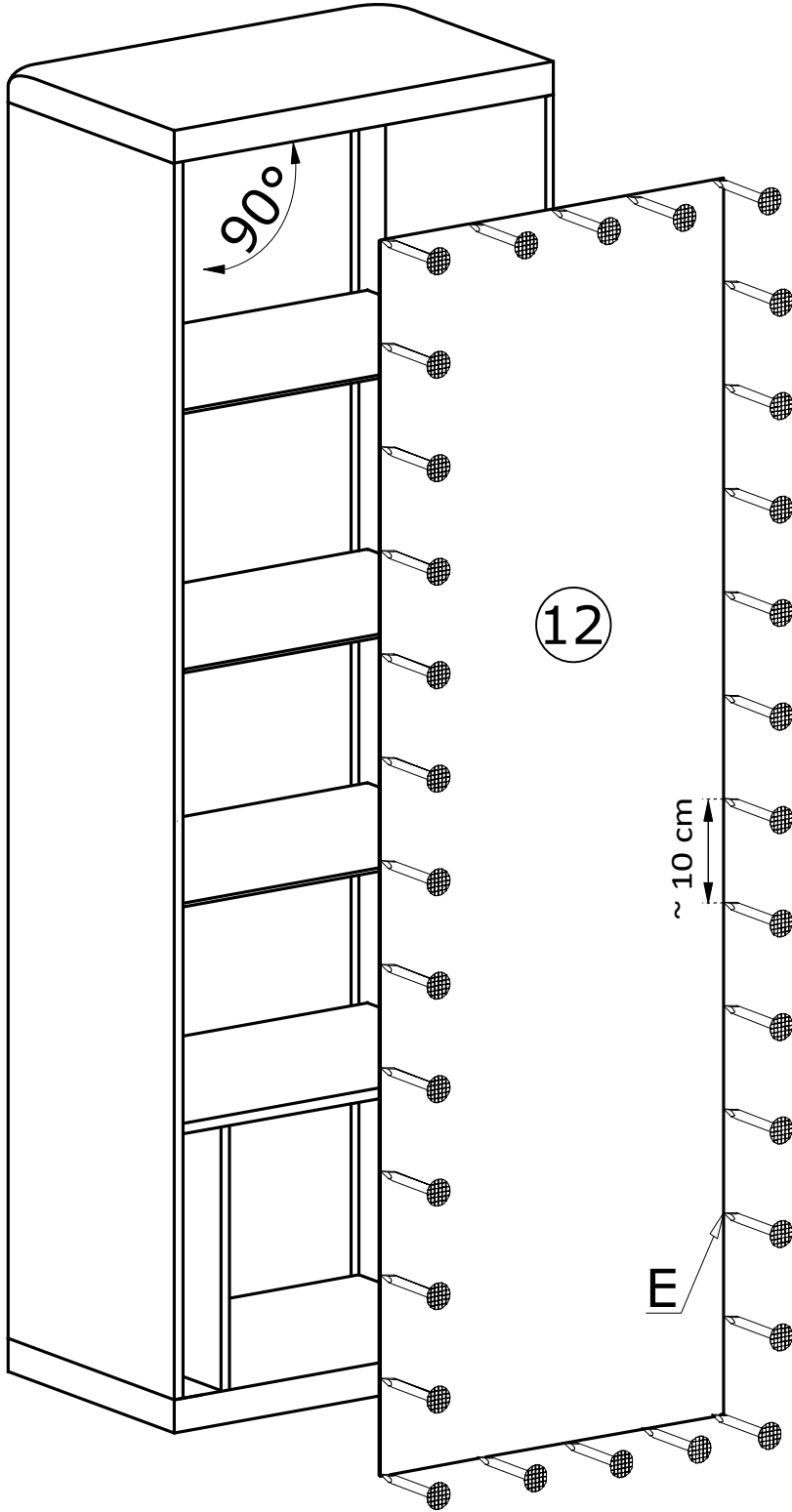

IV

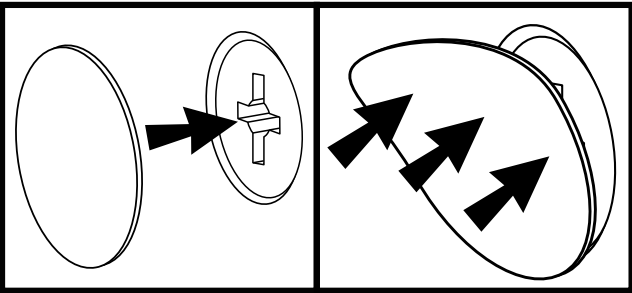
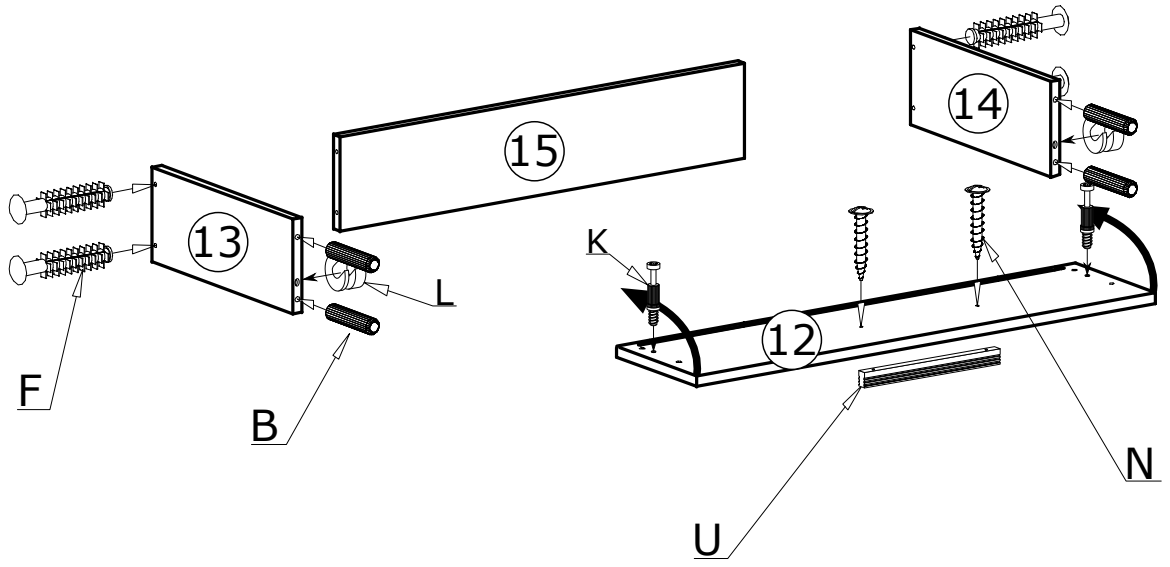

V

PRAWA

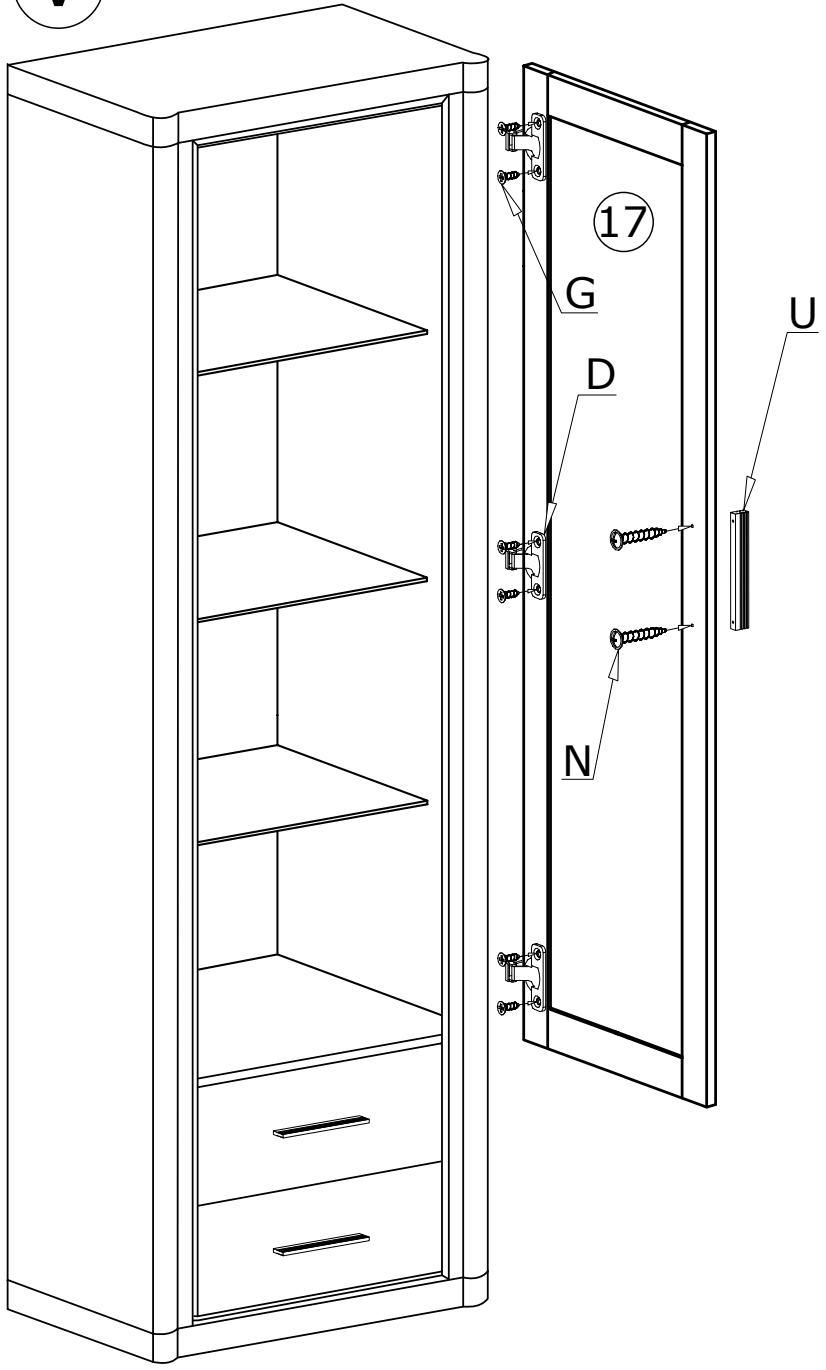
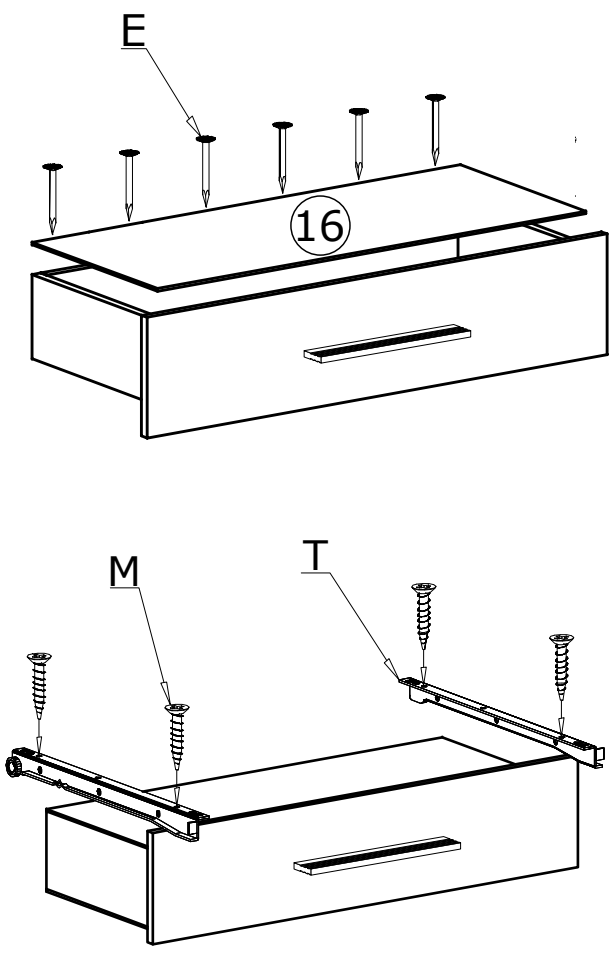

V

LEWA

