

www.MLMEBLE.pl

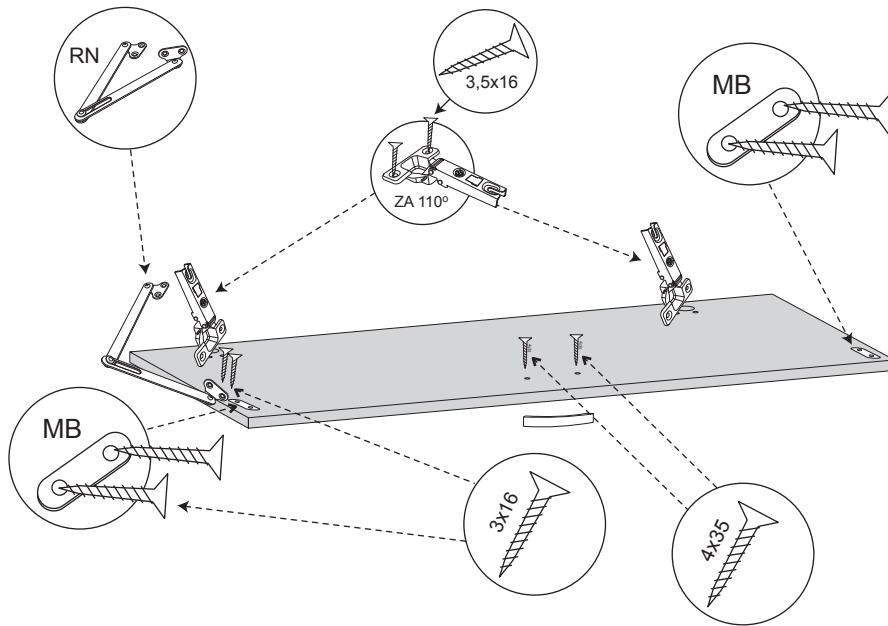

GB assembly instructions / D Montageanleitung / CZ montážní návod / SK montážny návod / RU инструкции по монтажу / LT surinkimo instrukcija



INSTRUKCJA MONTAŻU

PIK 05 N
 ↑53 →90 ↗36

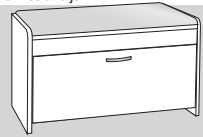

akcesoria / accessories / zubehör / příslušenství / príslušenstvo / аксессуары / furnitūra :

x 12 KK 8/30 	x 6 KT 7/60 	x 4 WT 3,5x16 	x 18 WT 3x16 	x 4 WT 4x30 	x 2 WT 4x35 	x 1 klej / glue / kleber / lepidlo / lepidlo / клей / kijai	x 1 kluczyk / key / schlüssel / klíč / kľúč / ключ / raktas	
x 2 PK H-0 	x 2 ZA 110° 	x 4 WE 6,3x13 	x 50 GZ 1/10 	x 6 ZAK 	x 2 MB 	x 4 PA Ø5 	x 1 UT L96 	
x 1 RN 	x 4 SG 8/8 	x 1 LT 						

do montażu potrzebne są:
 are needed for assembly:
 sind erforderlich für die montage:
 jsou potřebné pro montáž:
 sú potrebné pre montáž:
 которые необходимы для сборки:
 Surinkimui reikės

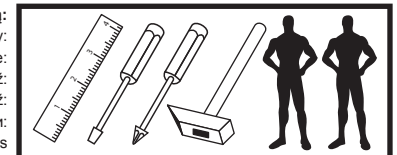

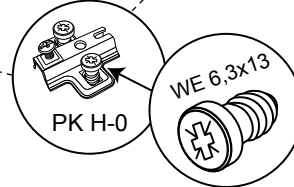
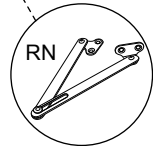
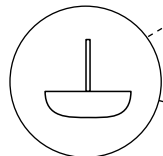
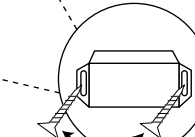
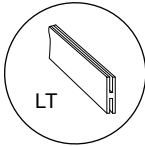
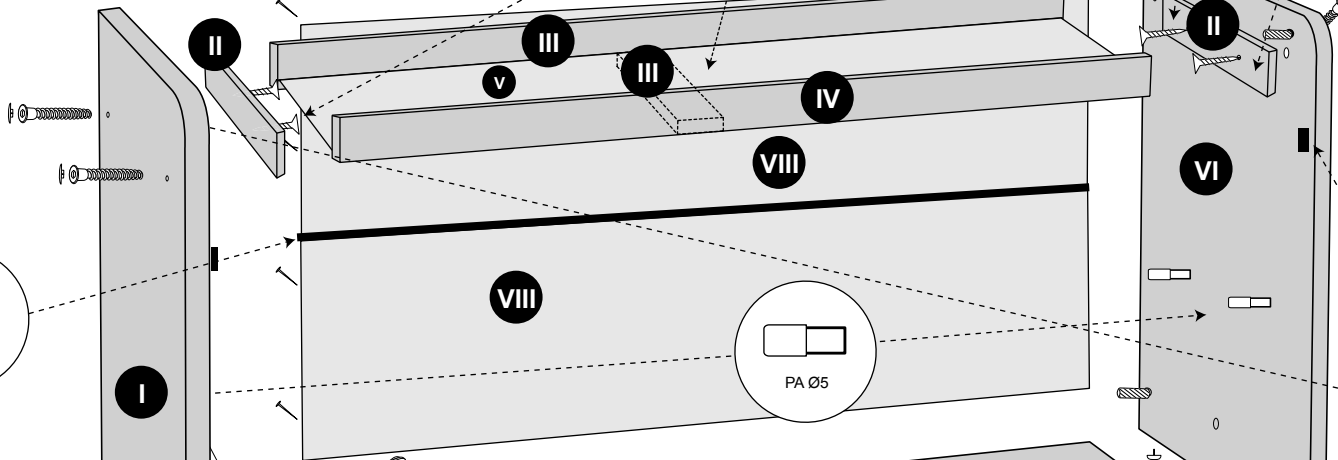
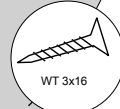
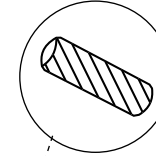
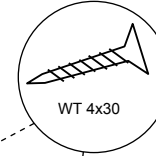
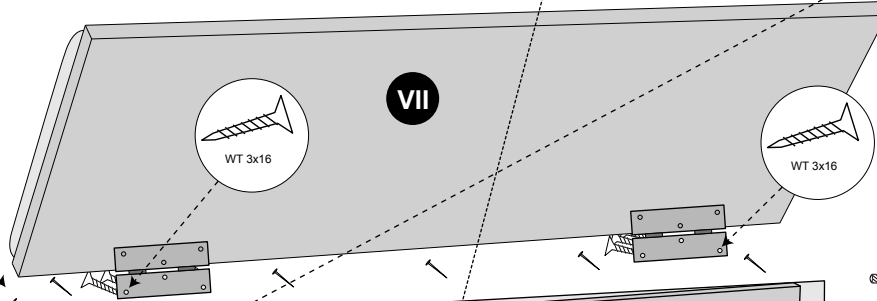
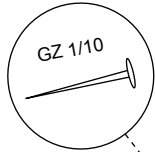
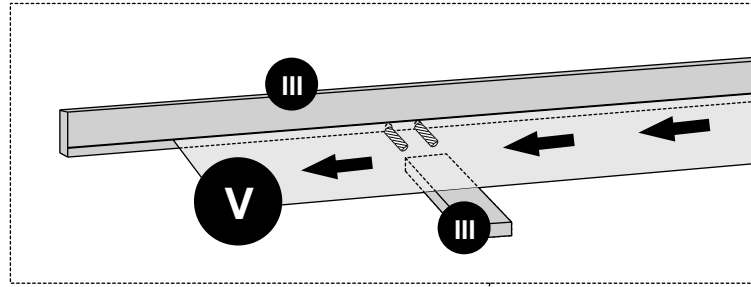
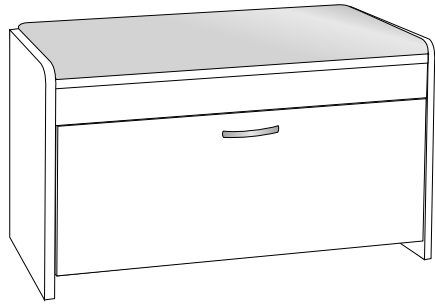

!
UWAGA i - w pierwszej kolejności wbić akcesoria „KK” i „MD” w dół oraz boki.
WARNING! - The first accessory sticks „KK” and „MD” in the tops and sides.
WARNUNG! - Die erste Accessoire-Sticks „KK” und „MD” in den Spitzen und an den Seiten.
POZOR! - První příslušenství holt „KK” a „MD” v korunách a boky.
ПОЗОР! - Первые аксессуары вставляются „KK” и „MD” по верхинам и по бокам.
ВНИМАНИЕ! - Первыи аксесуаров паночки „KK” и „MD” по верхинам и по бокам.
DĚMĚSIO! - Pirmiausiai furnitūrą „KK” ir „MD” įkalame į staličių viršūnes.