

KN	M1	M2	M3	K	S1 4x16
4	4	4	4	8	2

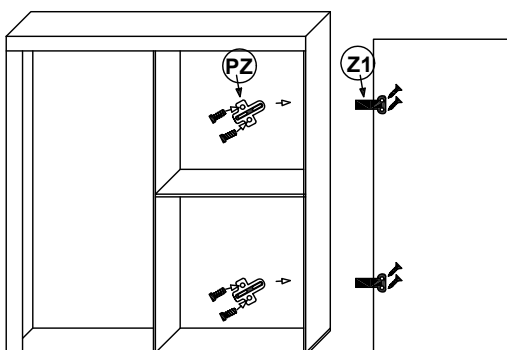

M1	M2	M3	K
25	25	25	25
P	Z1	PZ	G
20	4	4	50

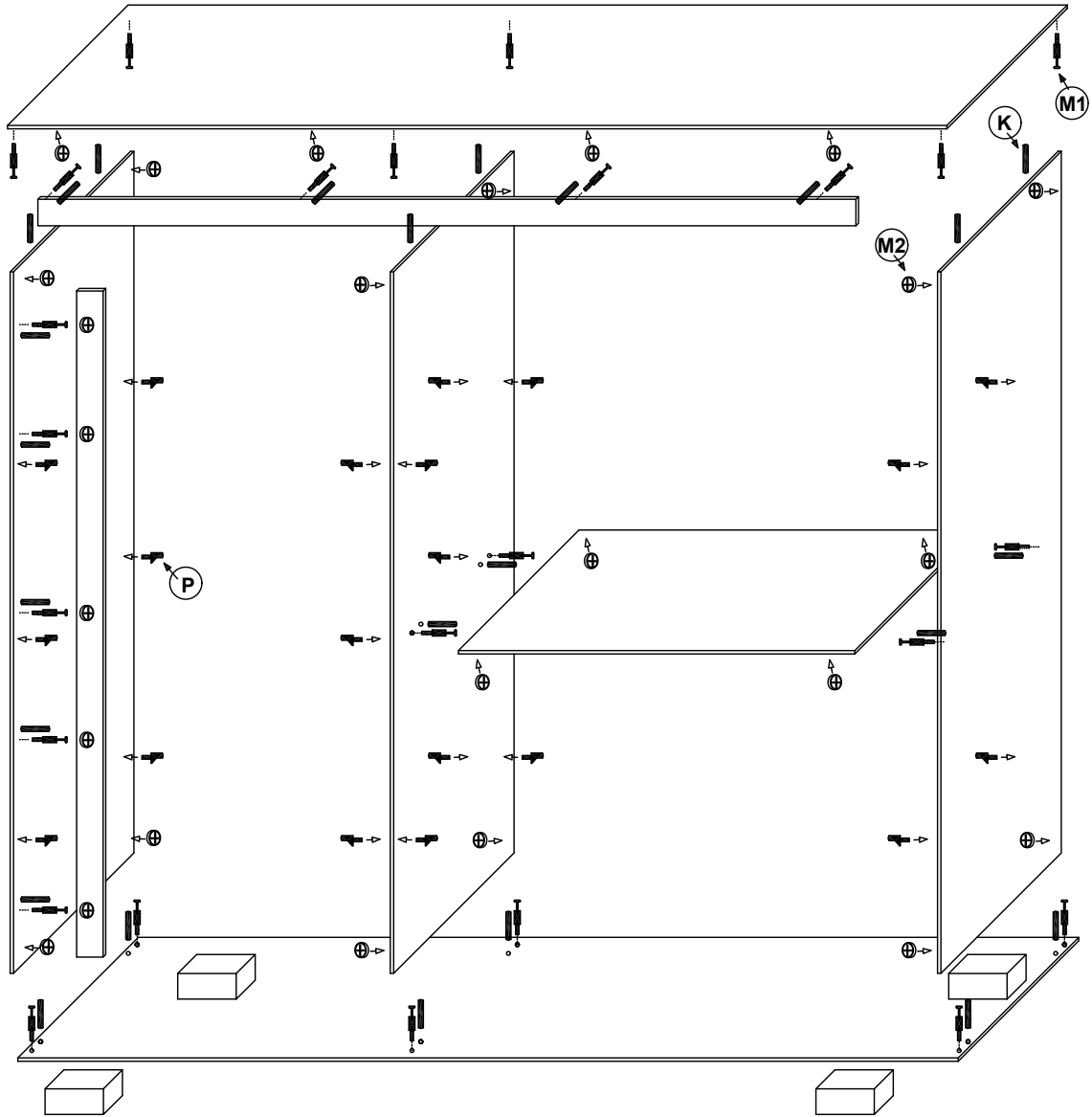
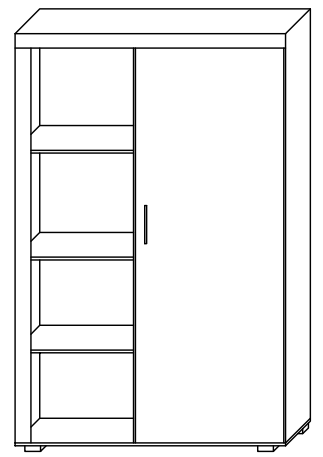
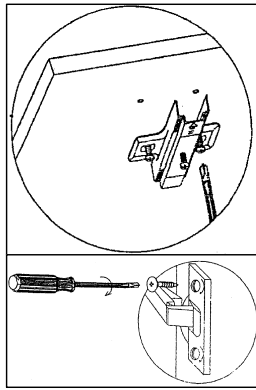
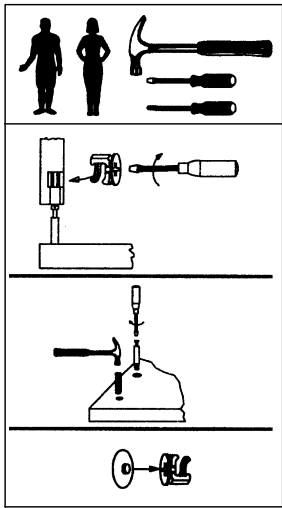
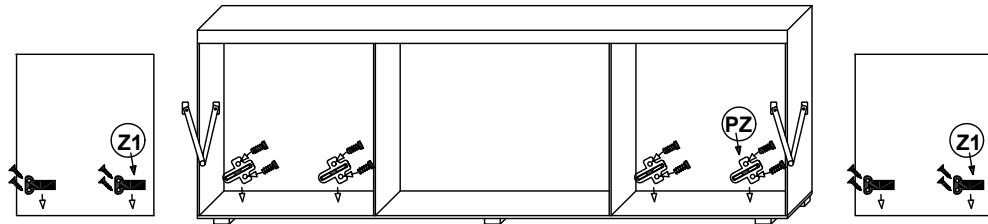
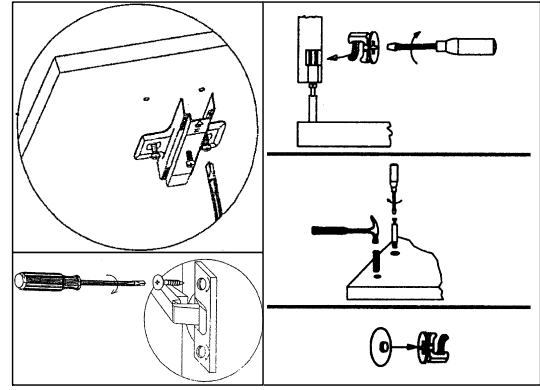
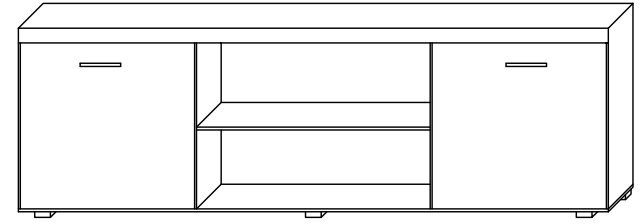
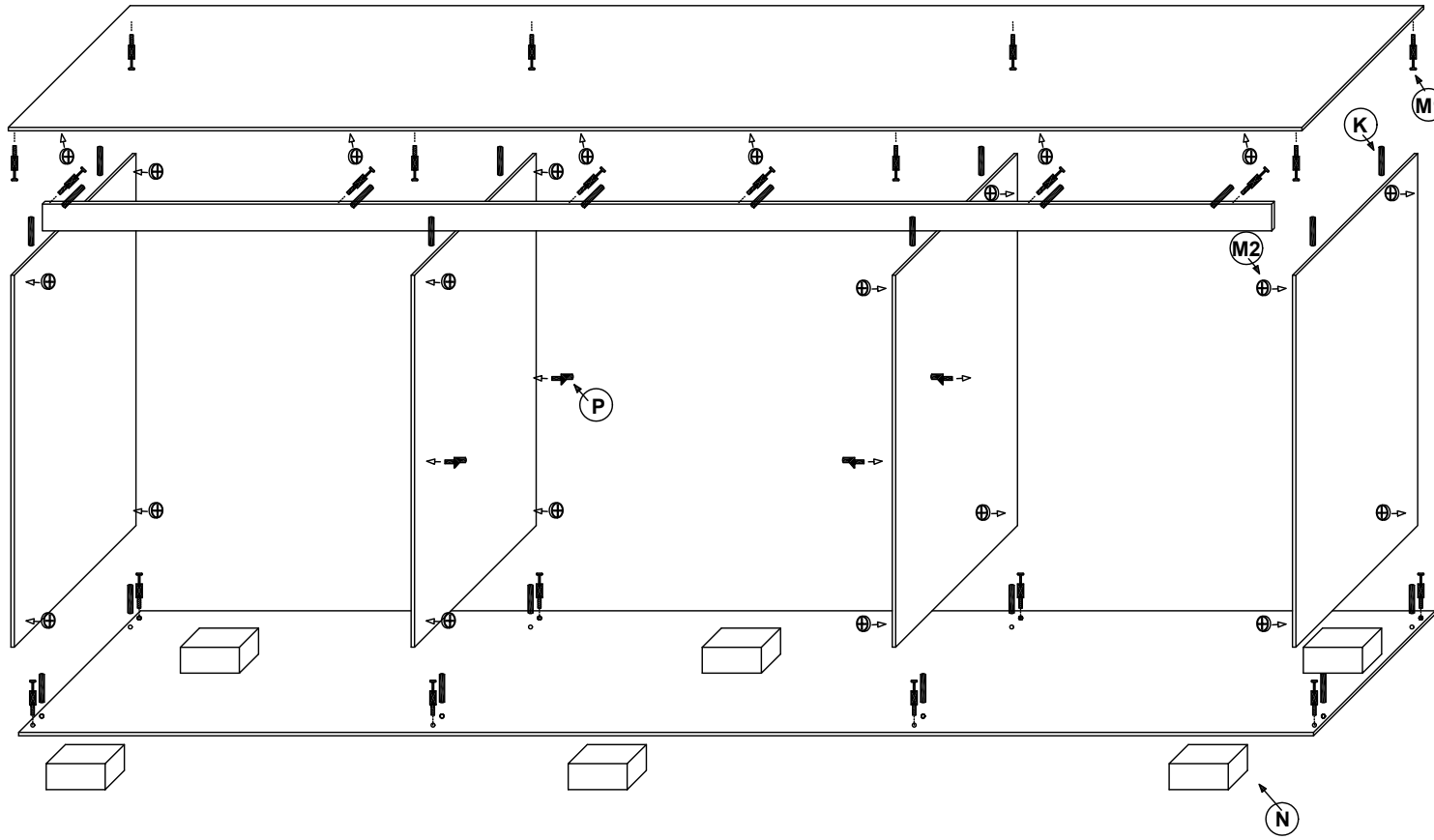
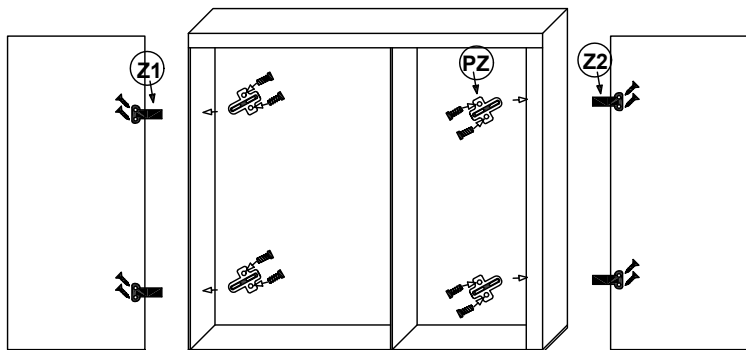
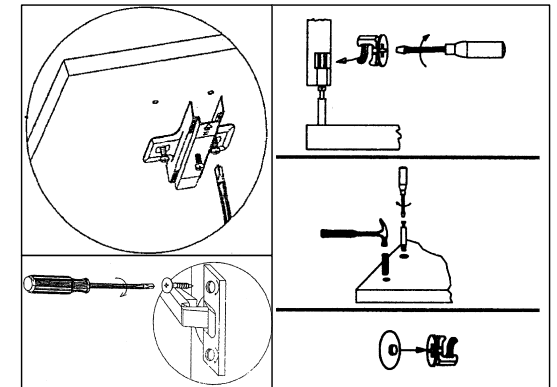
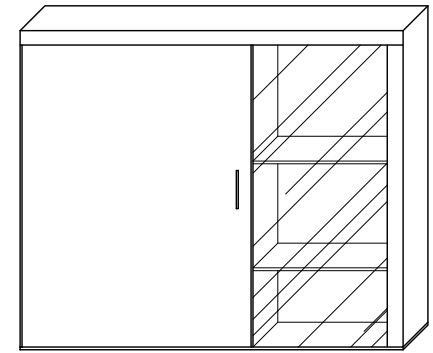
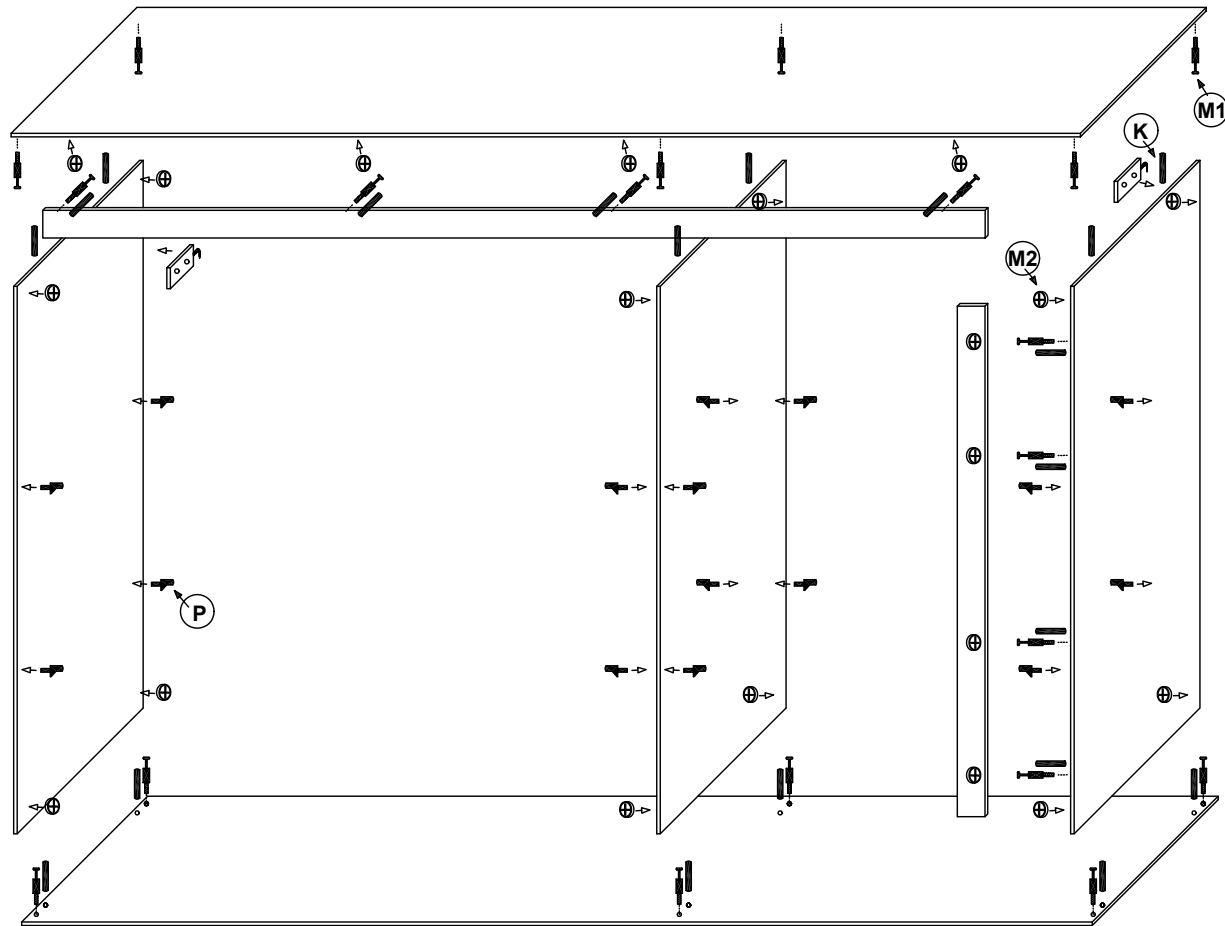

M1	M2	M3	K	P	G
22	22	22	22	4	45



M1	M2	M3	K	P	Z1	PZ	G
20	20	20	20	16	2	4	40