

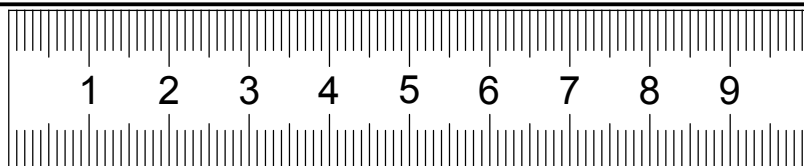

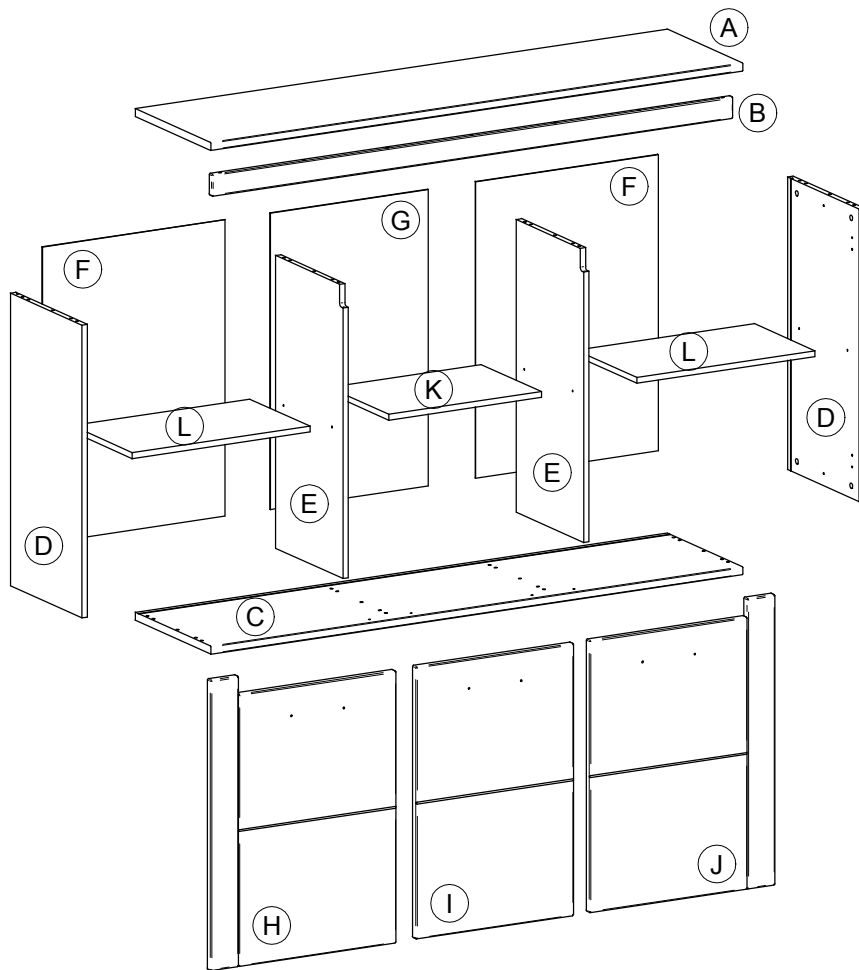

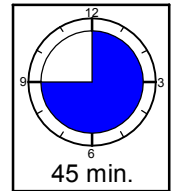

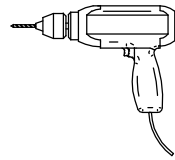

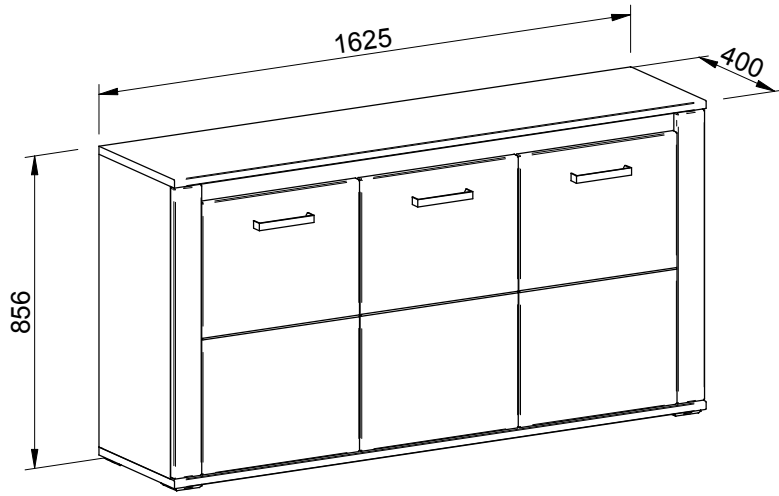
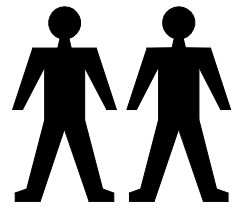
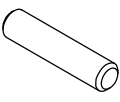
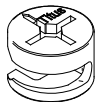
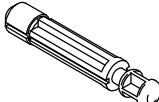

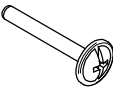
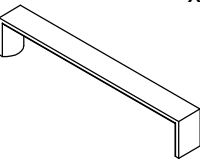
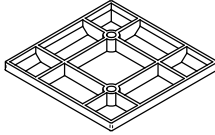

VERONA 51

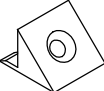

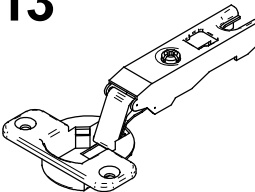
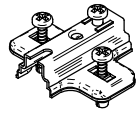
1 ø8x35 x32 	2 ø15 x16 	3 ø8 x16 	4 ø5 x3 	5 ø4x23 x6 
6 x3 	7 x6 	8 ø3,5x15 x14 	9 ø3,5x20 x28 	10 ø12 x12 
11 x16 	12 ø15 x16 	13 x4 	14 x6 	15 ø5 x12 
16 x1  Vor Gebrauch schütteln Shake before use Pred použitím zatrepáť	17 x6 	18 x1 	19 ø4x20 x12 	20 x2 

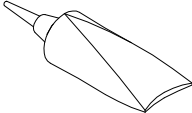
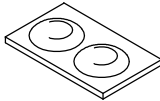
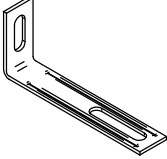

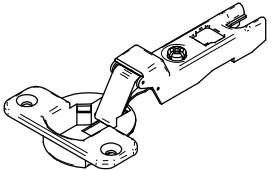
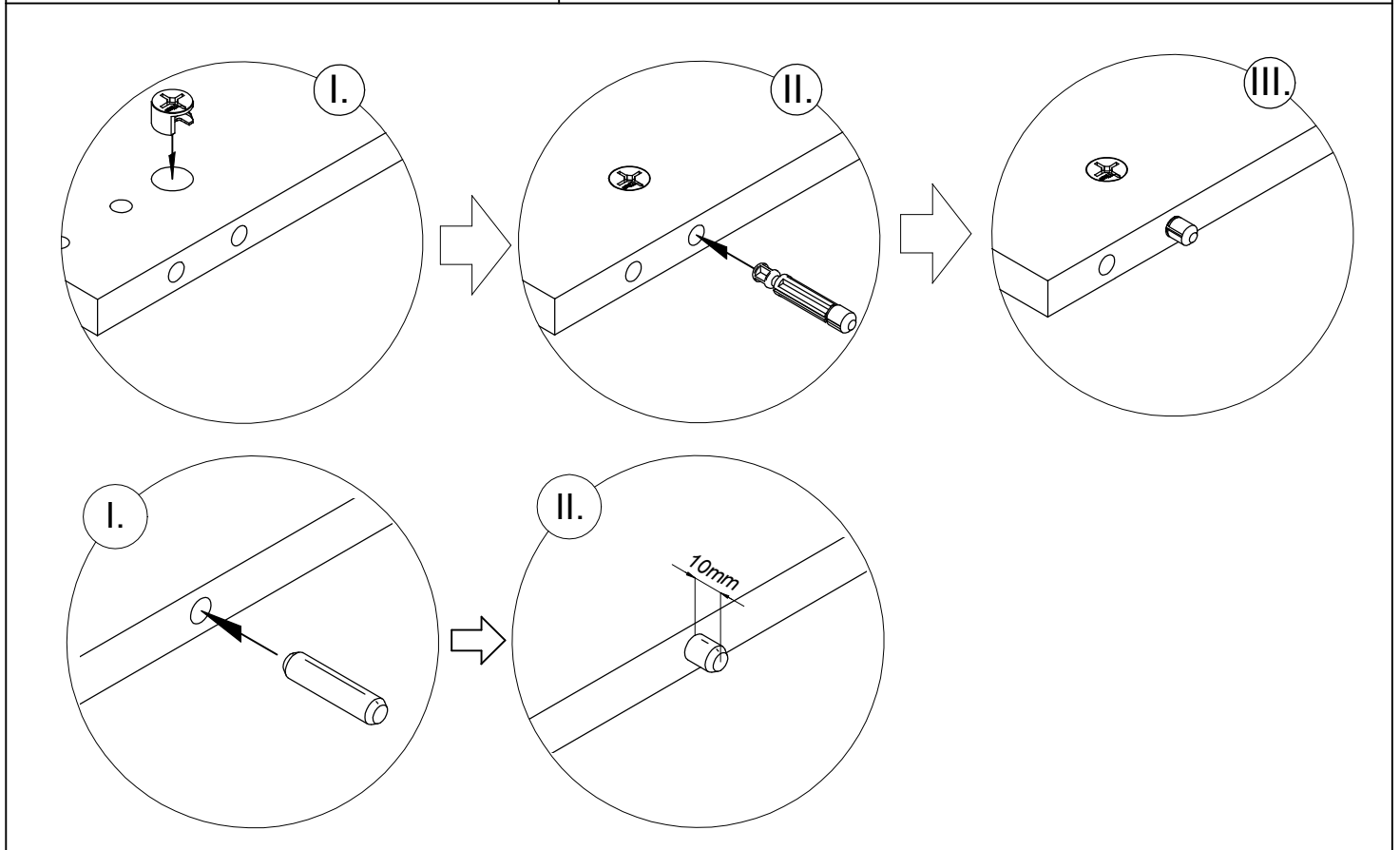
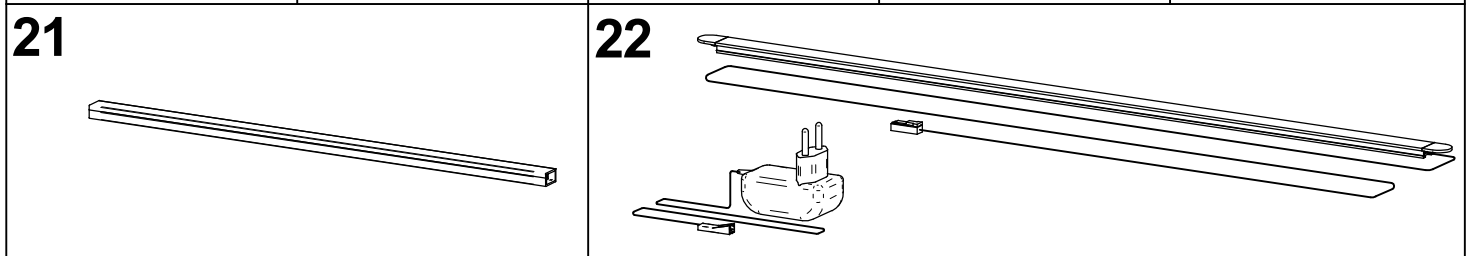
1.

1.1

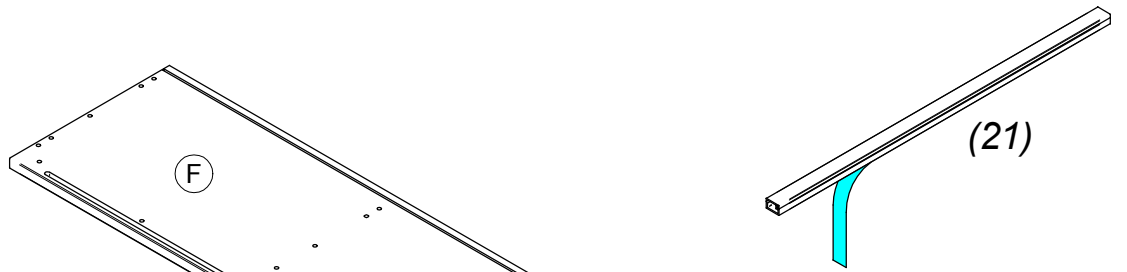

1.2

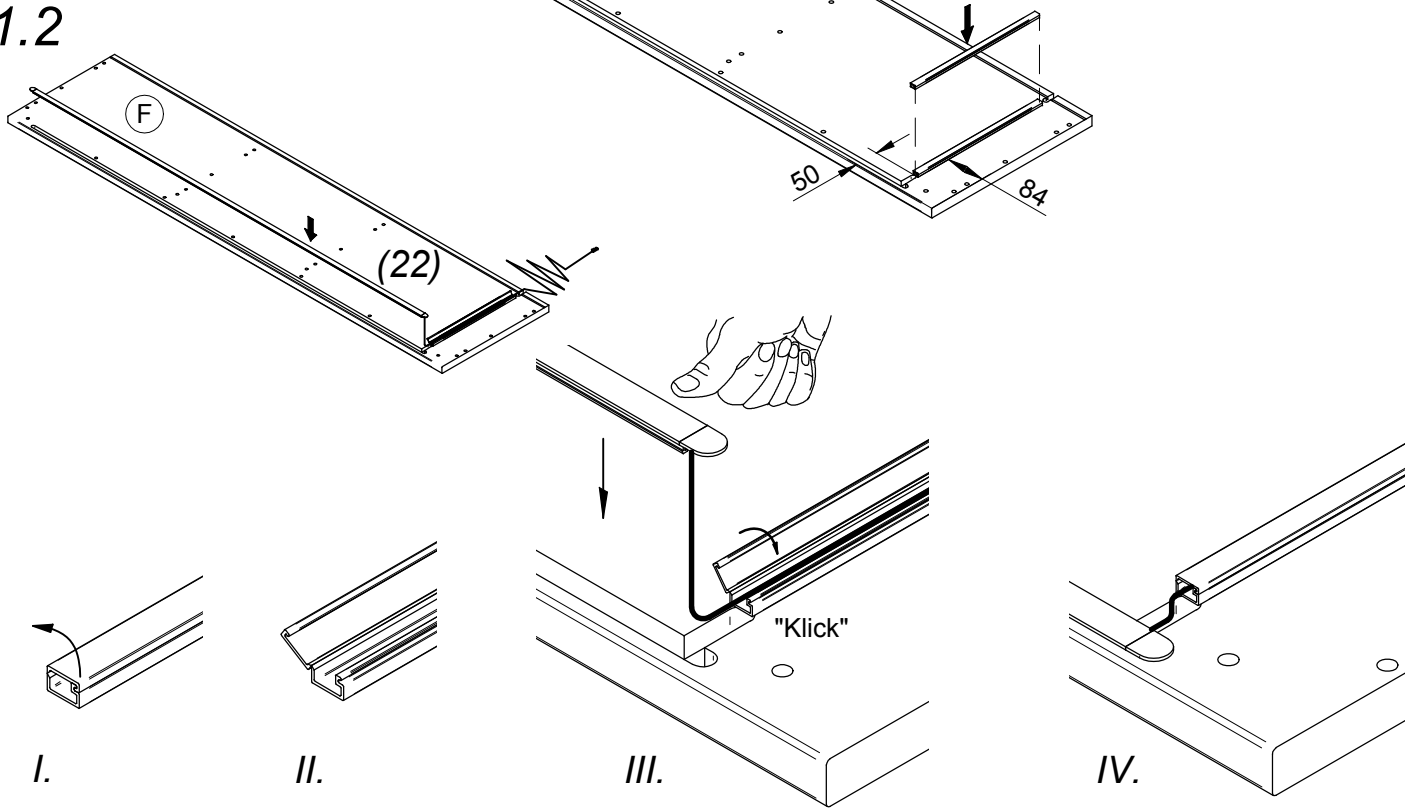

1.3

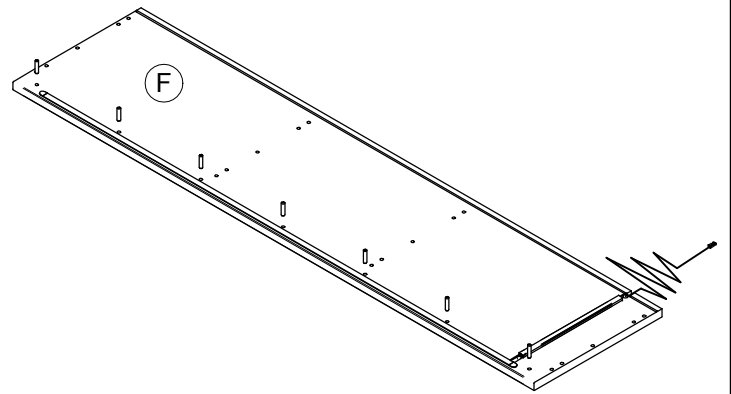
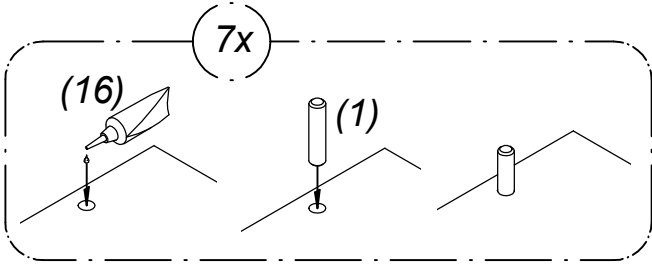

1.4

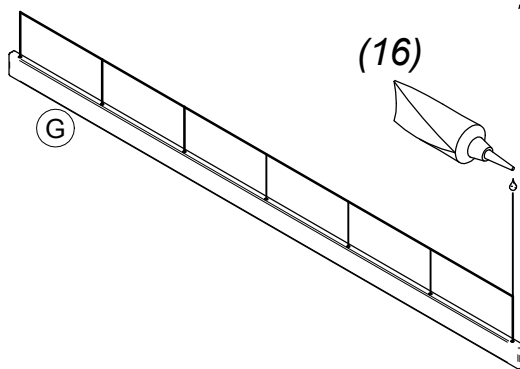

1.5

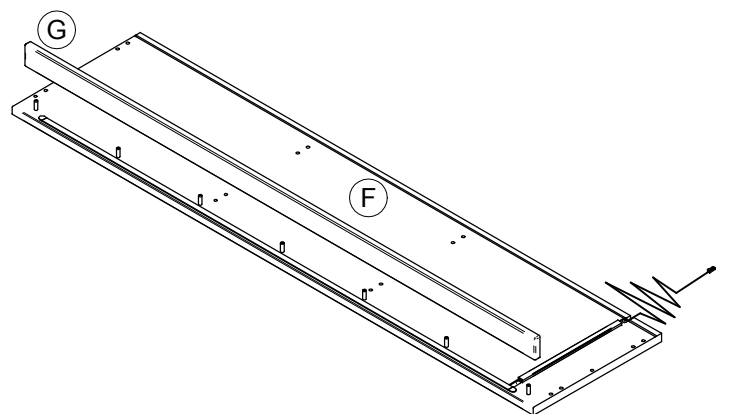

2.

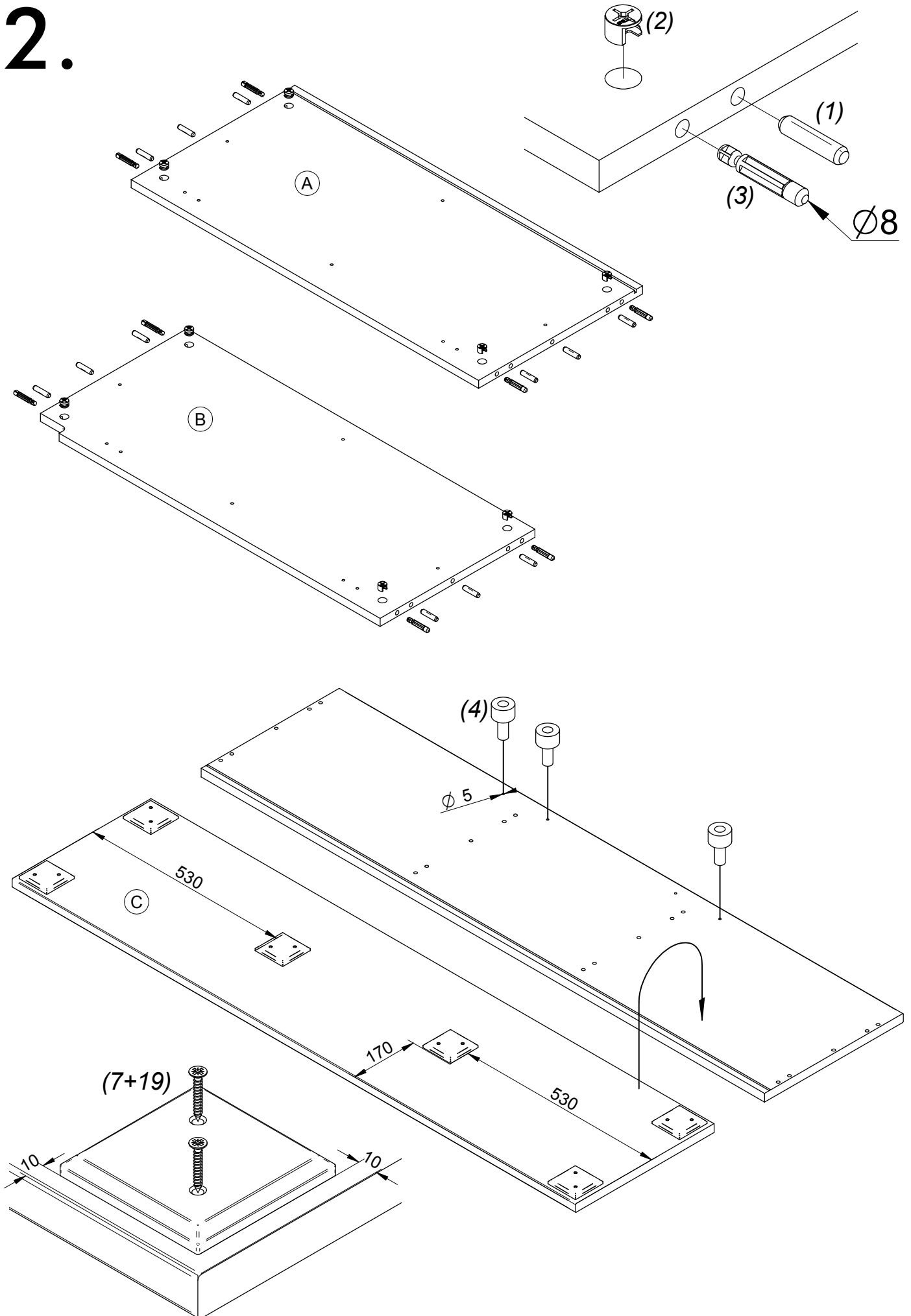

3.

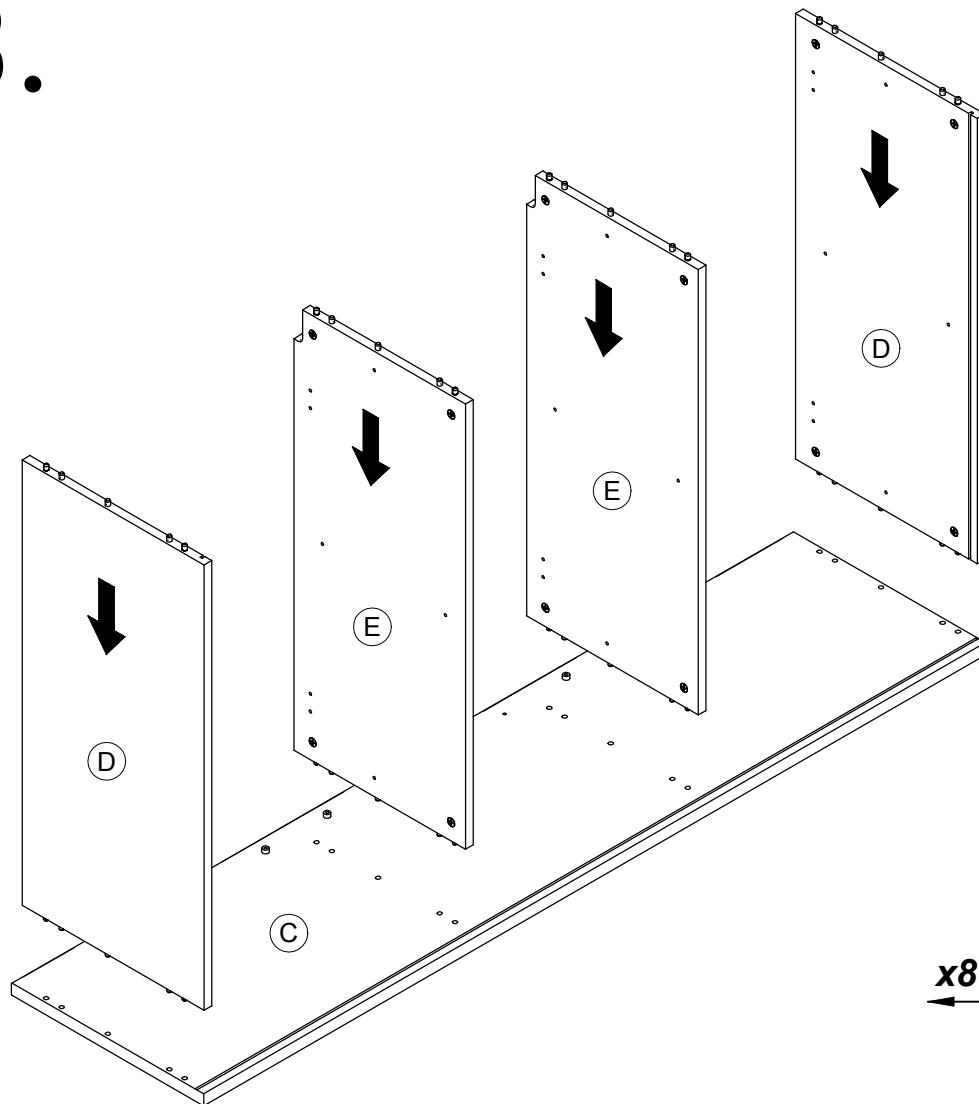

4.

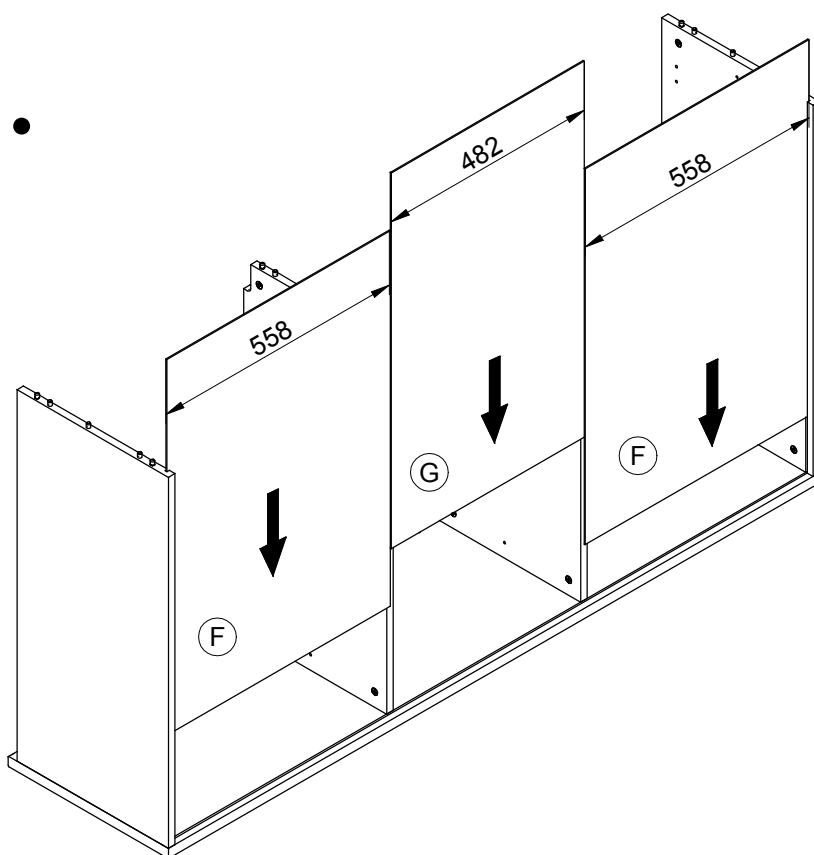

5.

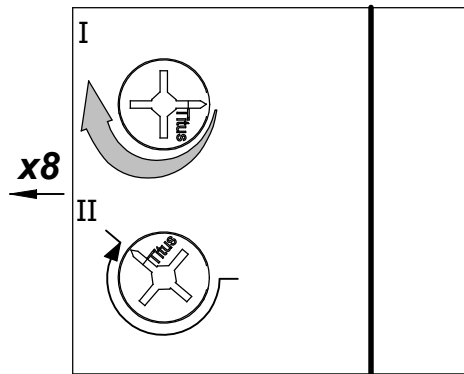
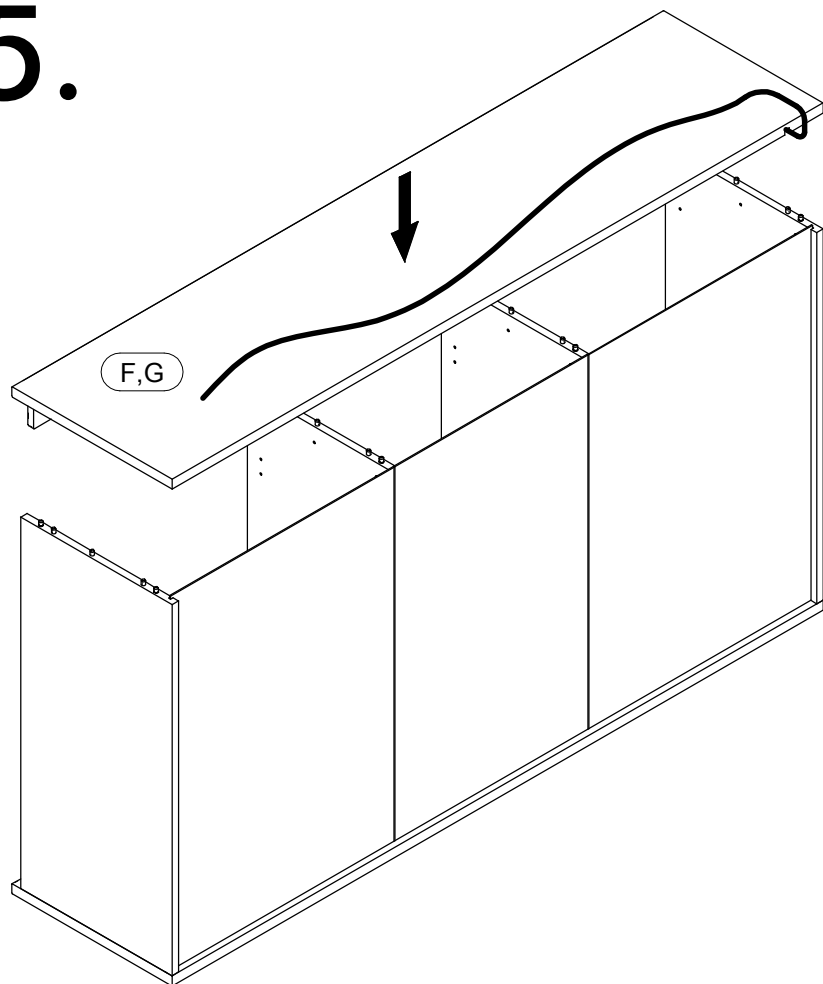

6.

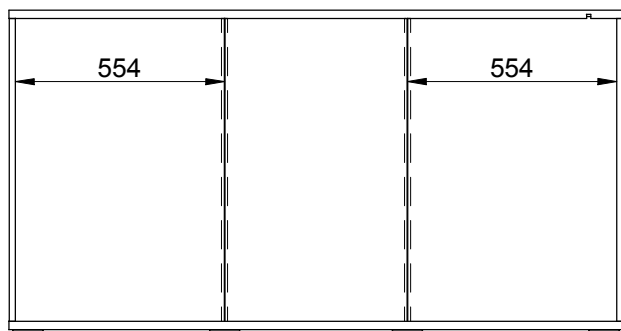
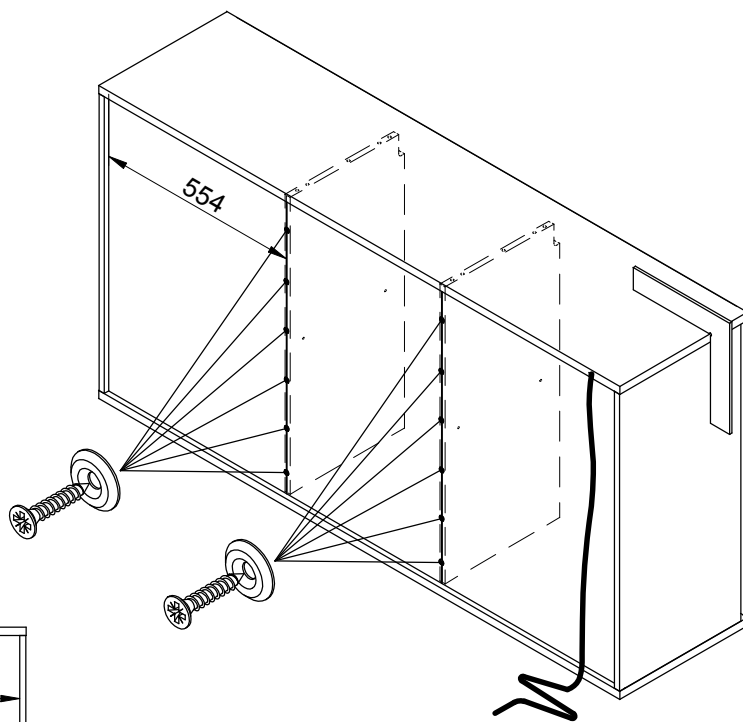
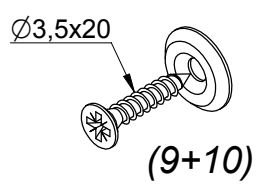

7.

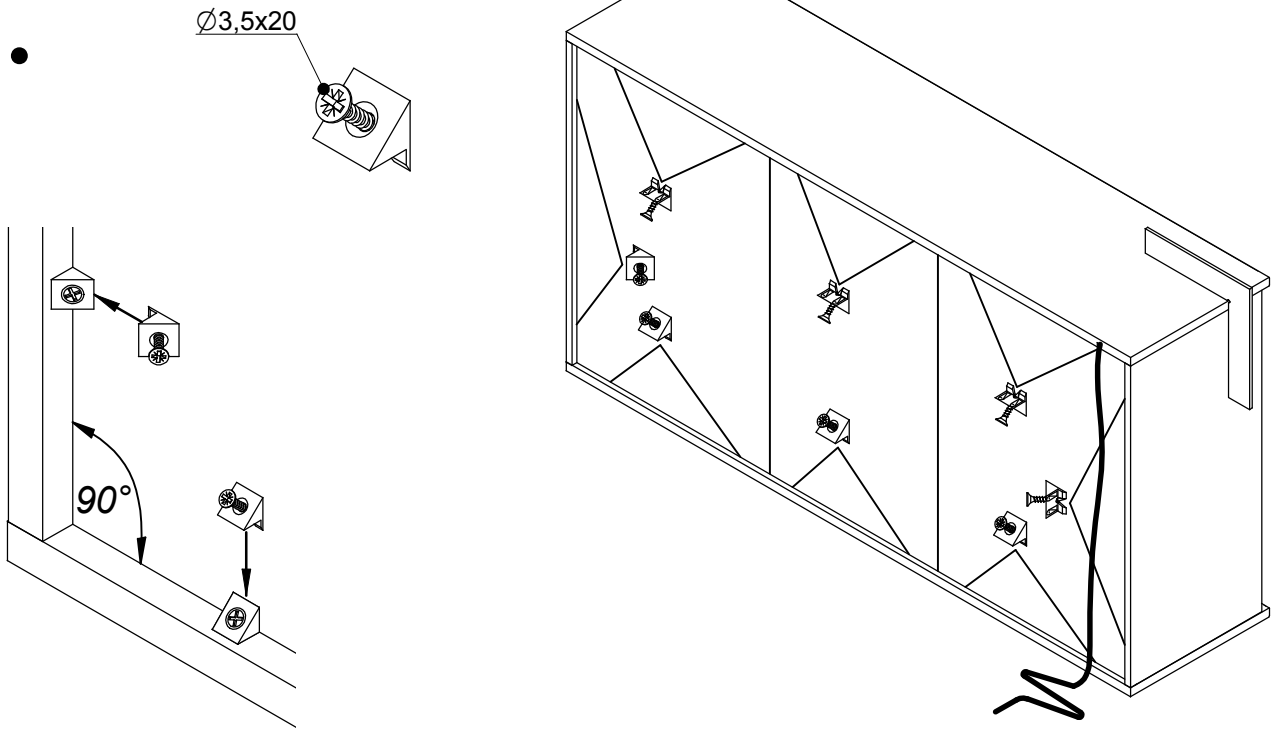

8.

Wenn Möbelstücke umkippen, können ernste oder lebensgefährliche Verletzungen durch Einklemmen die Folge sein. Um zu verhindern, dass das Möbelstück umkippt, muss es fest an der Wand verankert werden. Beschläge für die Wandbefestigung sind nicht beige packt, da sie von der jeweiligen Wandbeschaffenheit abhängig sind. Befestigungsbeschläge benutzen, die für die heimischen Wände geeignet sind. Bei diesbezüglichen Fragen den örtlichen Fachhandel zu Rate ziehen.

Prevrnutie nábytku môže spôsobiť vážne či smrteľné zranenia. Aby sa zabránilo prevrhnutiu nábytku, upevnite ho ku stene. Upevňovací materiál nie je súčasťou balenia, pretože na každý materiál steny je potrebné použiť iný typ skrutky a hmoždinky. Použite taký upevňovací materiál, ktorý je vhodný na konkrétny typ steny u vás doma. V prípade potreby sa poraďte s odborníkom.

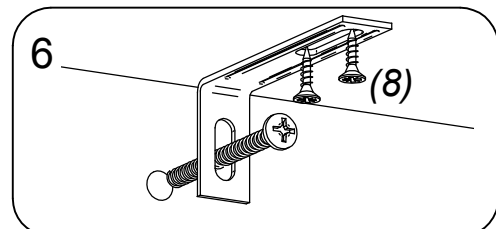
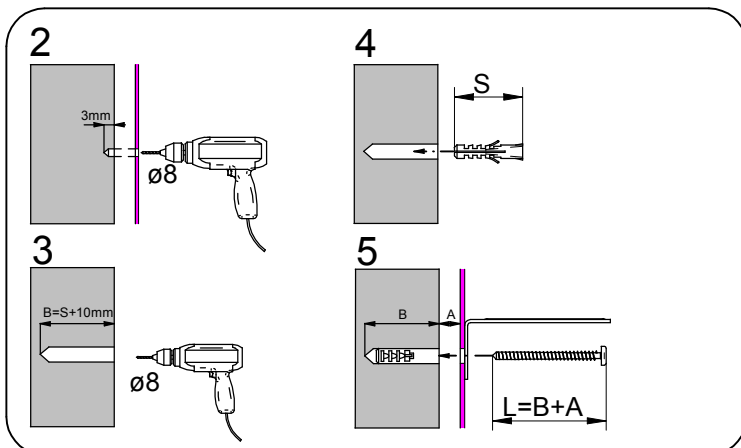
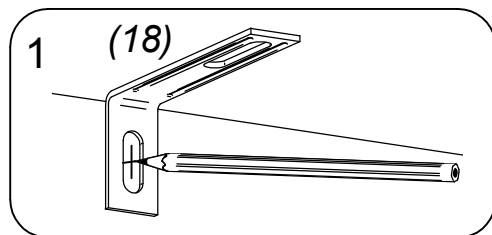
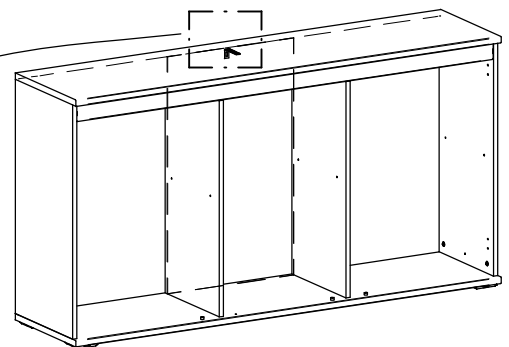
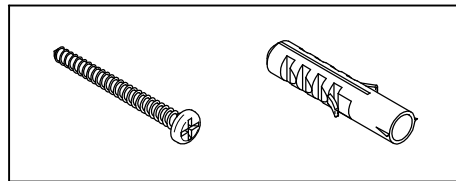

9.

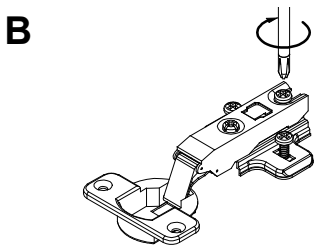
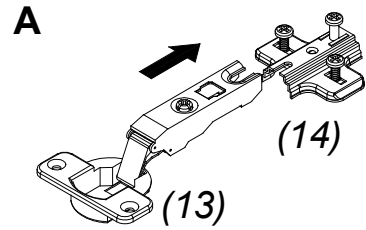
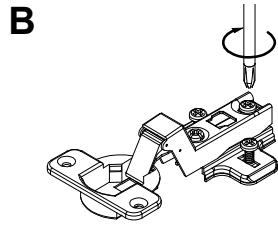
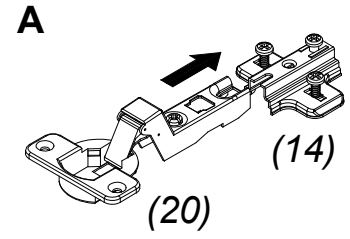
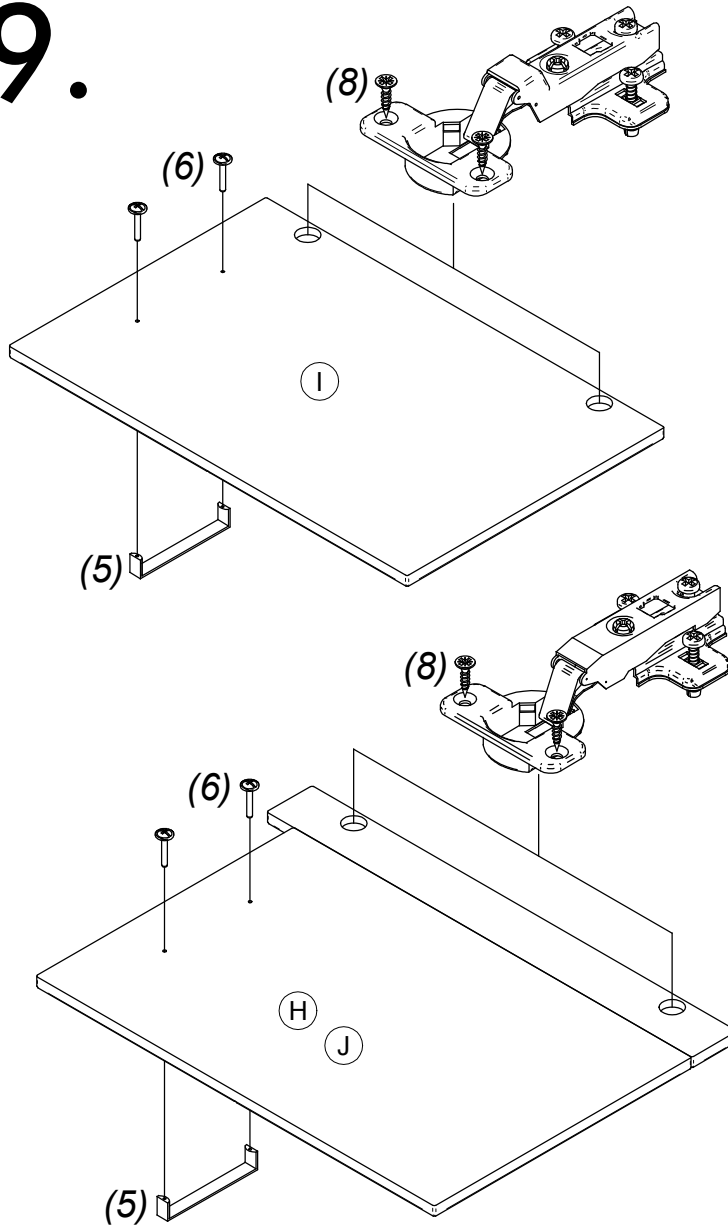

10.

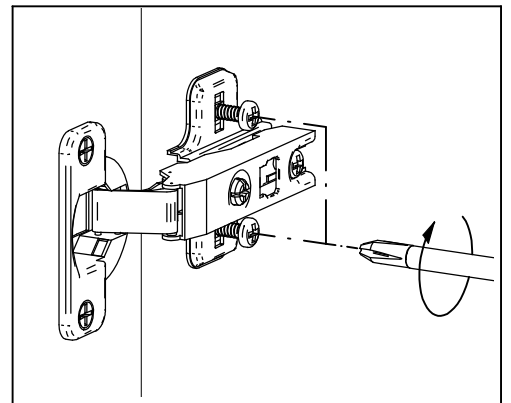
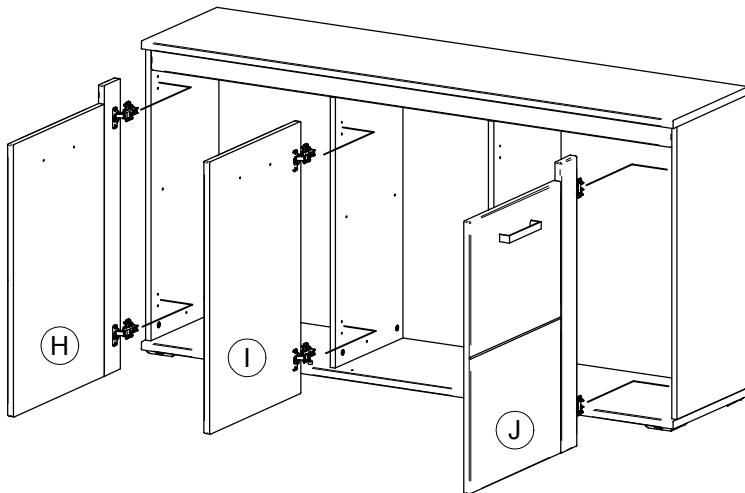

11.

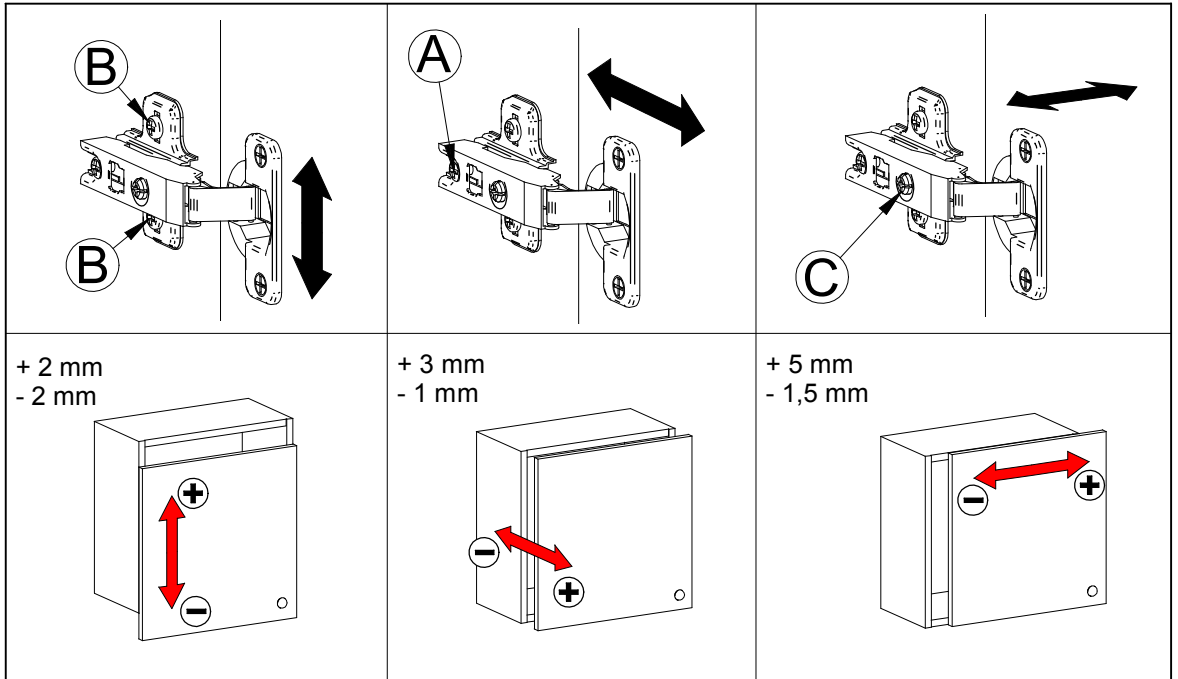

12.

