

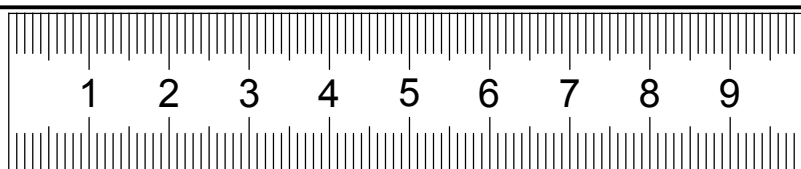

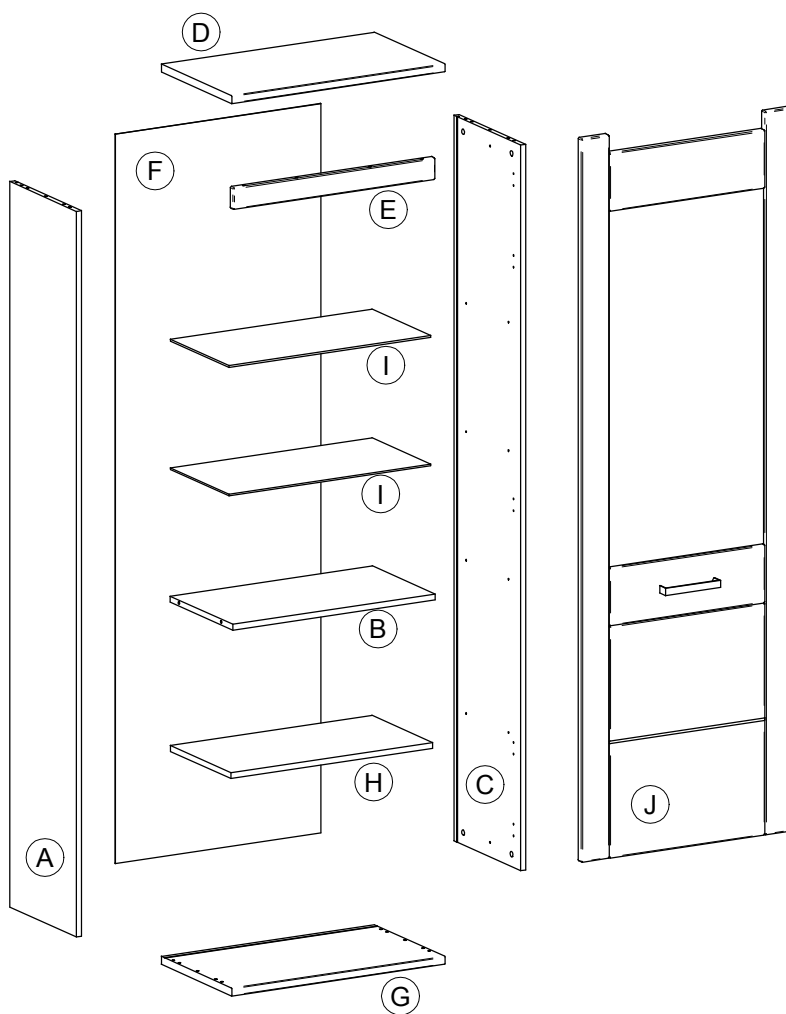

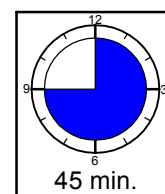

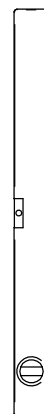
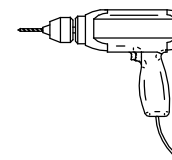
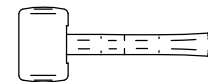
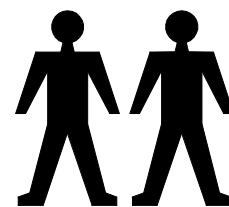
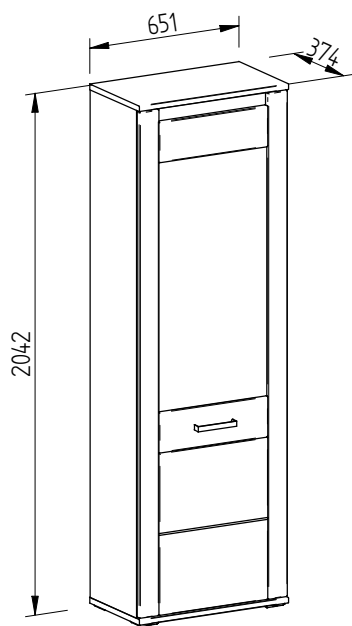
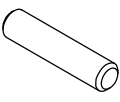
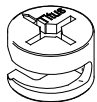
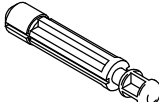
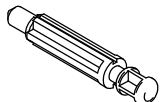
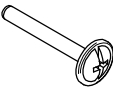
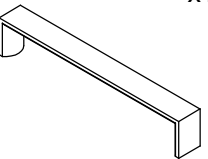
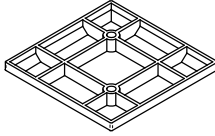

VERONA 01

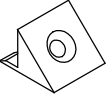
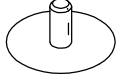
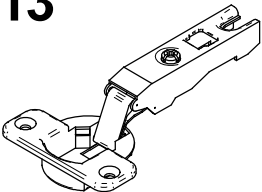
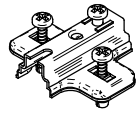

1 $\varnothing 8 \times 35$ x16 	2 $\varnothing 15$ x12 	3 $\varnothing 8$ x8 	4 $\varnothing 5$ x4 	5 $\varnothing 4 \times 23$ x2 
6 x1 	7 x4 	8 $\varnothing 3,5 \times 15$ x12 	9 $\varnothing 3,5 \times 20$ x16 	10 $\varnothing 12$ x3 
11 x16 	12 $\varnothing 15$ x12 	13 x5 	14 x5 	15 $\varnothing 5$ x4 
16 $\varnothing 5$ x8 	17 x1  Vor Gebrauch schütteln Shake before use Pred použitím zatrepaj	18 x2 	19 x1 	20 $\varnothing 4 \times 20$ x8 
21 	22 			

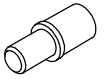
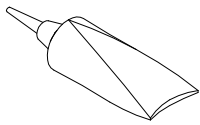
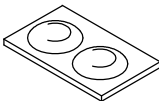
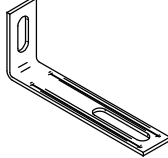

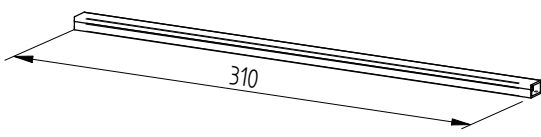
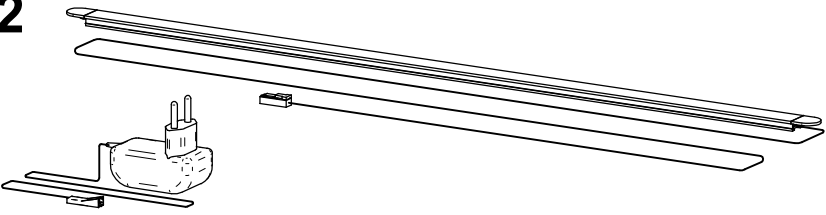
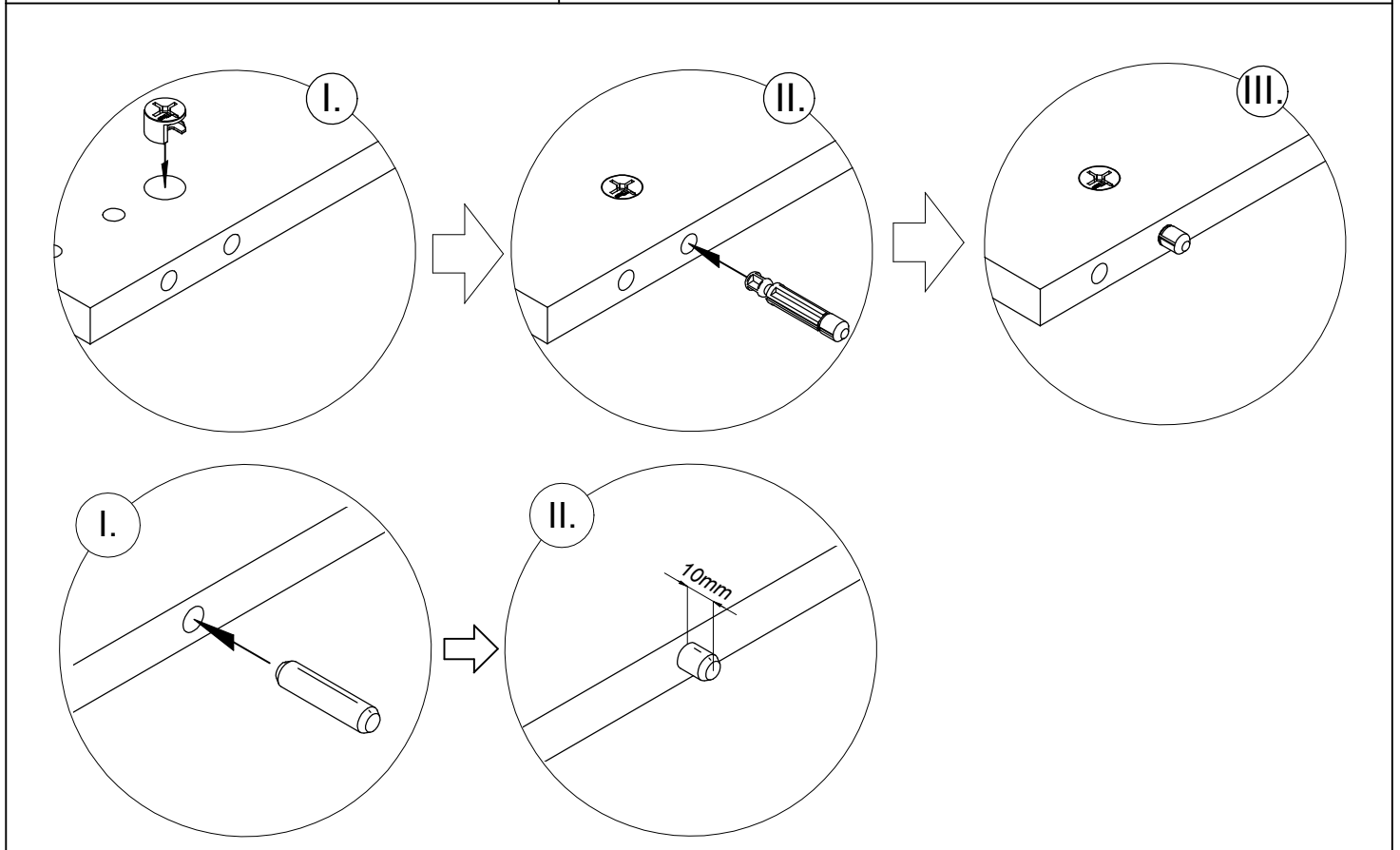
1.

1.1

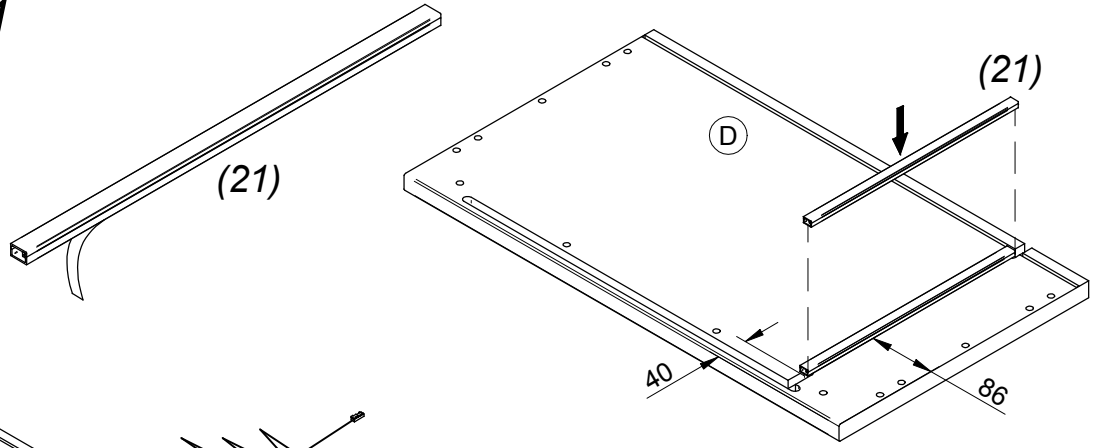

1.2

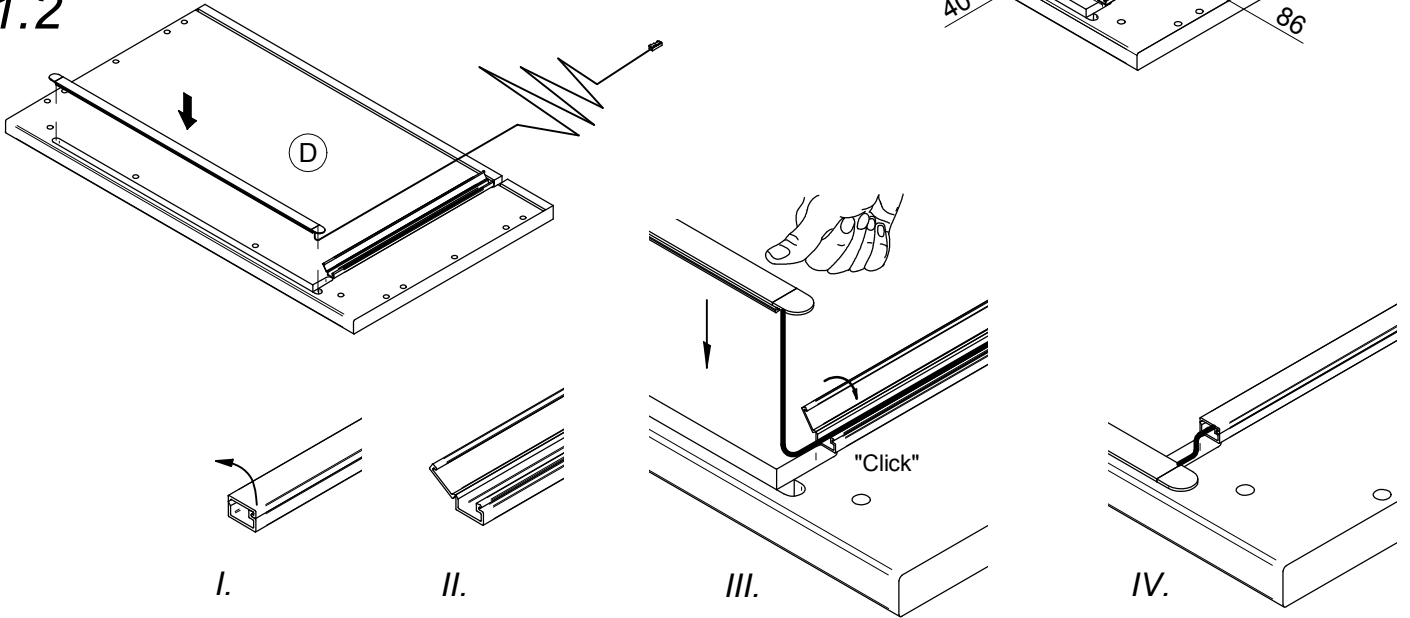

1.3

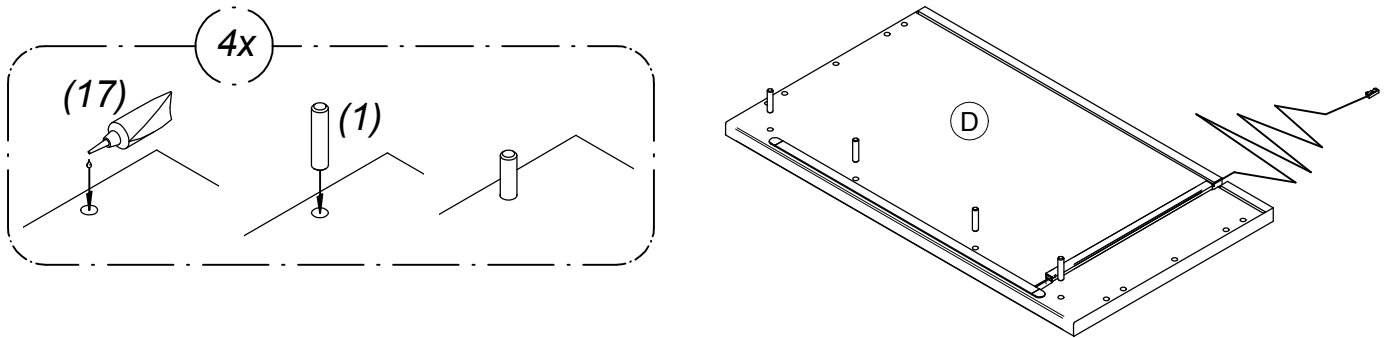

1.4

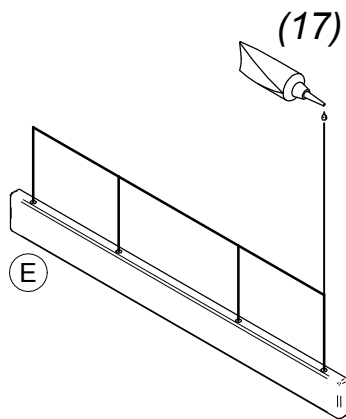

1.5

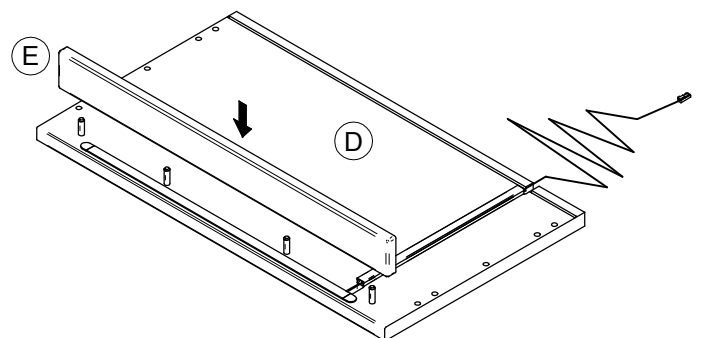

2.

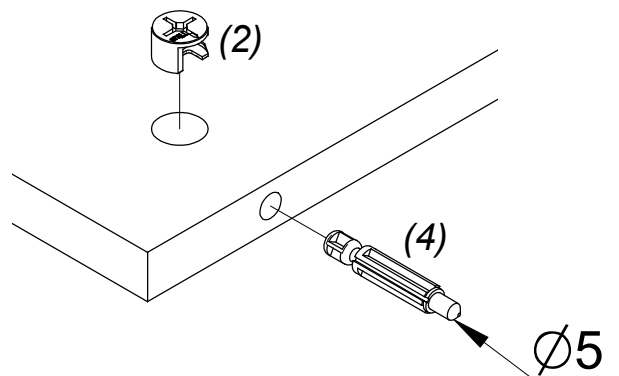
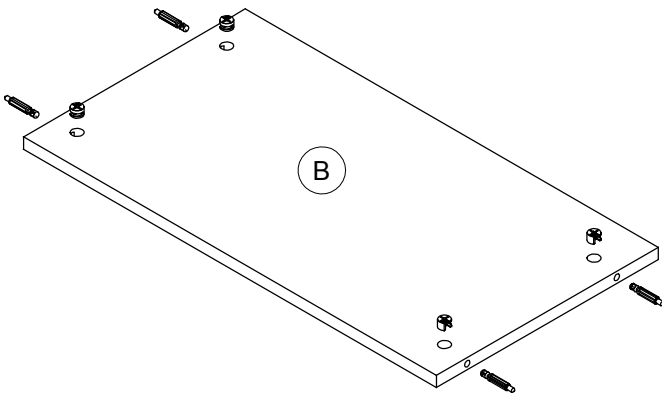
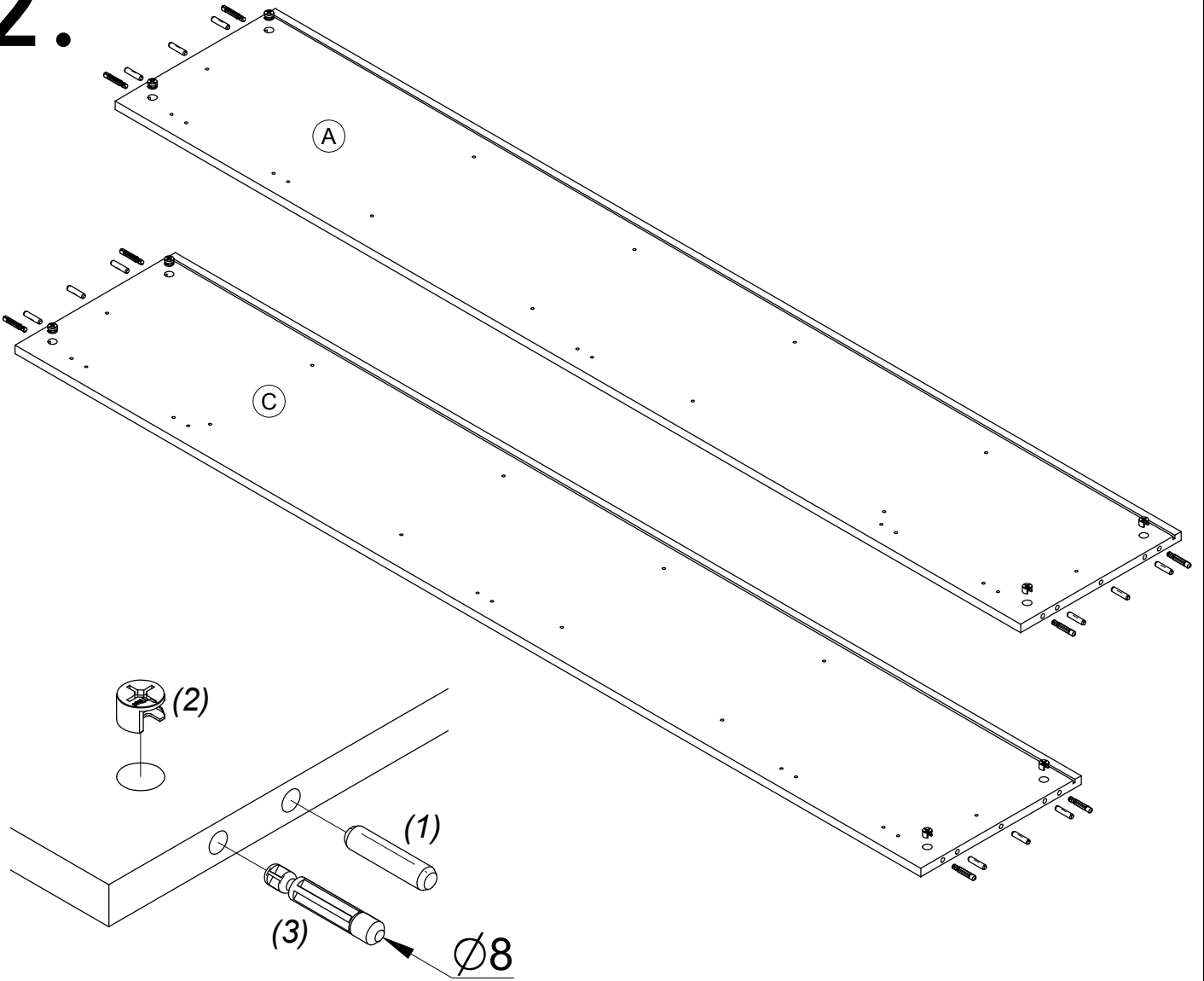

3.

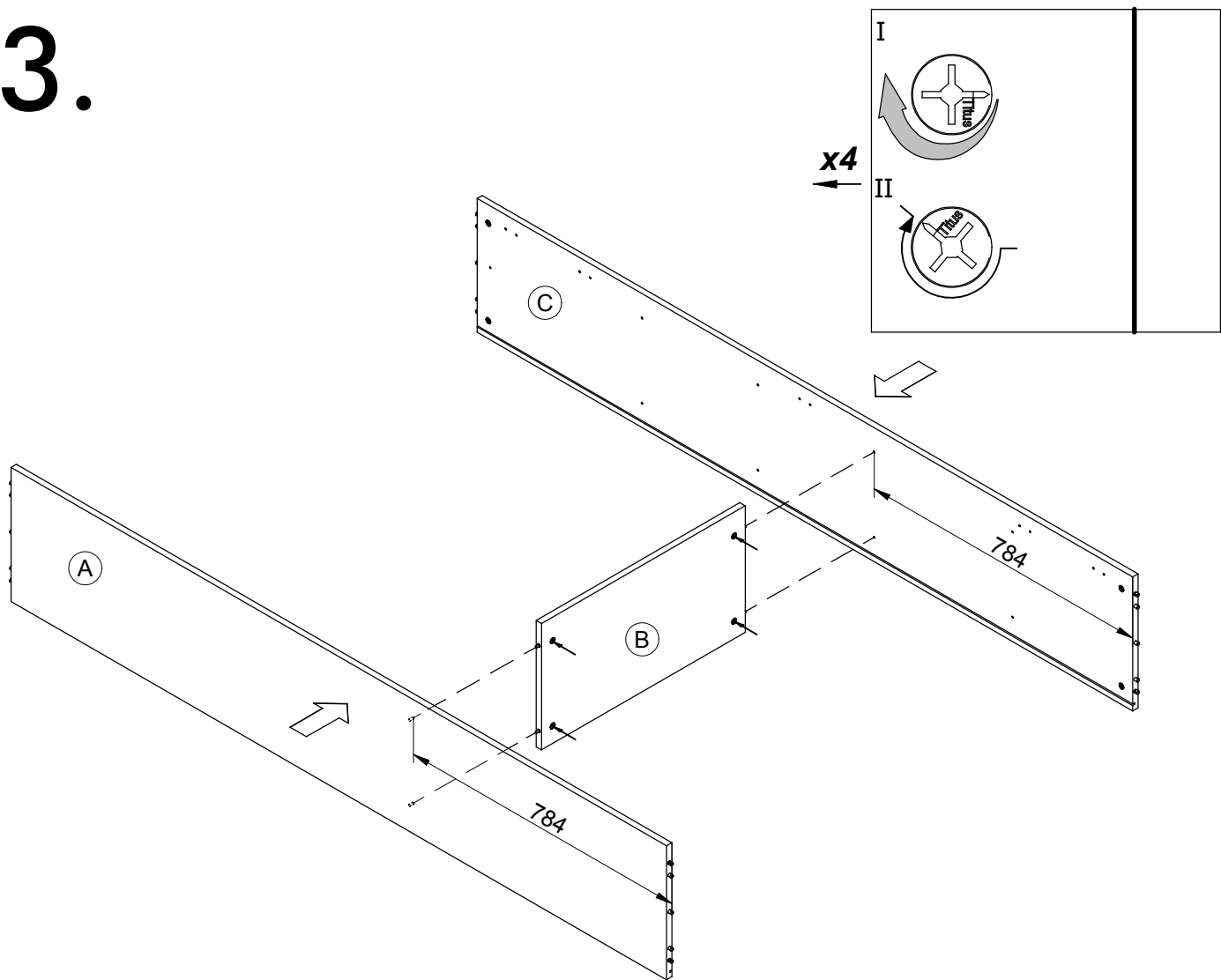

4.

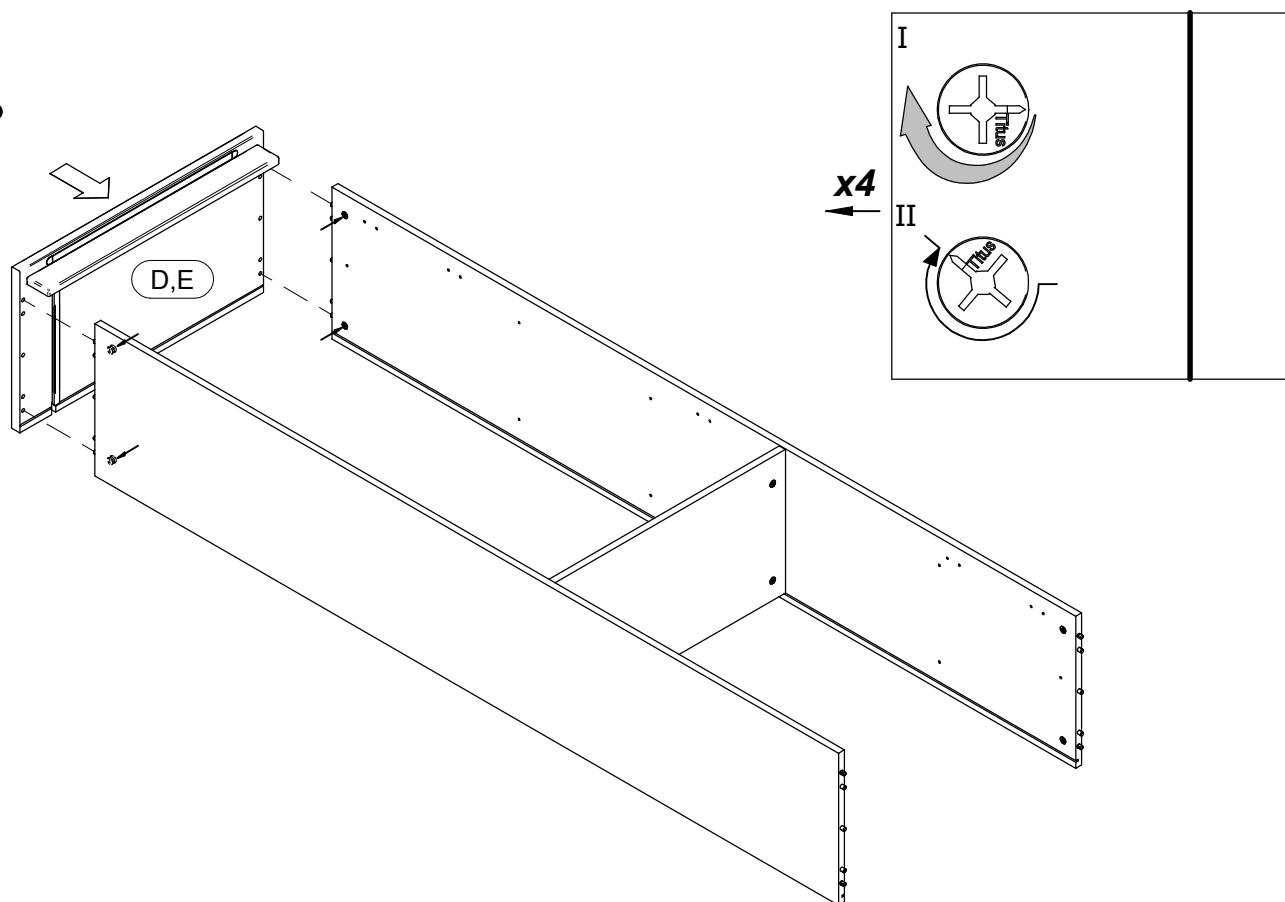

5.

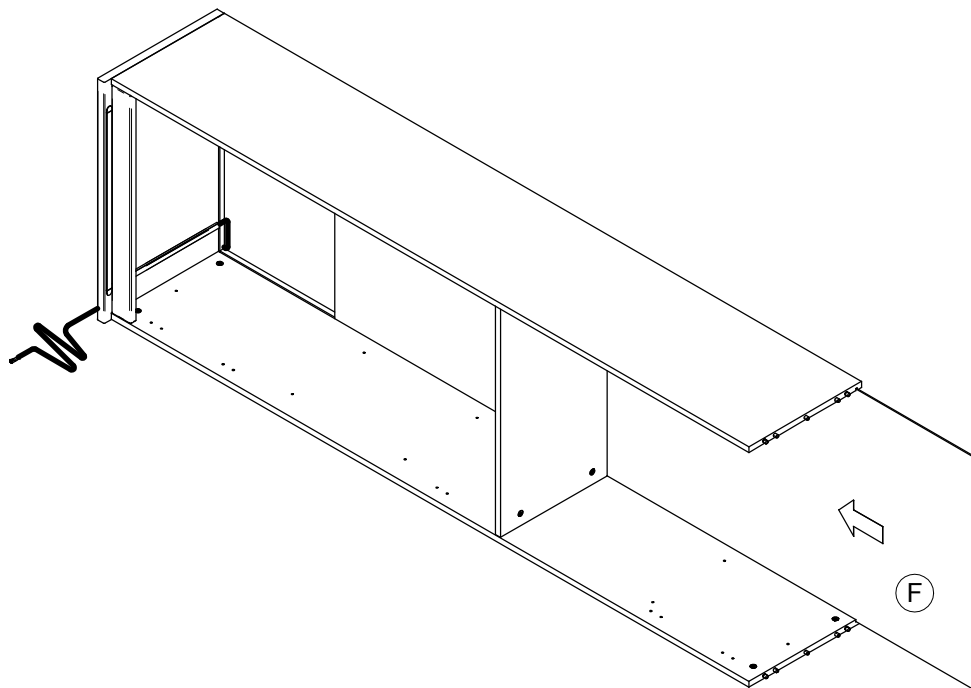

6.

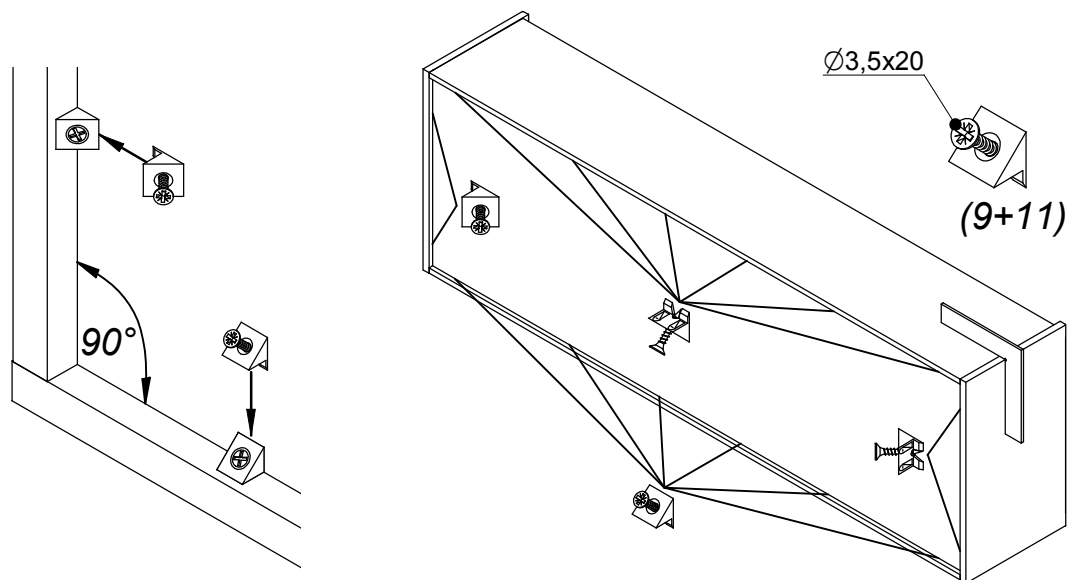
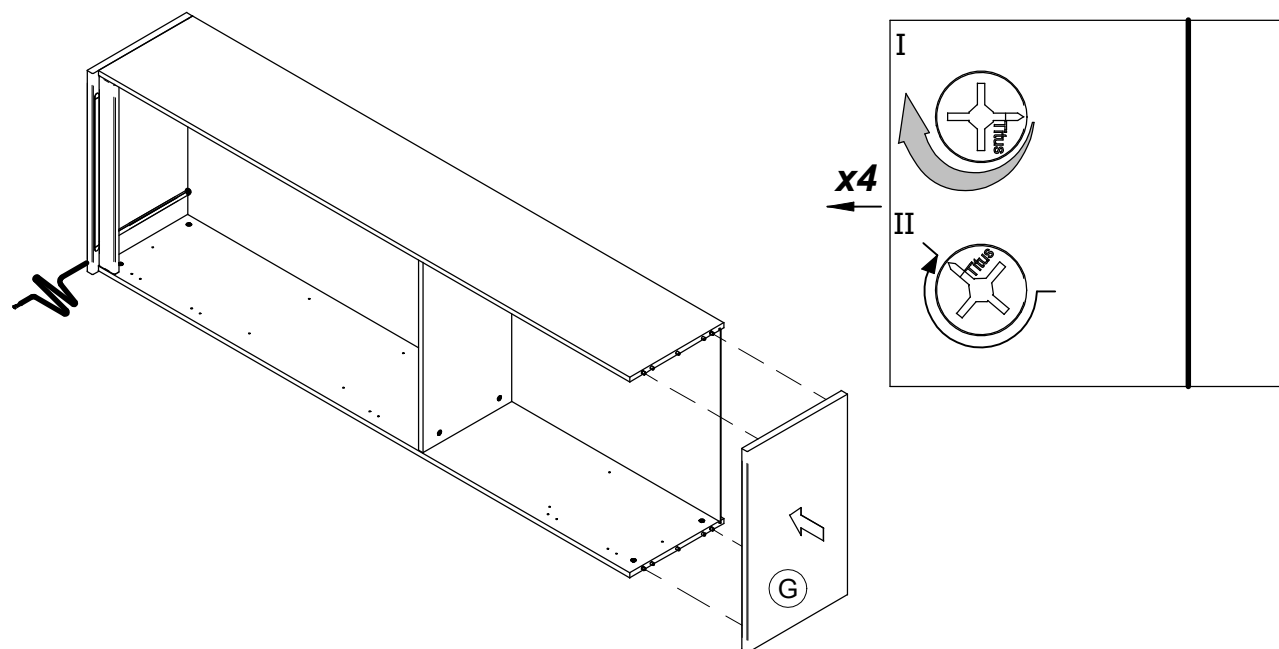

7.

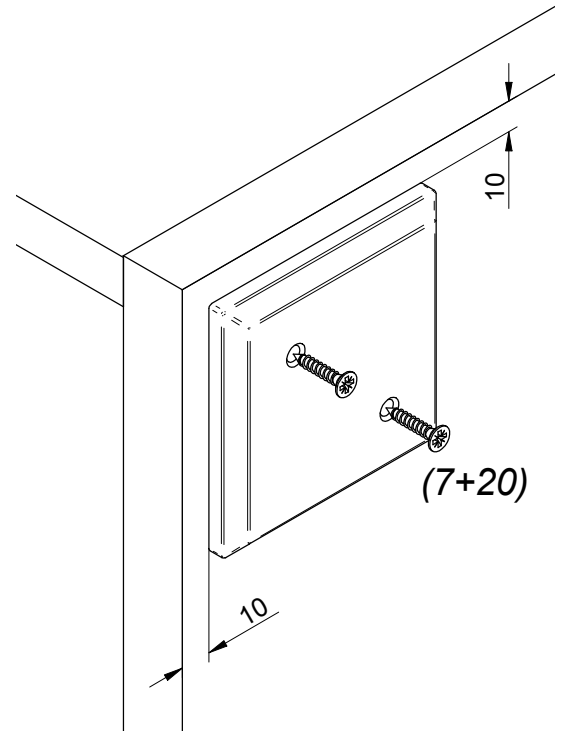
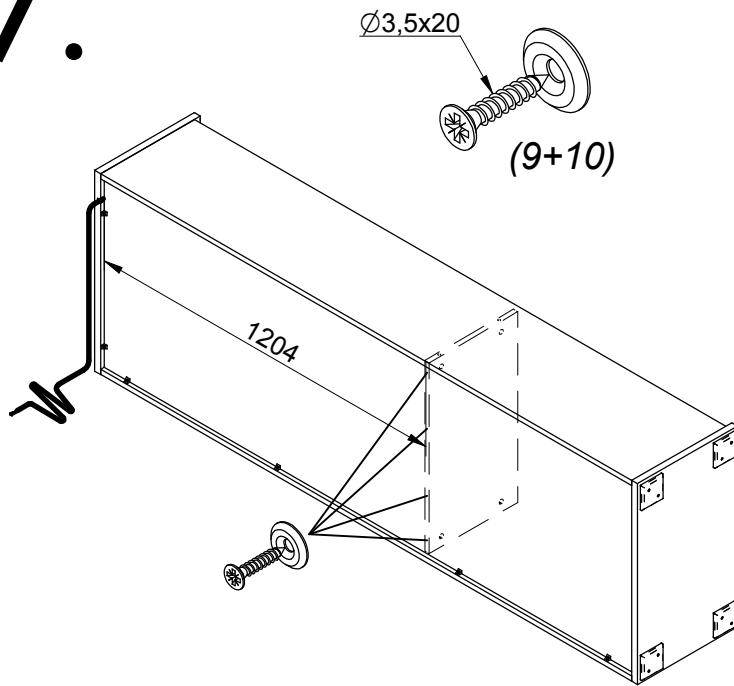

8.

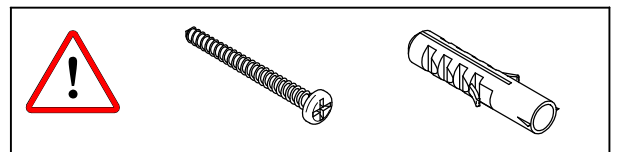
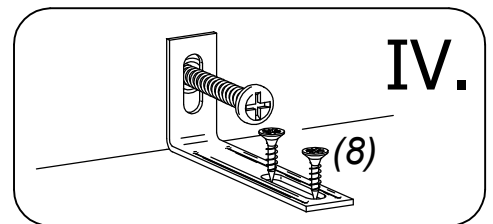
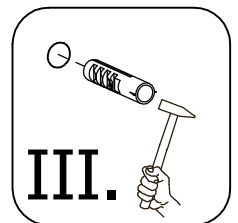
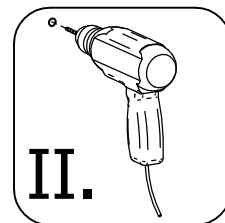
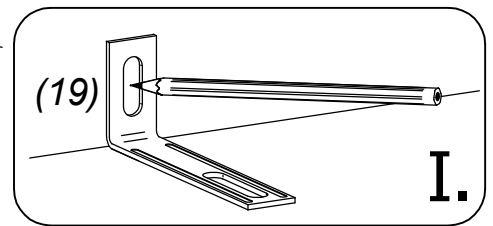
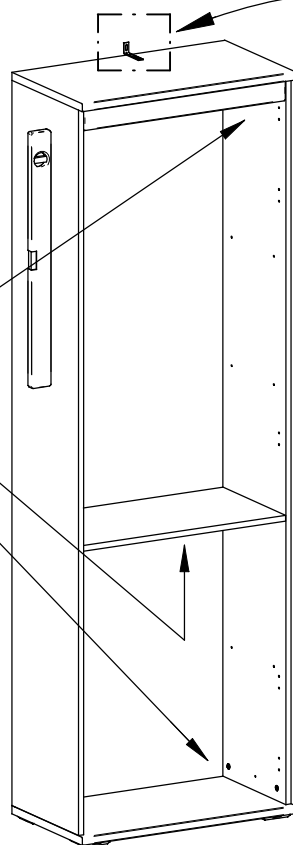
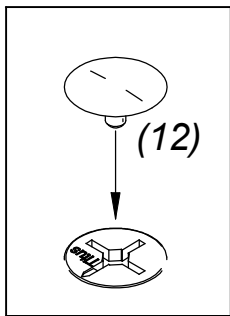

Wenn Möbelstücke umkippen, können ernste oder lebensgefährliche Verletzungen durch Einklemmen die Folge sein. Um zu verhindern, dass das Möbelstück umkippt, muss es fest an der Wand verankert werden. Beschläge für die Wandbefestigung sind nicht beige packt, da sie von der jeweiligen Wandbeschaffenheit abhängig sind. Befestigungsbeschläge benutzen, die für die heimischen Wände geeignet sind. Bei diesbezüglichen Fragen den örtlichen Fachhandel zu Rate ziehen.

Prevrhnutie nábytku môže spôsobiť vážne či smrteľné zranenia. Aby sa zabránilo prevrhnutiu nábytku, upevnite ho ku stene. Upevňovací materiál nie je súčasťou balenia, pretože na každý materiál steny je potrebné použiť iný typ skrutky a hmoždinky. Použite taký upevňovací materiál, ktorý je vhodný na konkrétny typ steny u vás doma. V prípade potreby sa poraďte s odborníkom.

9.

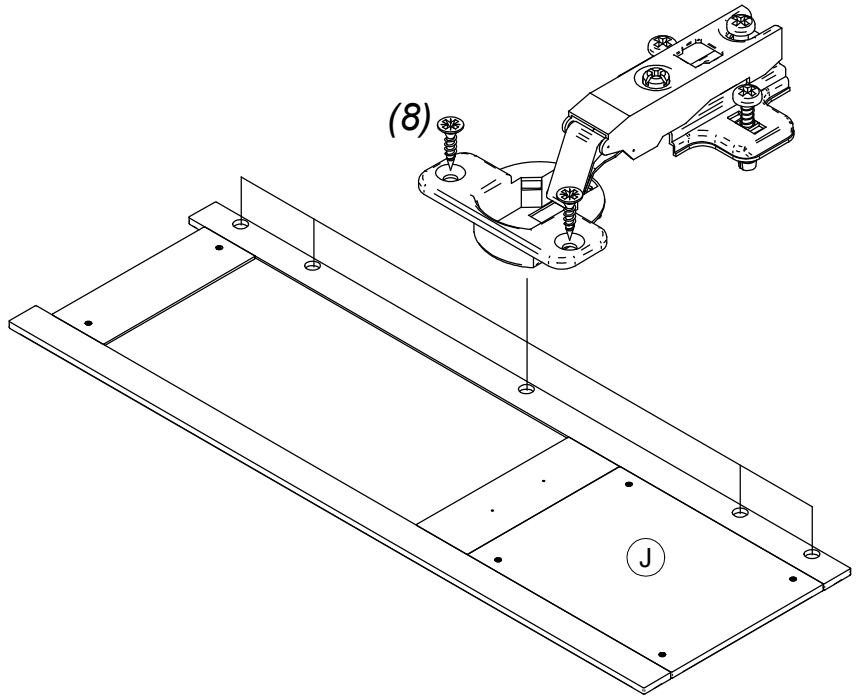
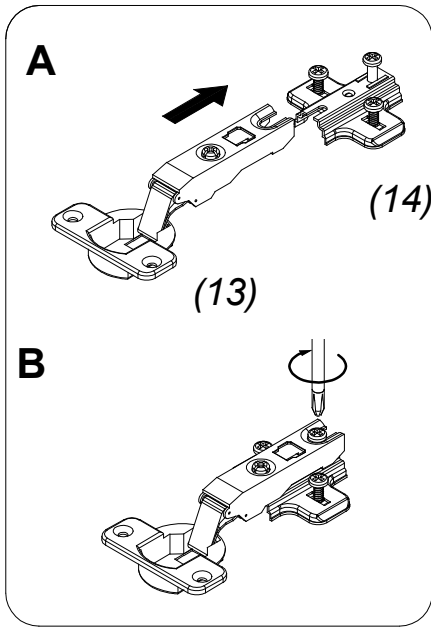

10.

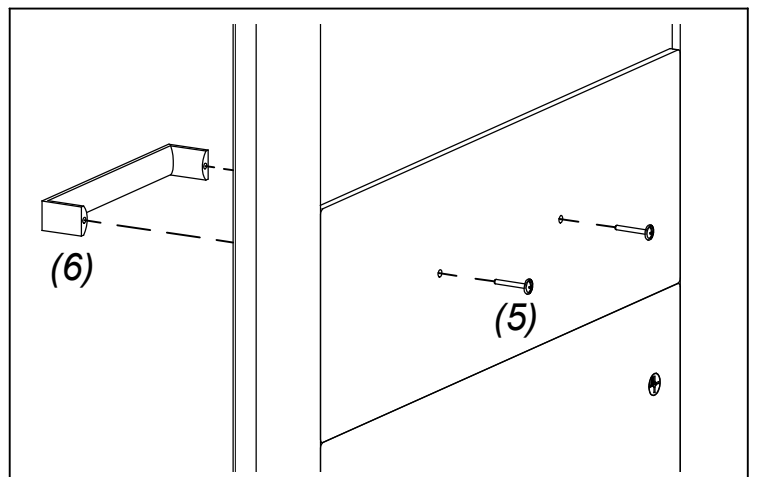
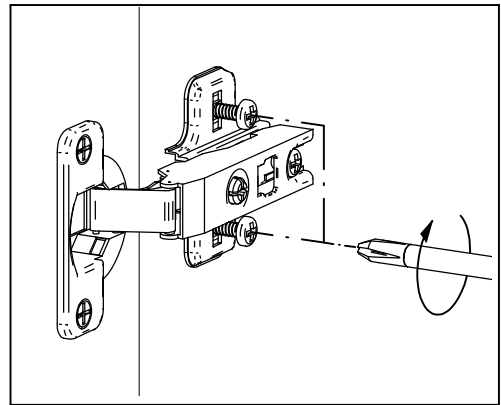
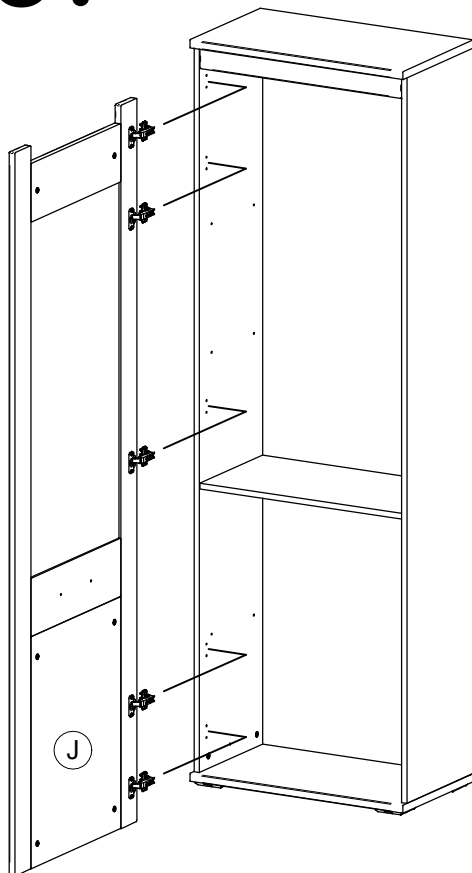

11.

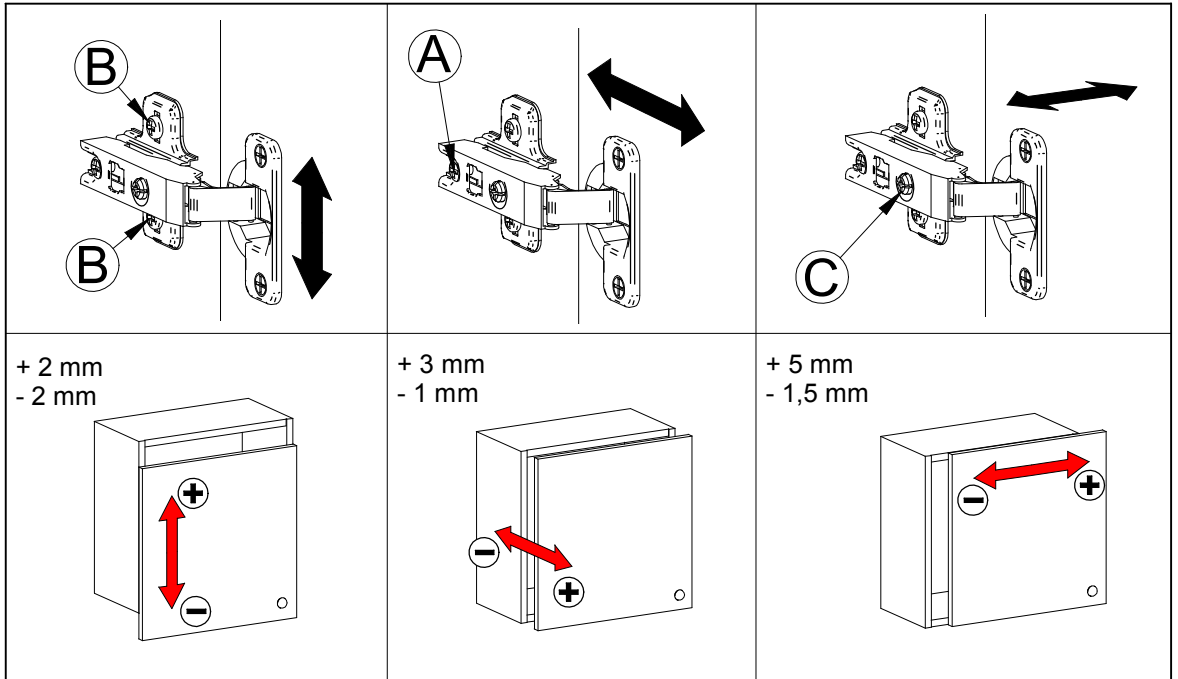

12.

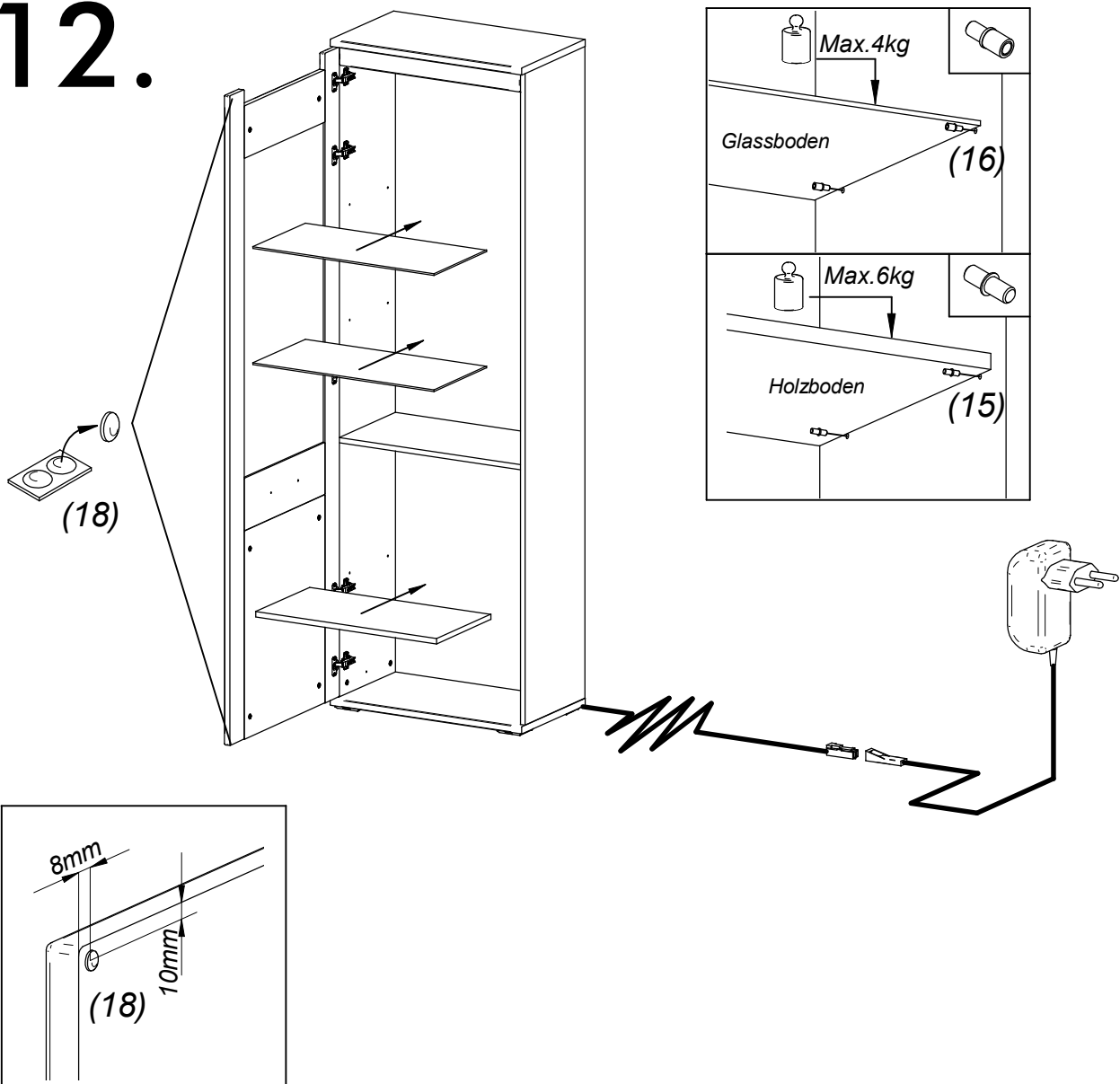

Montageanleitung / Montážny návod / Assembly instructions

MN 183/02
MN 185/02

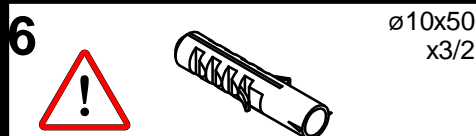
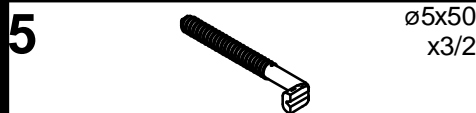
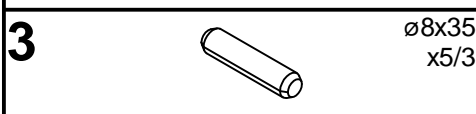
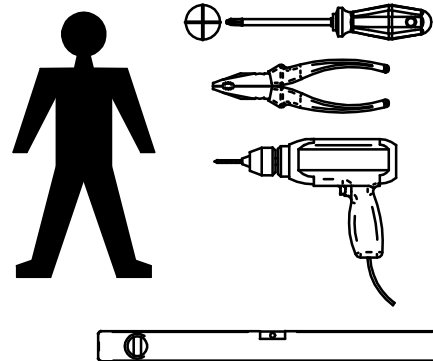
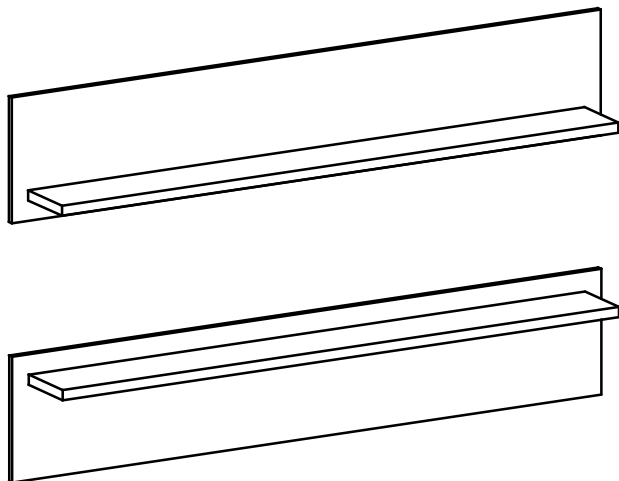

* NICHT BEINHALTET IM BESCHLAGBEUTEL!
* NIE JE SÚČASŤOU KOVANIA!



SERVICEKARTE / SERVISNÁ KARTA / SERVICE CARD

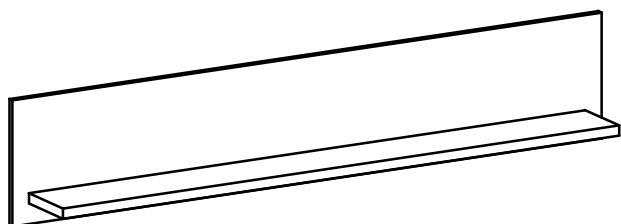
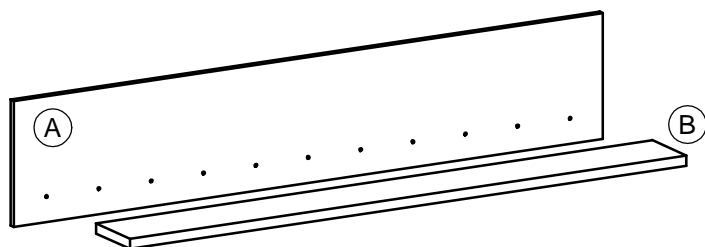

Alt.1

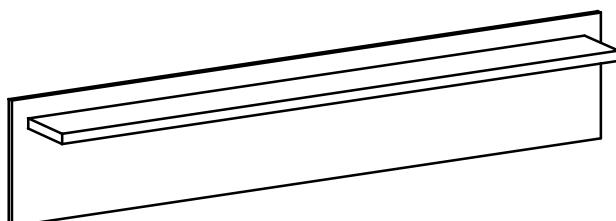

Alt.2

1.

Alt.1

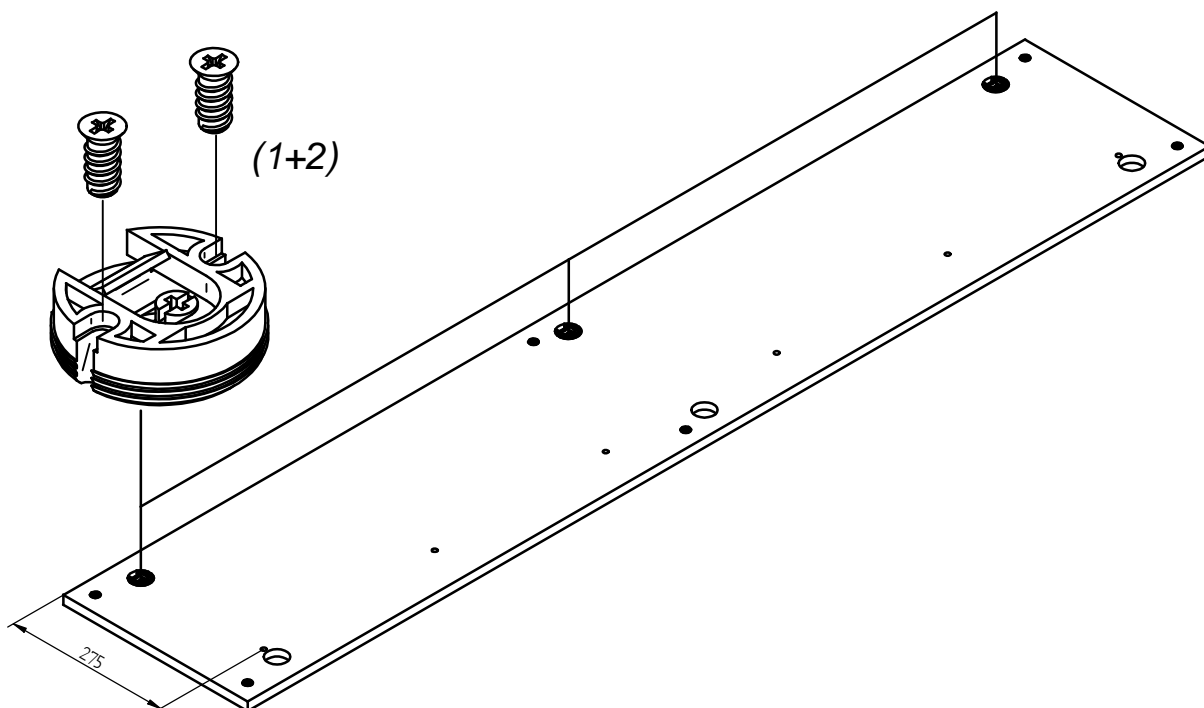

Alt.2

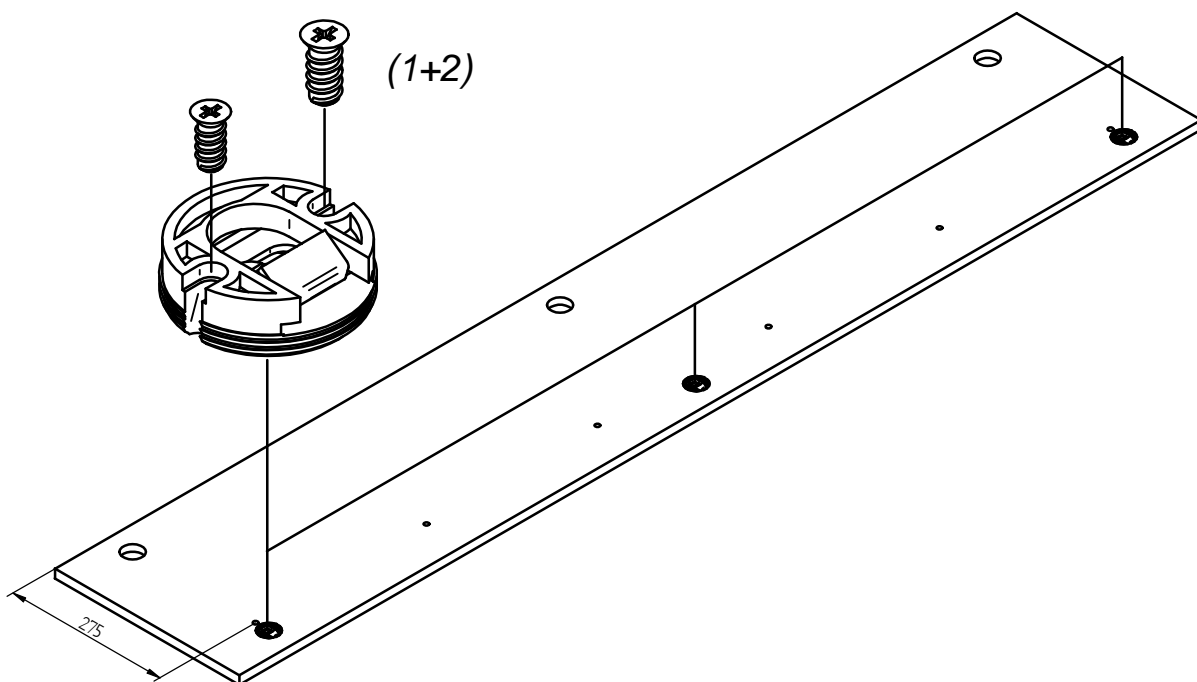

2.

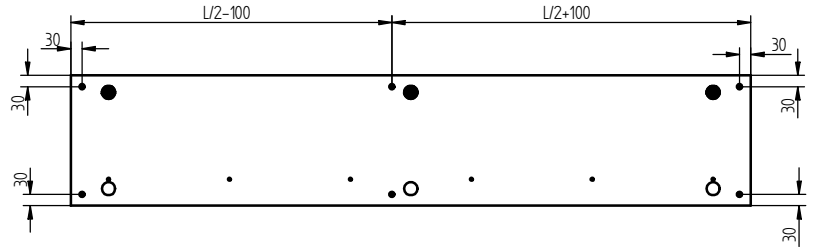
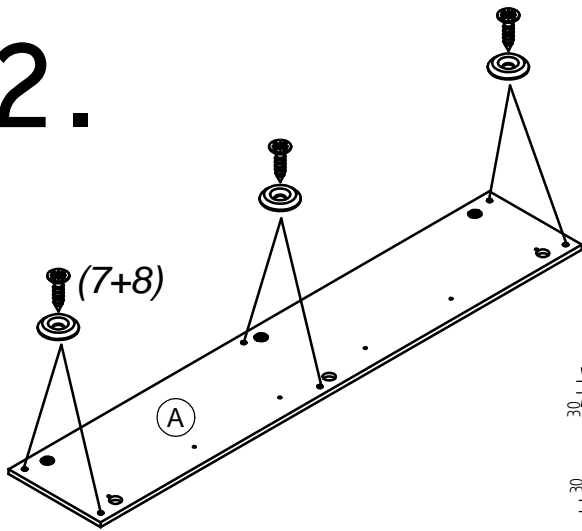

3.

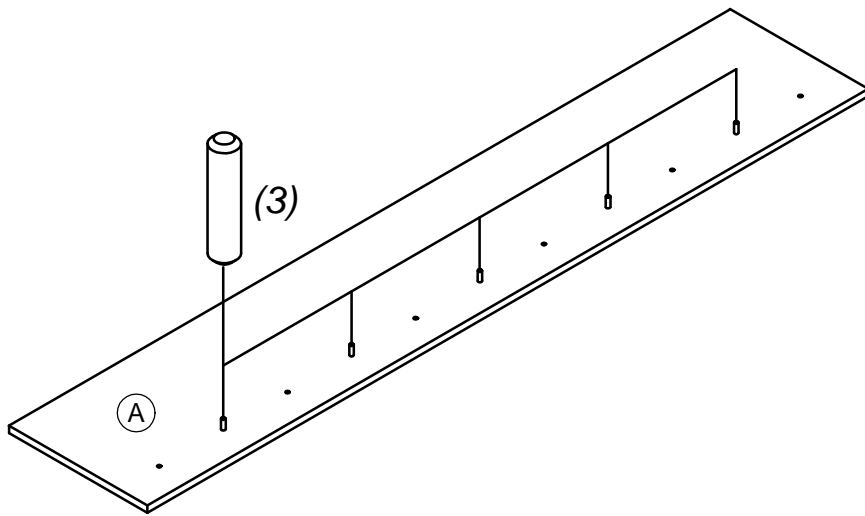

4.

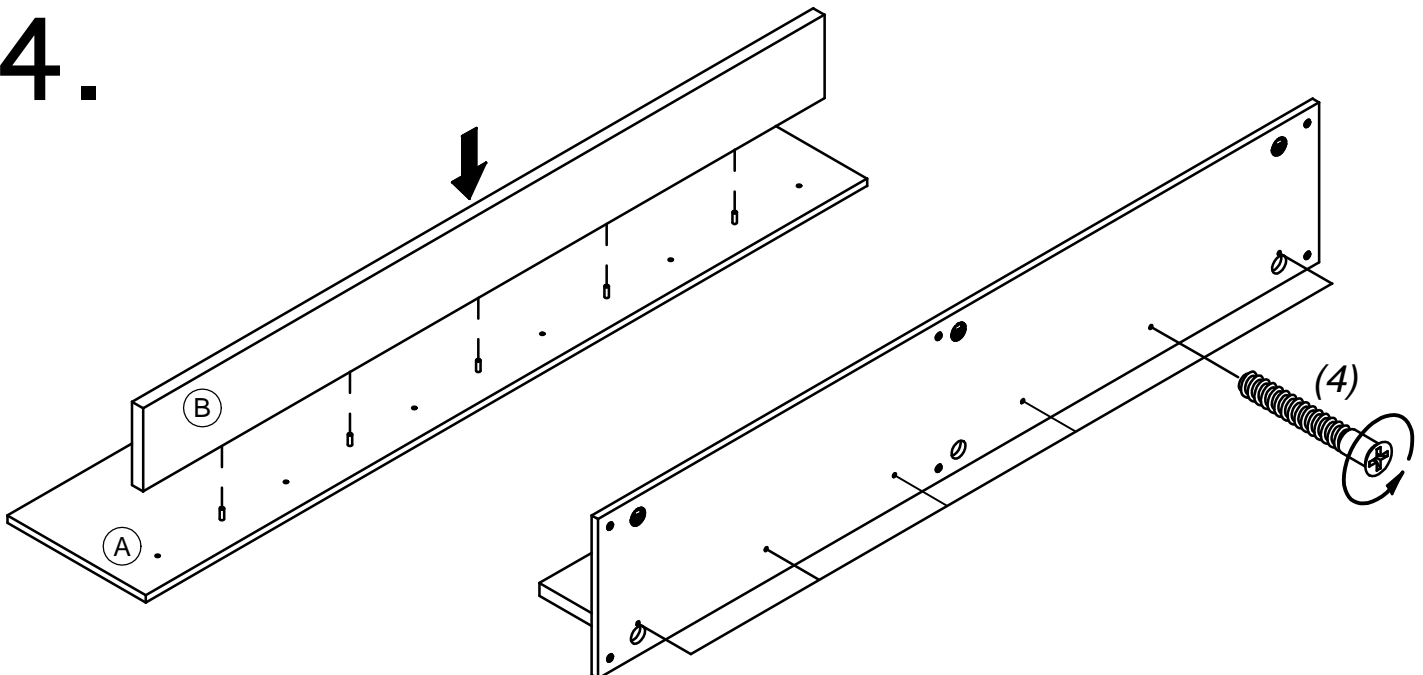

Achtung! Bitte nur Schraubenzieher zu verwenden, keinen Akkuschauber!

Pozor! Prosím skrutkujte manuálne, nie akuskrutkovačom.

Attention! Please, screw manually, dont use cordless screwdriver.



5.

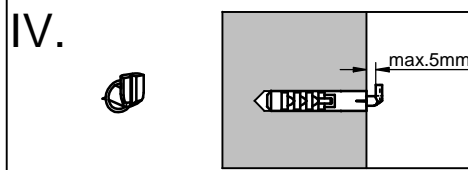
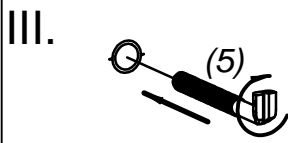
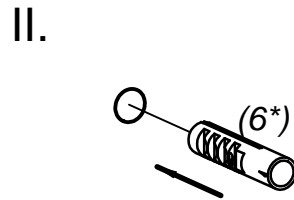
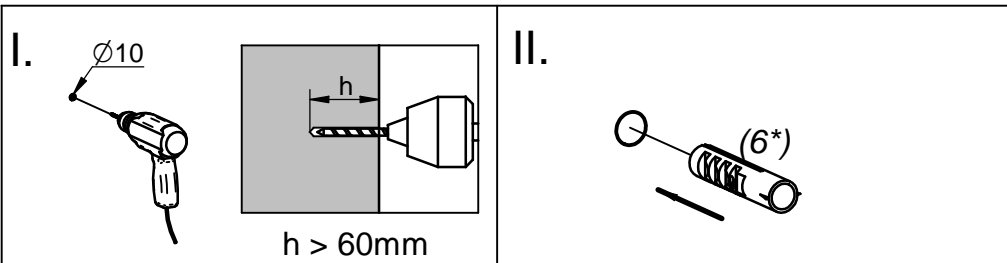

*Befestigungsdübel ist kein Bestandteil der Verpackung. Es ist nötig, einen geeigneten Dübel zu wählen, je nach der Tragfähigkeit und Zusammensetzung der Mauer, an die Schränke gehängt werden. Falls Sie sich nicht sicher sind, welcher Typ von Dübel Sie brauchen, nehmen Sie Kontakt mit dem nächsten Fachhandel auf.

*Upevňovacia hmoždinka nie je súčasťou balenia. Je nutné, zvoliť vhodnú hmoždinku vzhľadom na nosnosť a typ steny, na ktorú nábytok vešíate. Ak nie ste si istý, aký druh hmoždinky potrebujete, kontaktujte najbližšie železiarstvo.

Fixing dowel and screw are not included. Is necessary to choose suitable dowels and screws for wall, on which will be cabinets mounted (capacity and kind of wall). If you dont know which kind of screws or dowels do you need, contact your hardware store.

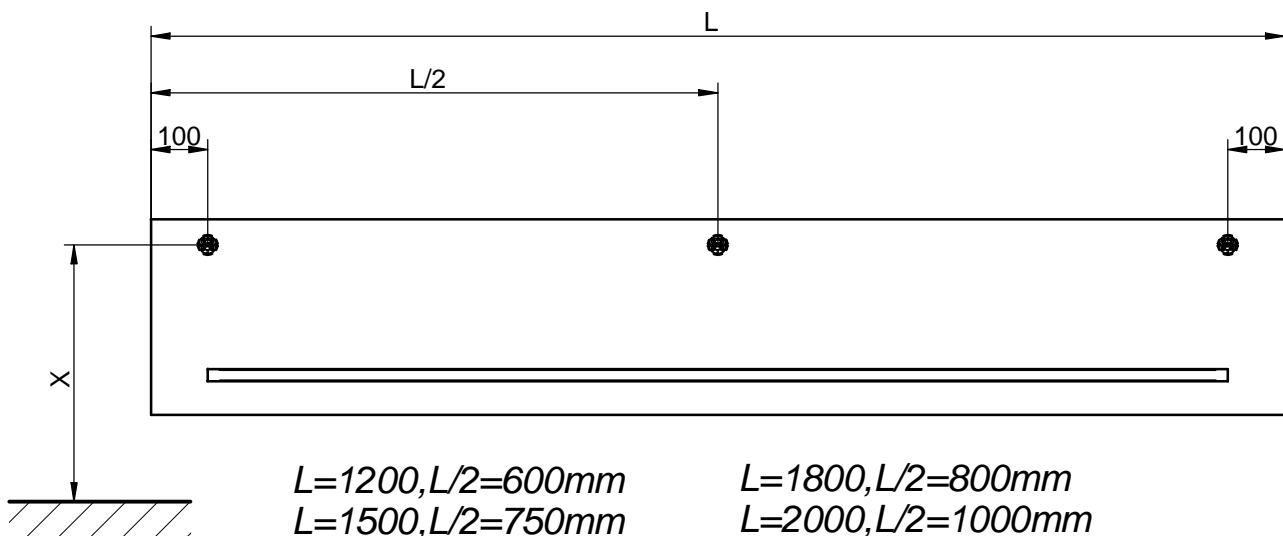
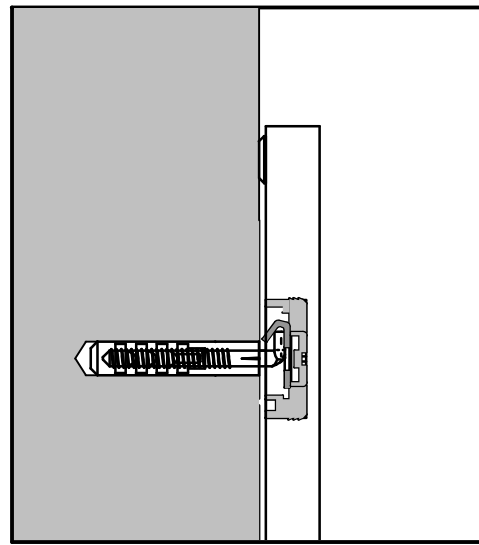
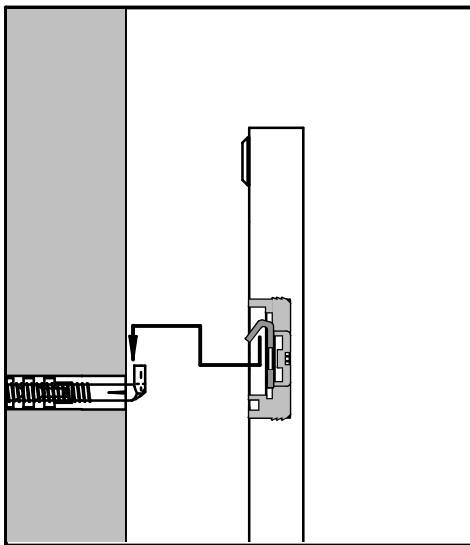

Aruba
 Kombi 23, X=1588mm
 Kombi 24, X=1588mm
 Kombi 33, X=1697mm
 Kombi 35, X=1588mm
 Kombi 81, X=1588mm

Boa
 Kombi 34, X=1762mm
 Kombi 35, X=1762mm
 Kombi 36, X=1894mm

Verona
 Kombi 01, X=1650mm
 Kombi 02, X=1650mm
 Kombi 03, X=1900mm

Benó
 Kombi 11, X=1820mm
 Kombi 12, X=1730mm

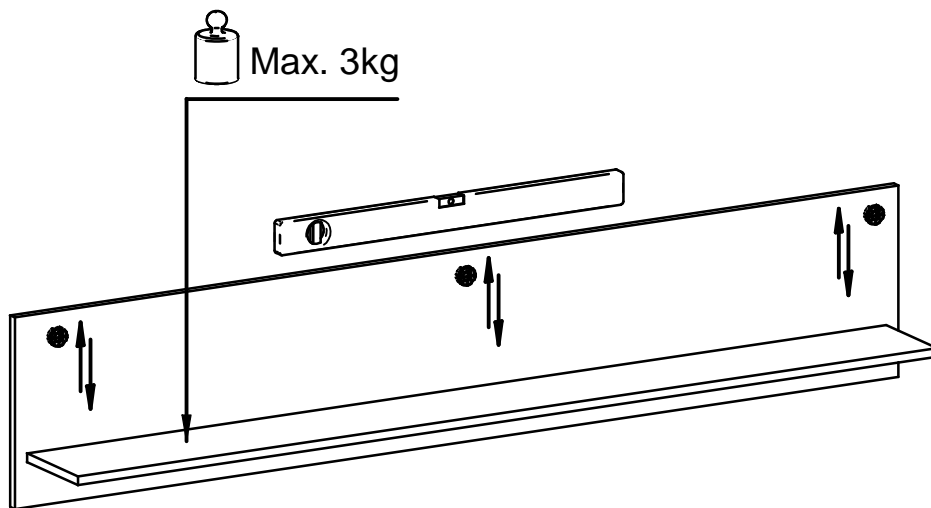
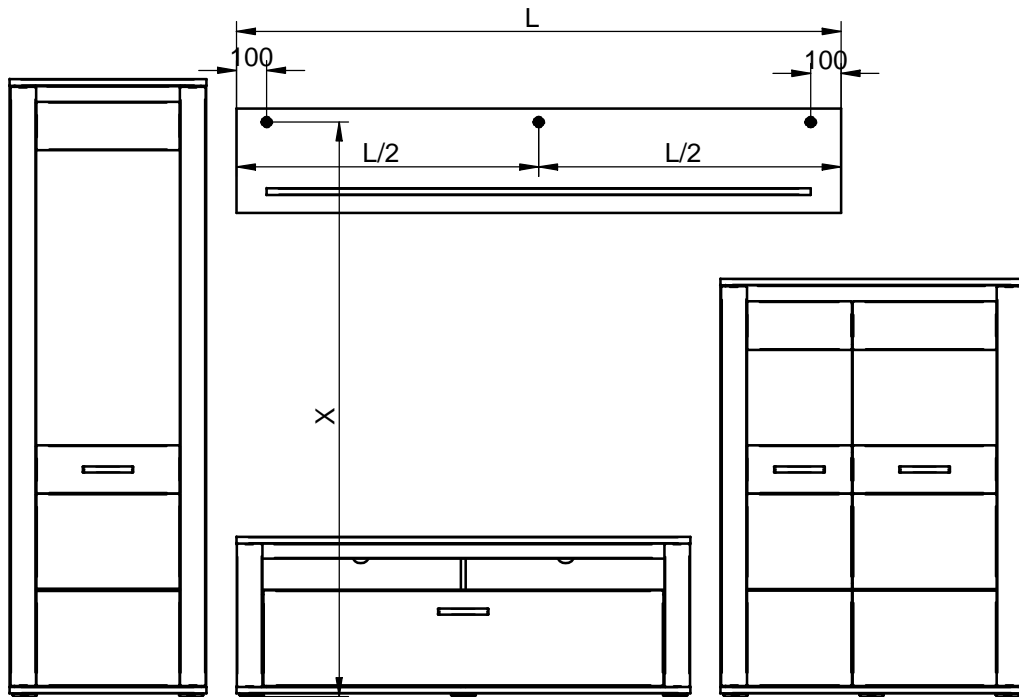



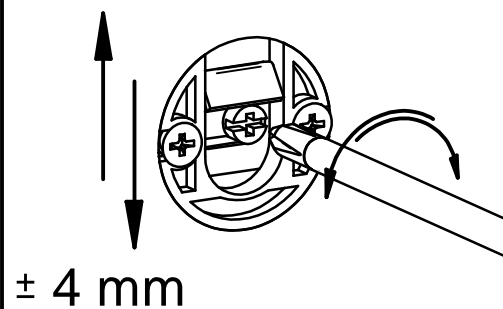



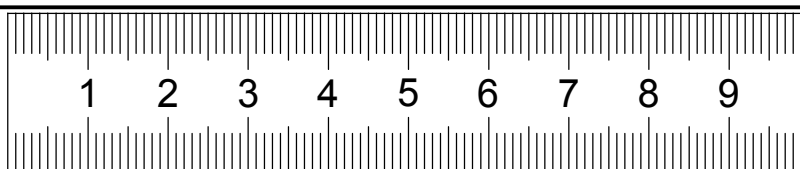
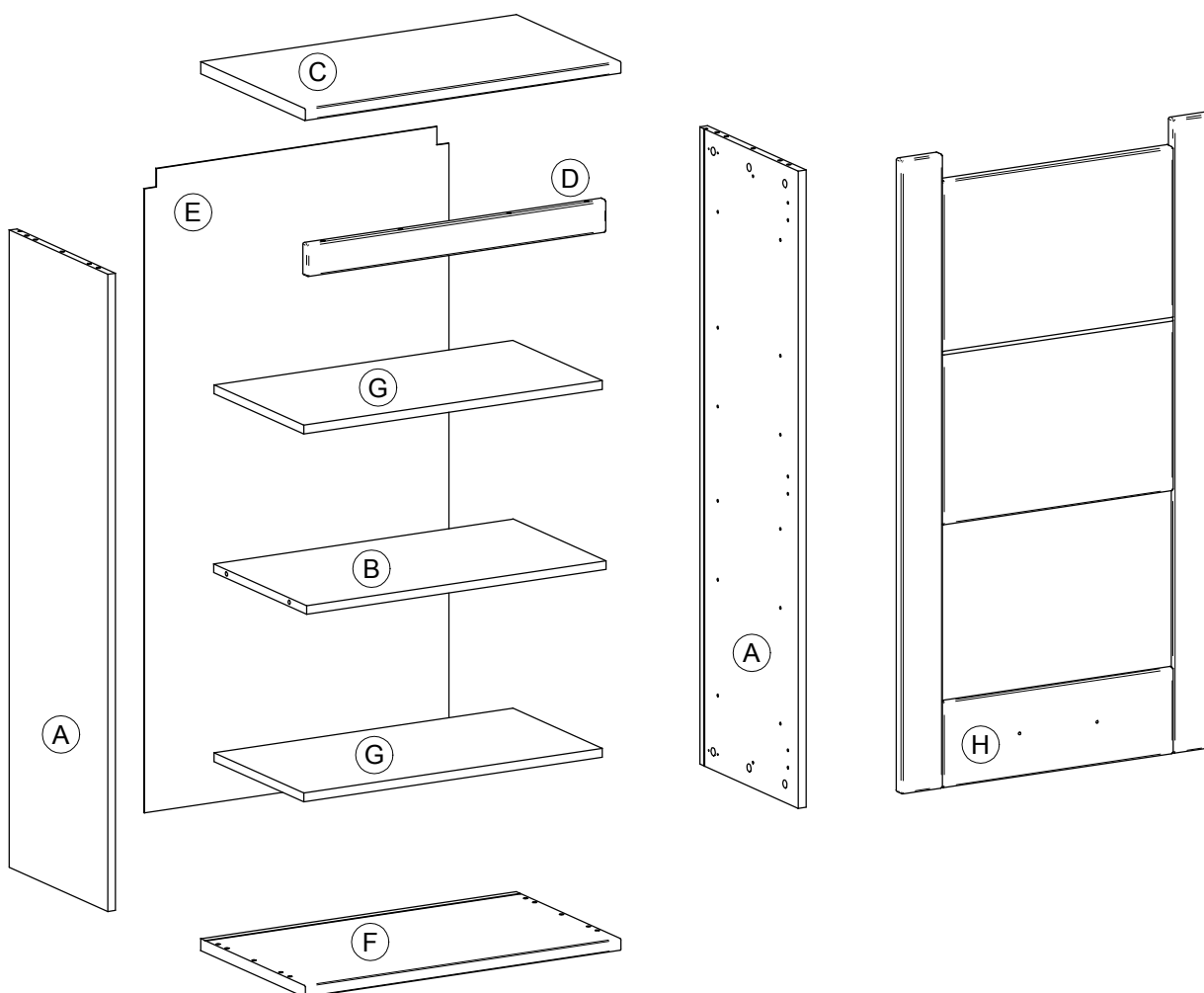
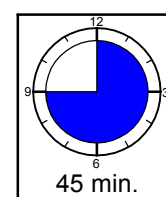
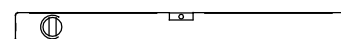
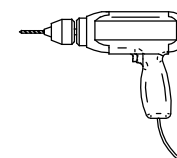
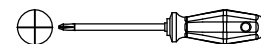
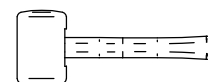
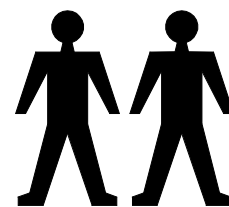
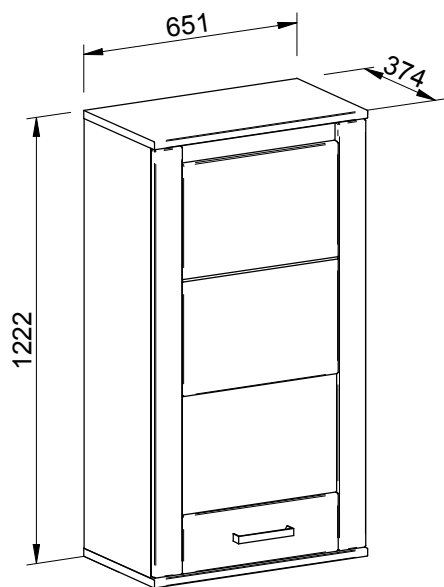

Höheneinstellung /
výškové nastavenie

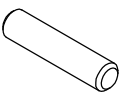
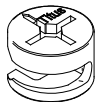
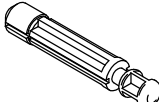
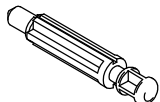
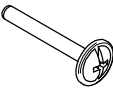
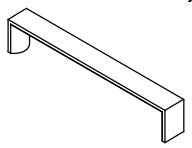
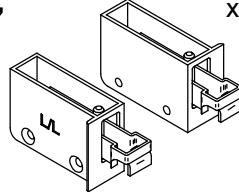

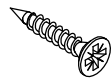
height adjustment

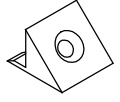
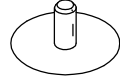
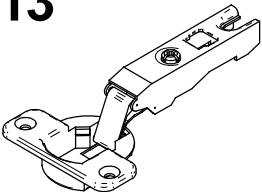
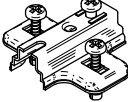
VERONA 22

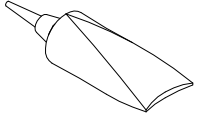
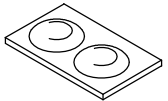
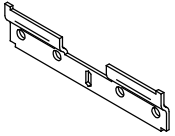

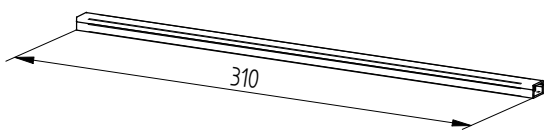
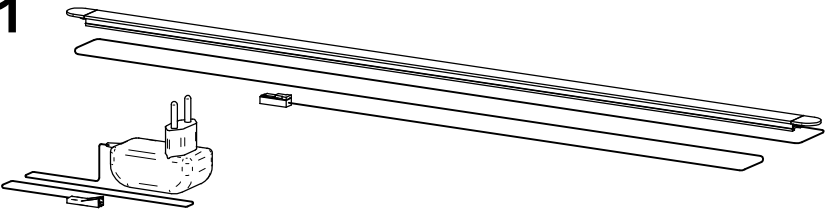
1 $\varnothing 8 \times 35$ x12 	2 $\varnothing 15$ x16 	3 $\varnothing 8$ x12 	4 $\varnothing 5$ x4 	5 $\varnothing 4 \times 25$ x2 
6 x1 	7 x1 	8 $\varnothing 3,5 \times 15$ x6 	9 $\varnothing 3,5 \times 20$ x14 	10 $\varnothing 12$ x4 
11 x10 	12 $\varnothing 15$ x16 	13 x3 	14 x3 	15 $\varnothing 5$ x8 
16 x1  <p>Vor Gebrauch schütteln Shake before use Pred použitím zatrepáť</p>	17 x2 	18 x1 	19 $\varnothing 4 \times 30$ x4 	
20 		21 		

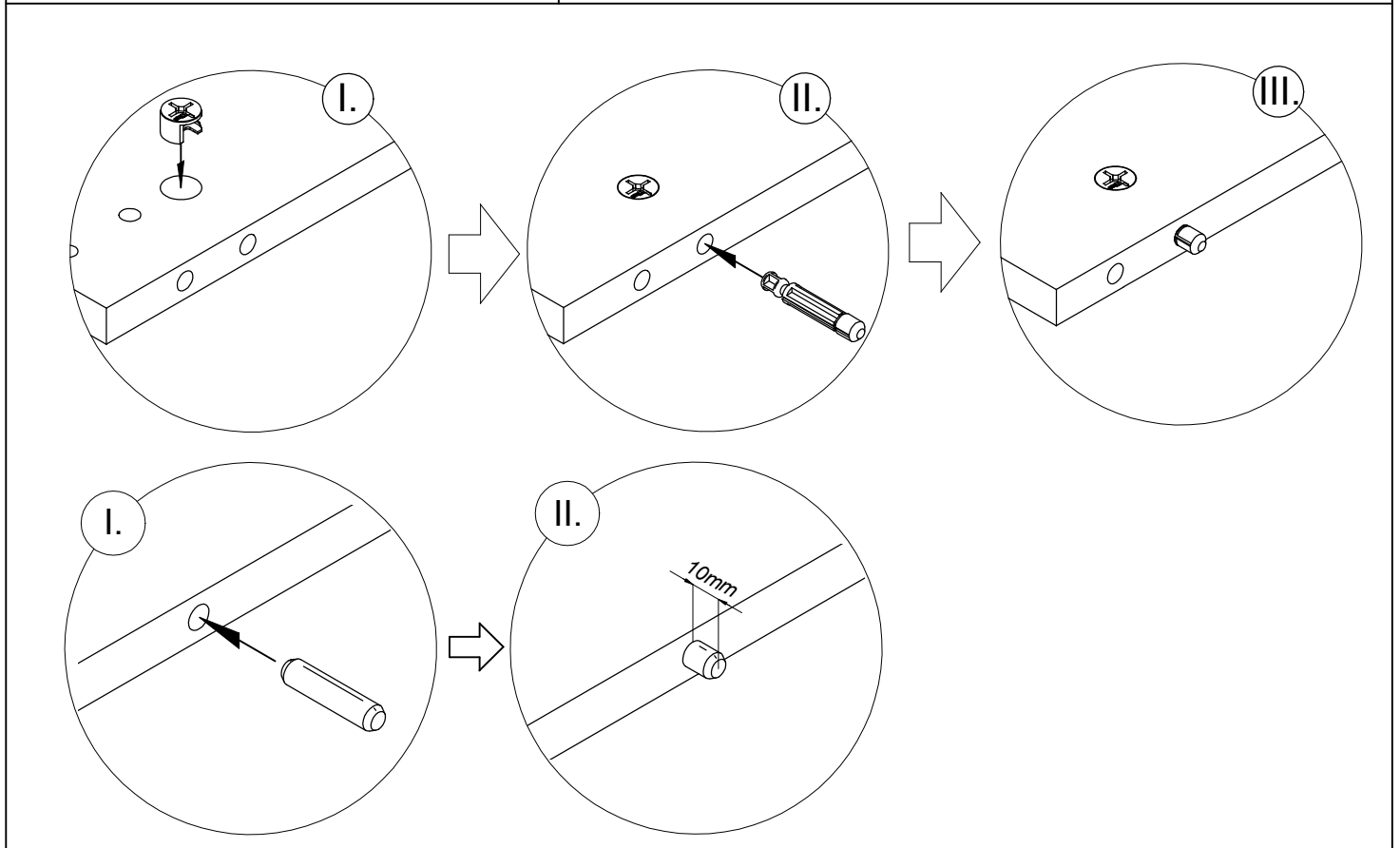

1.

1.1

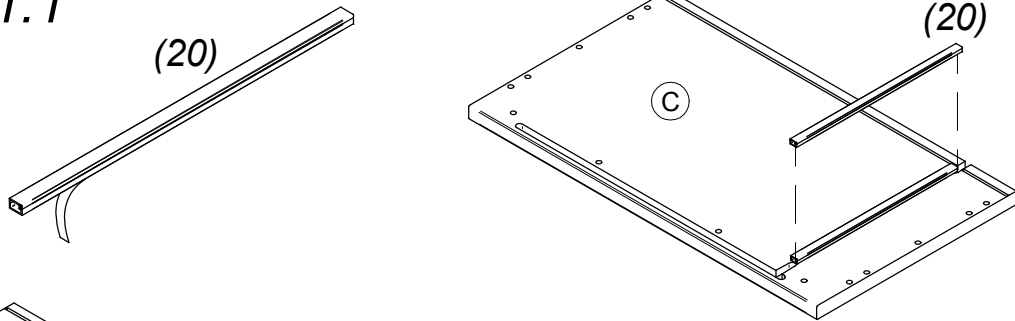

1.2

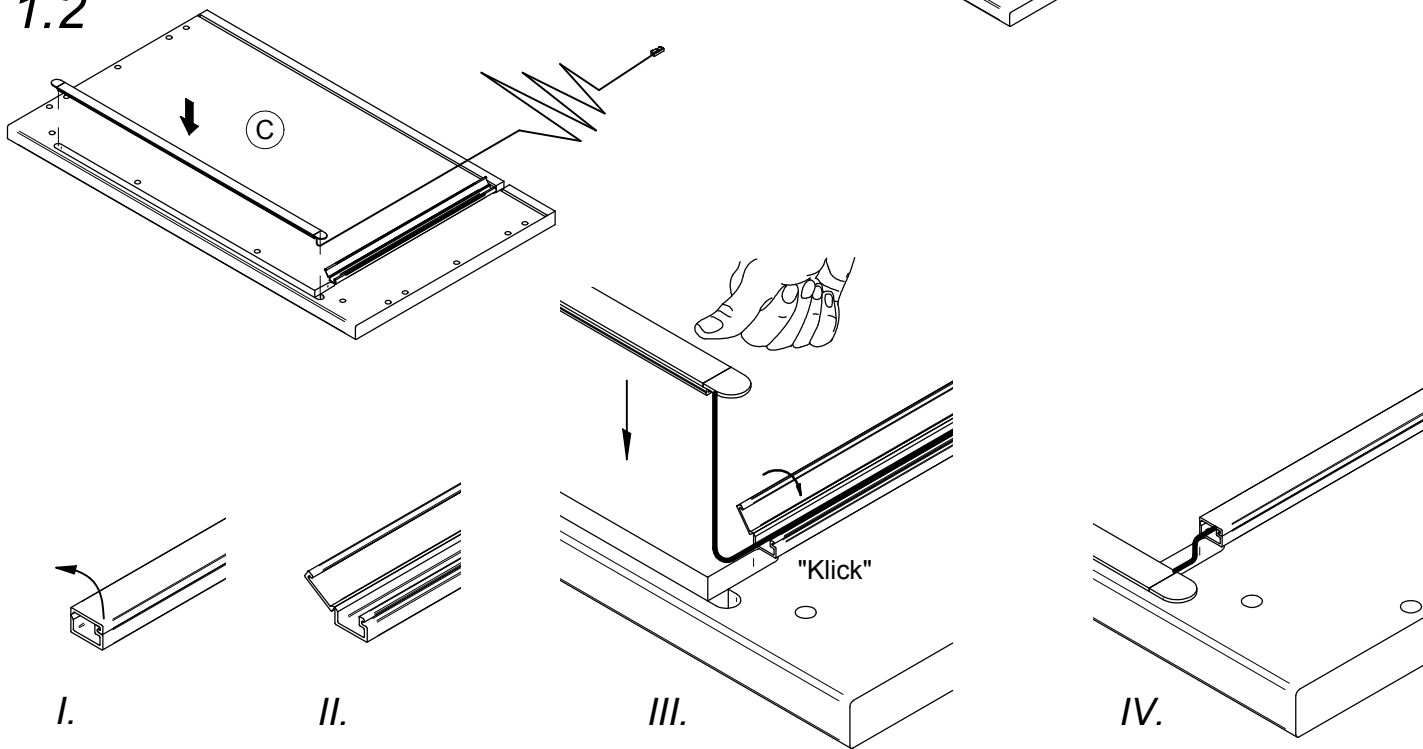

1.3

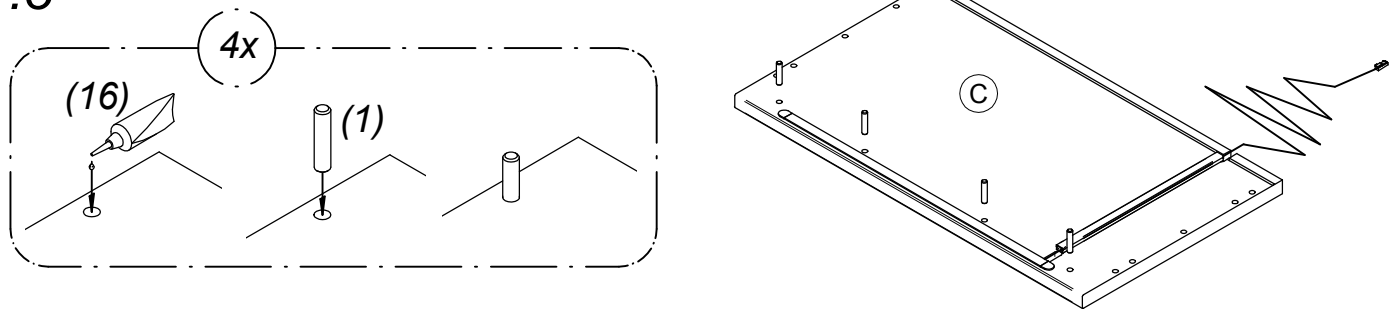

1.4

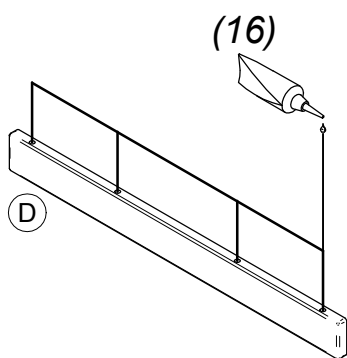

1.5

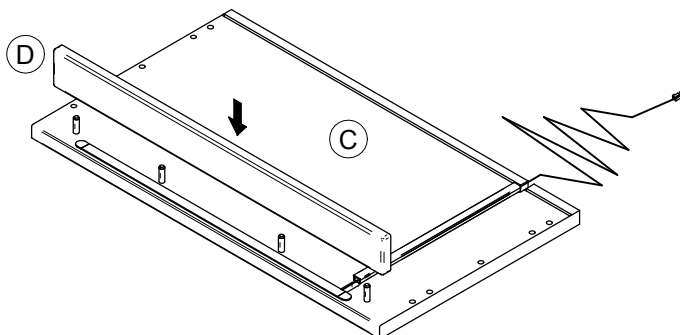

2.

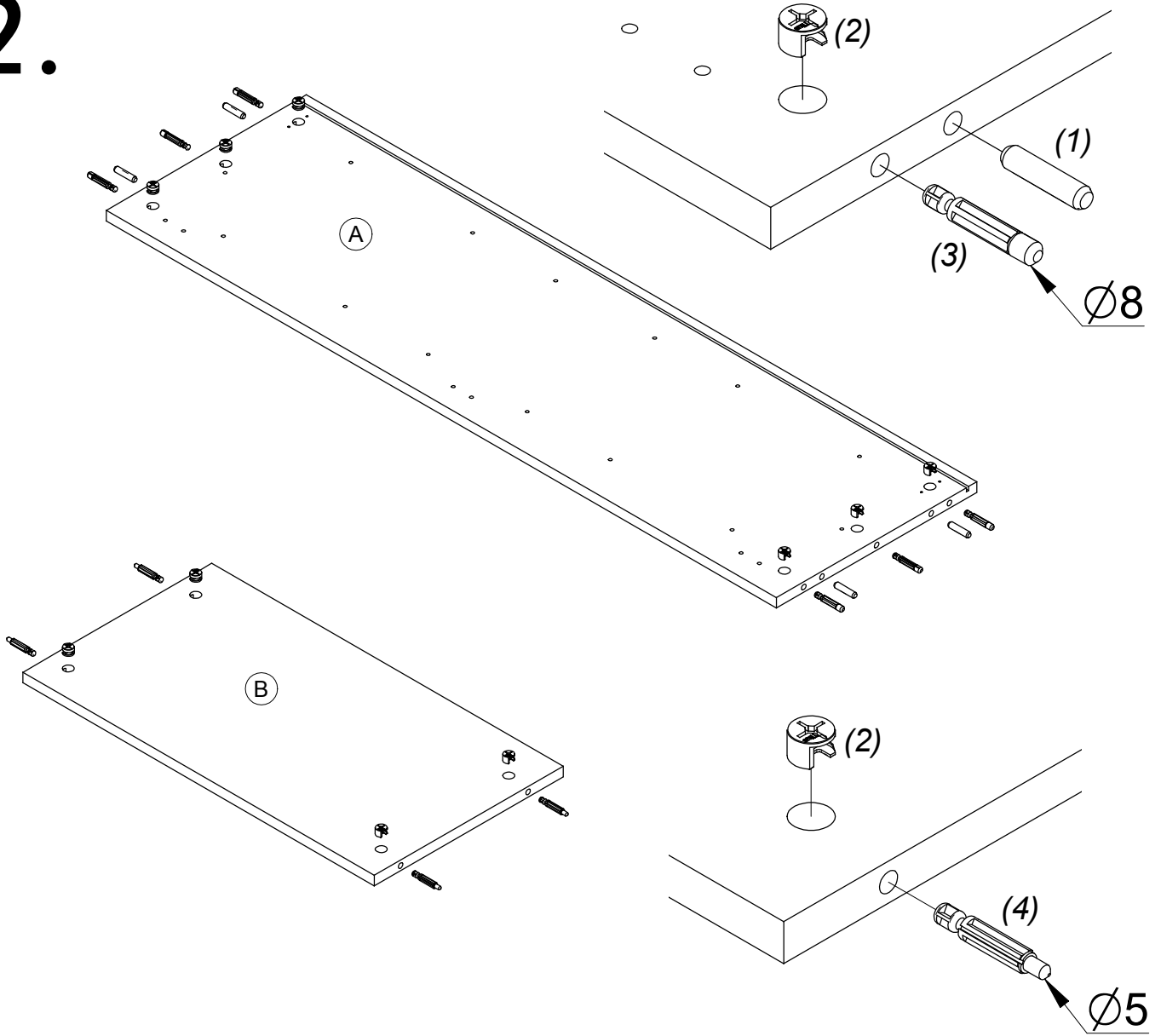

3.

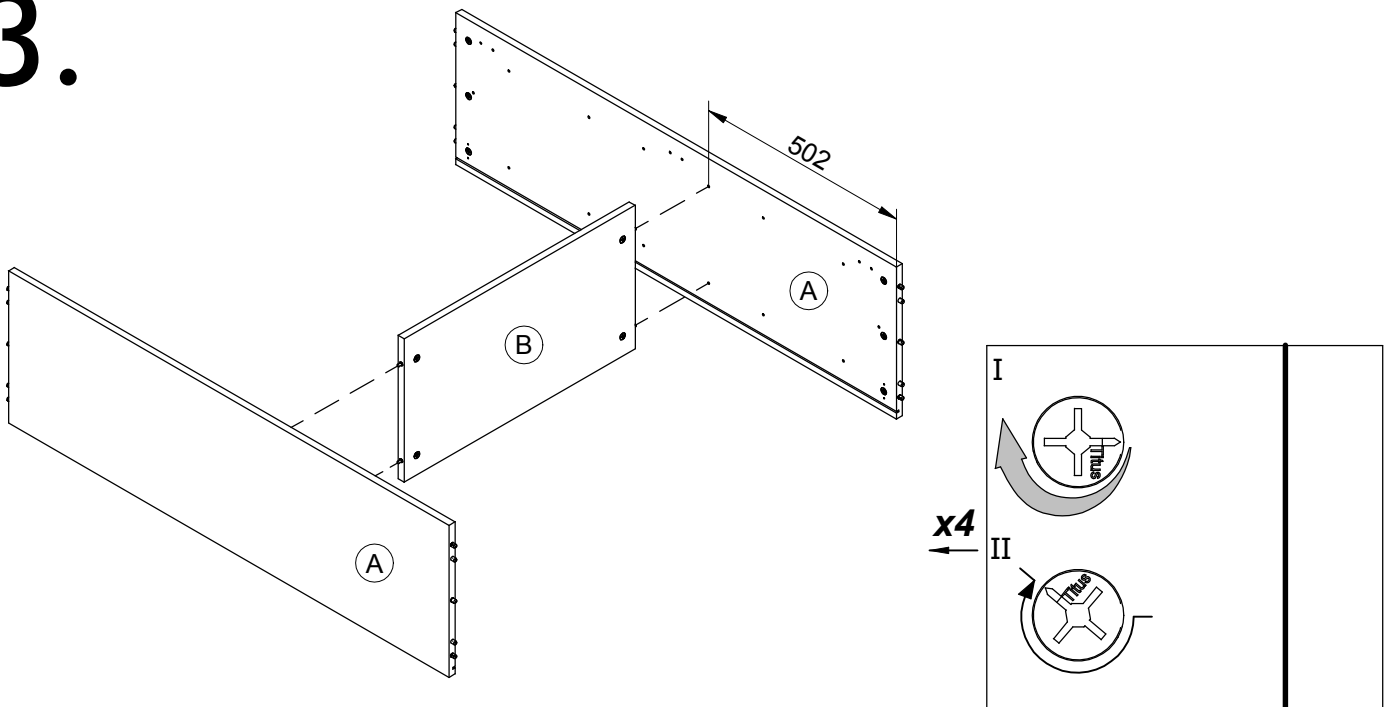

4.

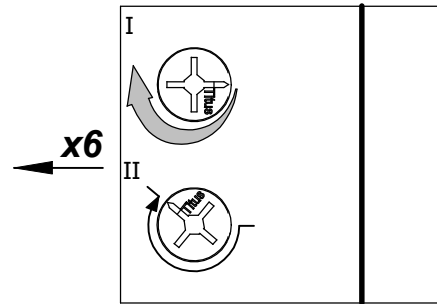
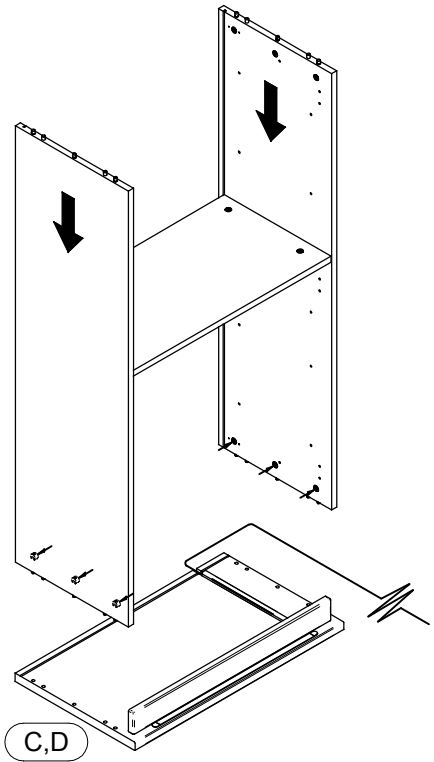

5.

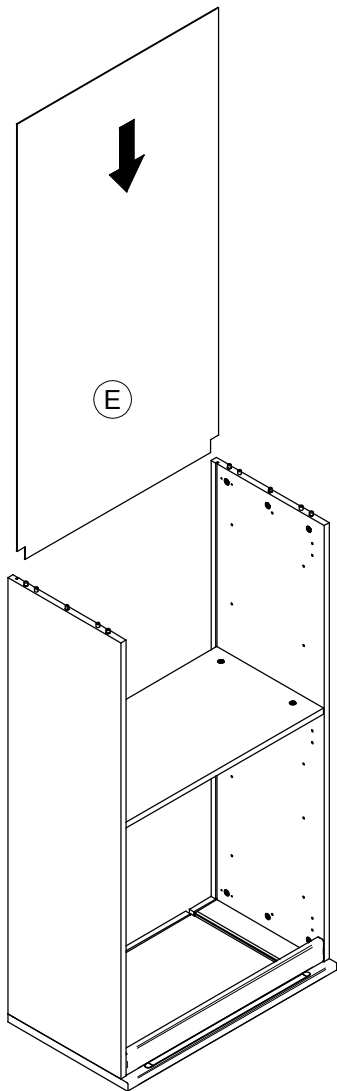

6.

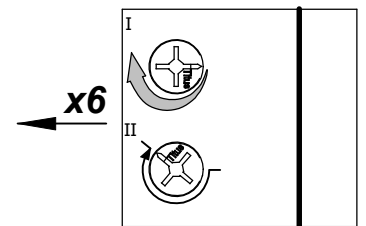
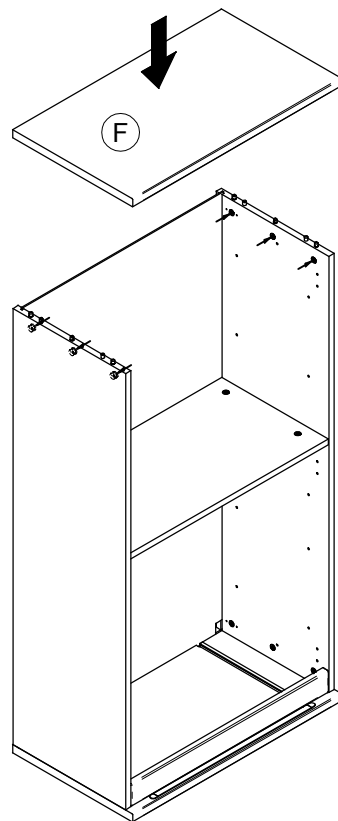

7.

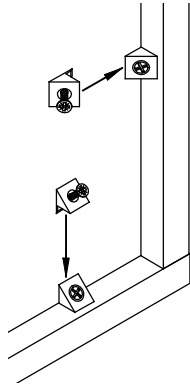
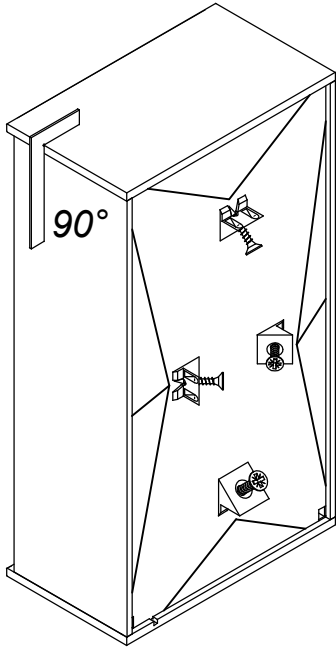
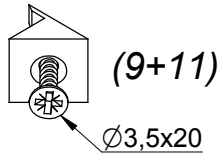

8.

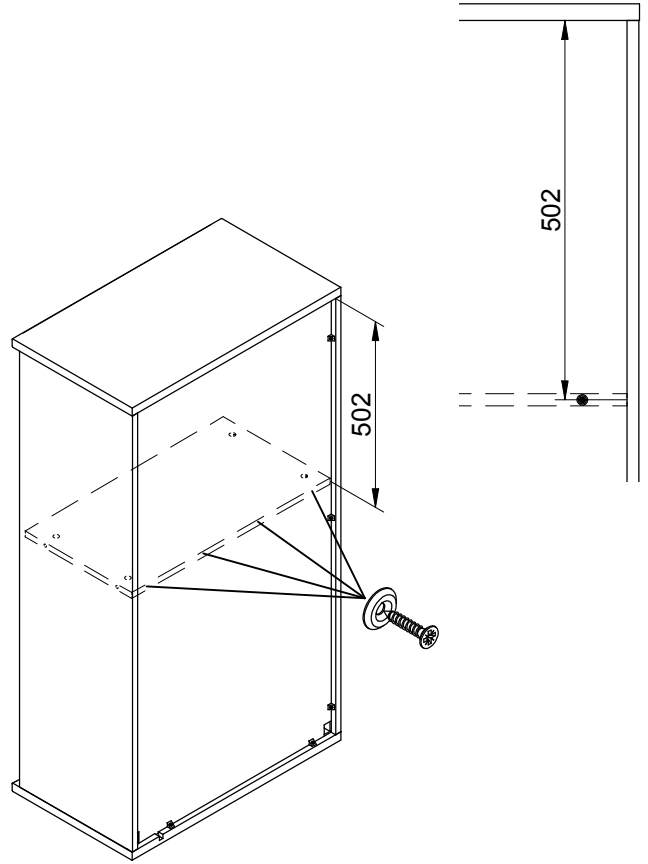
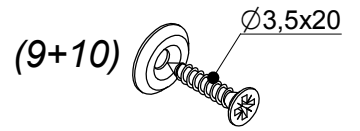

9.

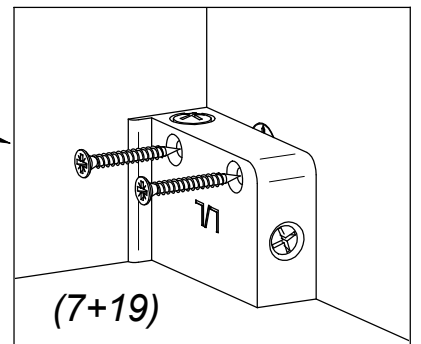
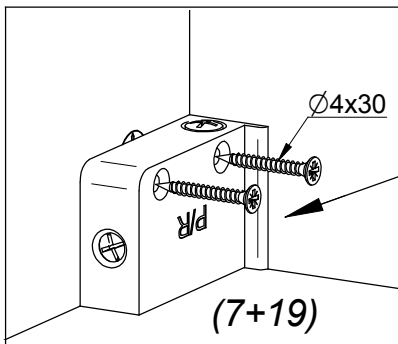
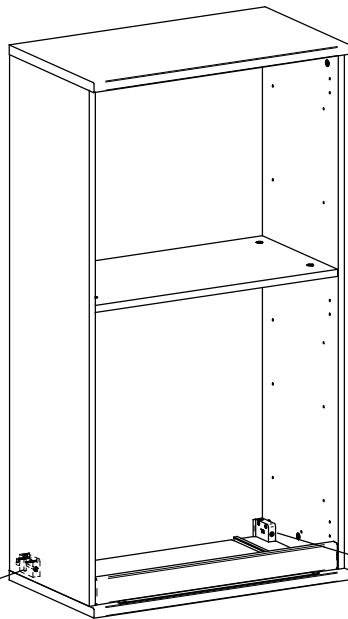

10.

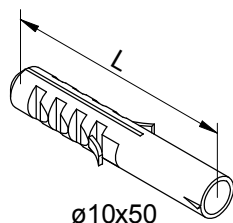
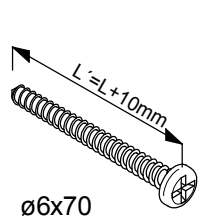
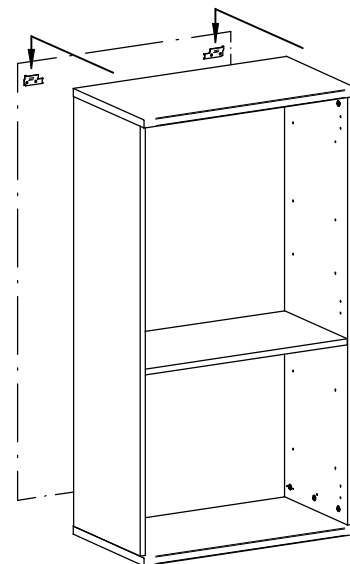
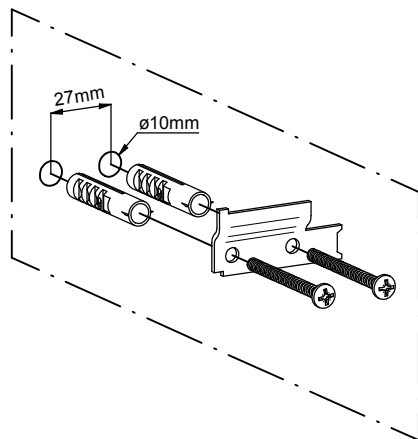
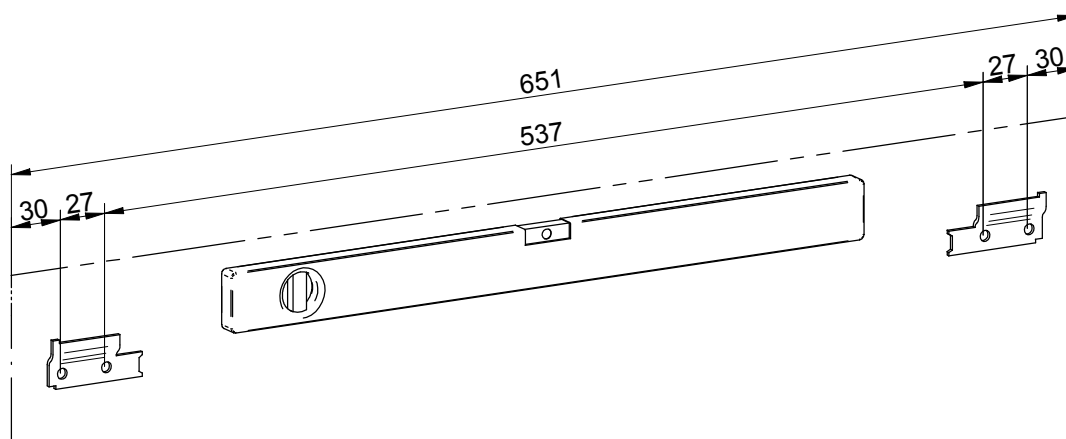
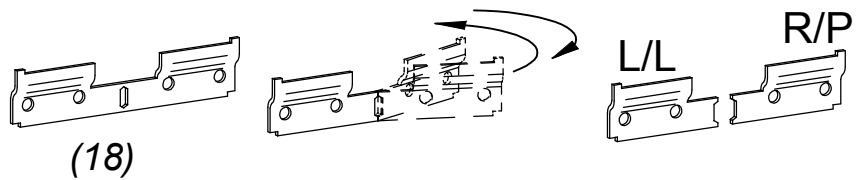

* Befestigungsdübel und Schraube sind kein Bestandteil der Verpackung. Es ist nötig, einen geeigneten Dübel und Schrauben zu wählen, je nach der Tragfähigkeit und Zusammensetzung der Mauer, an die Schränke gehängt werden. Falls Sie sich nicht sicher sind, welcher Typ von Dübel und Schrauben Sie brauchen, nehmen Sie Kontakt mit dem nächsten Fachhandel auf.

* Upevňovacia hmoždinka a skrutka nie sú súčasťou balenia. Je nutné, zvoliť vhodnú hmoždinku a skrutku vzhľadom na nosnosť a typ steny, na ktorú nábytok vešiате. Ak nie ste si istý, aký druh hmoždinky a skrutky potrebujete, kontaktujte najbližšie železiarstvo.

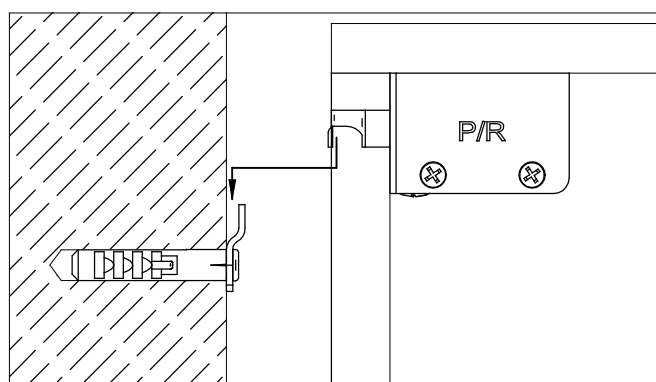
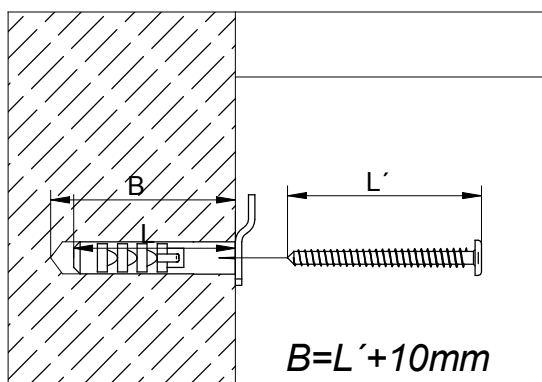

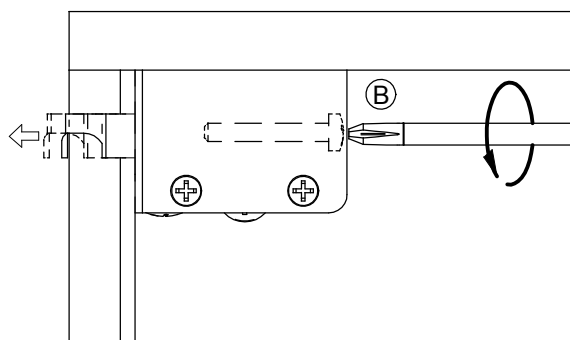
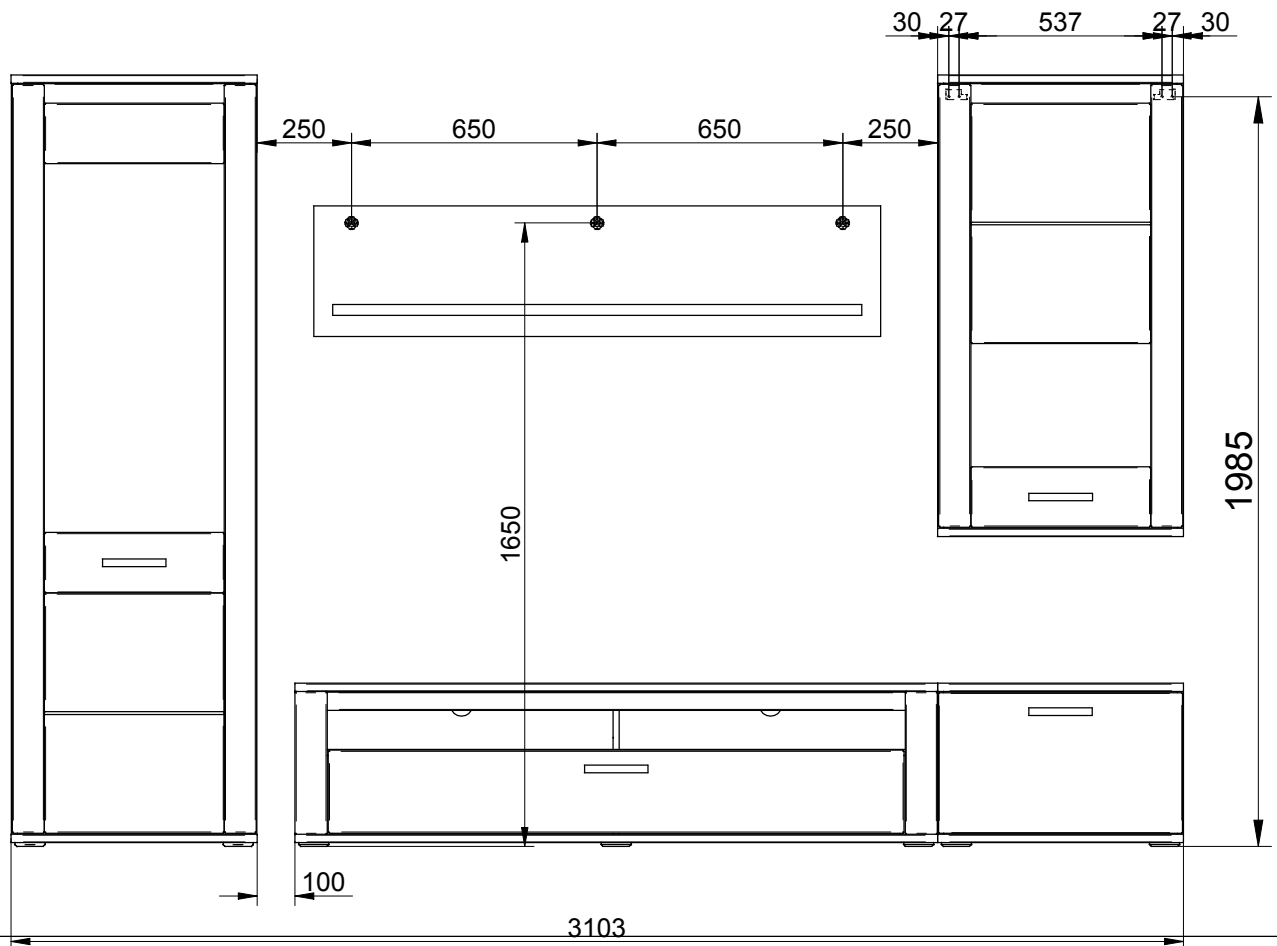

Vergessen Sie sich, ob der Schrank sicher aufgehängt ist!
Beim Einstellen muss der Schrank auf das Drehen der Schrauben A,B reagieren.
Falls Sie nicht sicher sind, dass der Schrank korrekt aufgehängt ist :

1. hängen Sie den Schrank herab
2. lösen Sie die Schraube B um einige Umdrehungen gegen Uhrzeigersinn (damit nird der Hängehaken in der Richtung aus dem Schrank mehr vorgeschoben)
3. probieren Sie den Schrank wieder korrekt aufhängen

Preverte si, že skrinka je bezpečne zavesená!
Počas nastavovania, skrinka musí reagovať na otáčanie skrutiek A,B.
Ak nie ste si istí, že je skrinka správne zavesená :

1. zveste skrinku zo steny
2. povoľte skrutku B o niekoľko otáčok proti smeru hodinových ručičiek (vysuniete tým závesný hák smerom viac zo skrinky)
3. pokúste sa znova skrinku správne zavesiť



Nach definitivem Einstellen ziehen Sie langsam den Schrank zur Wand mit der Schraube B.

Po definitívnom nastavení, pomaly pritiahnite skrutkou B skrinku k stene.

11.

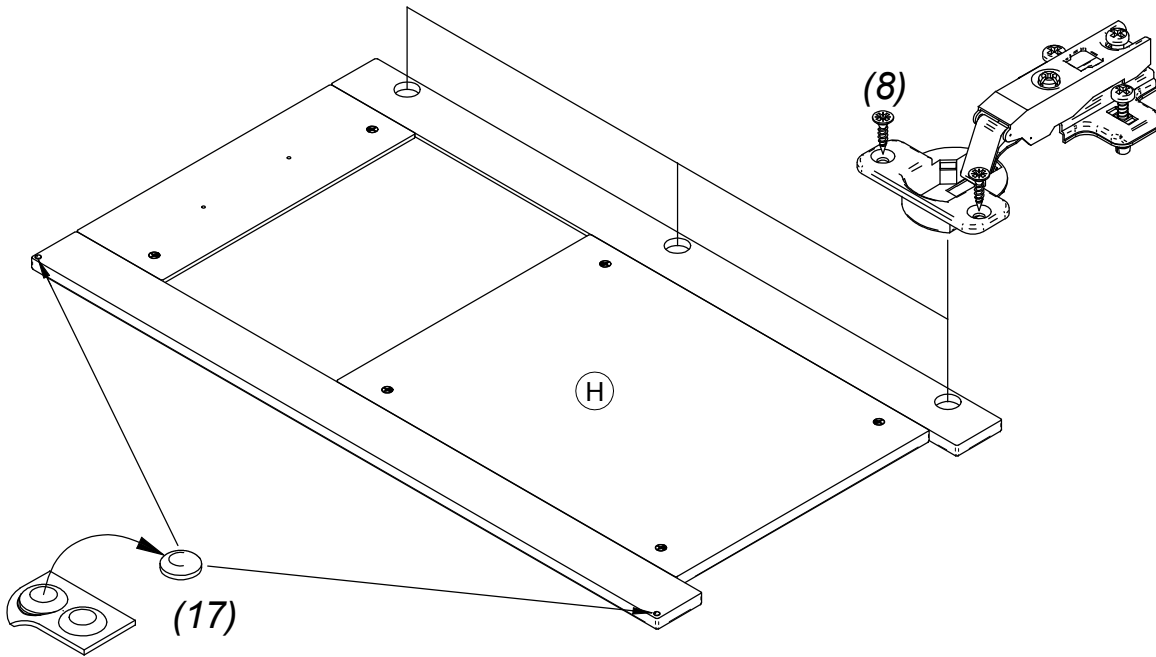
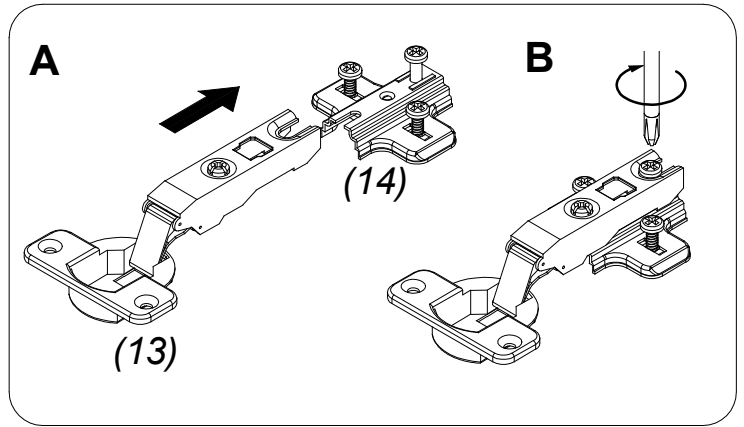

12.

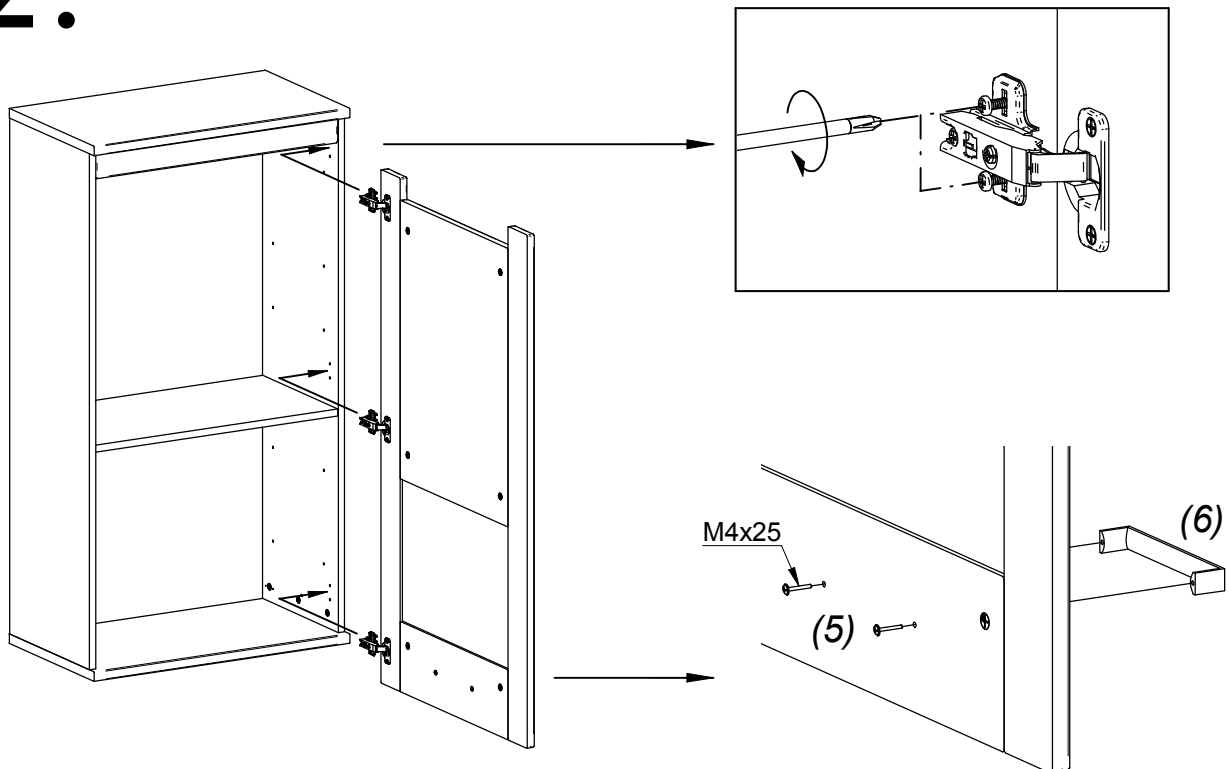

13.

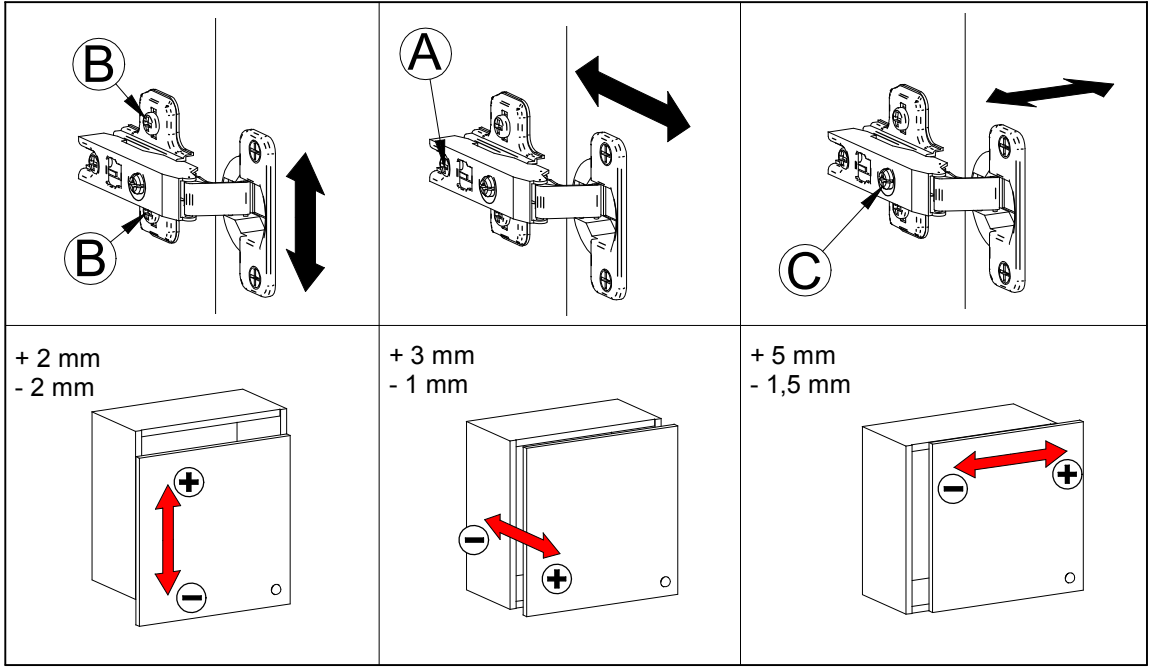

14.

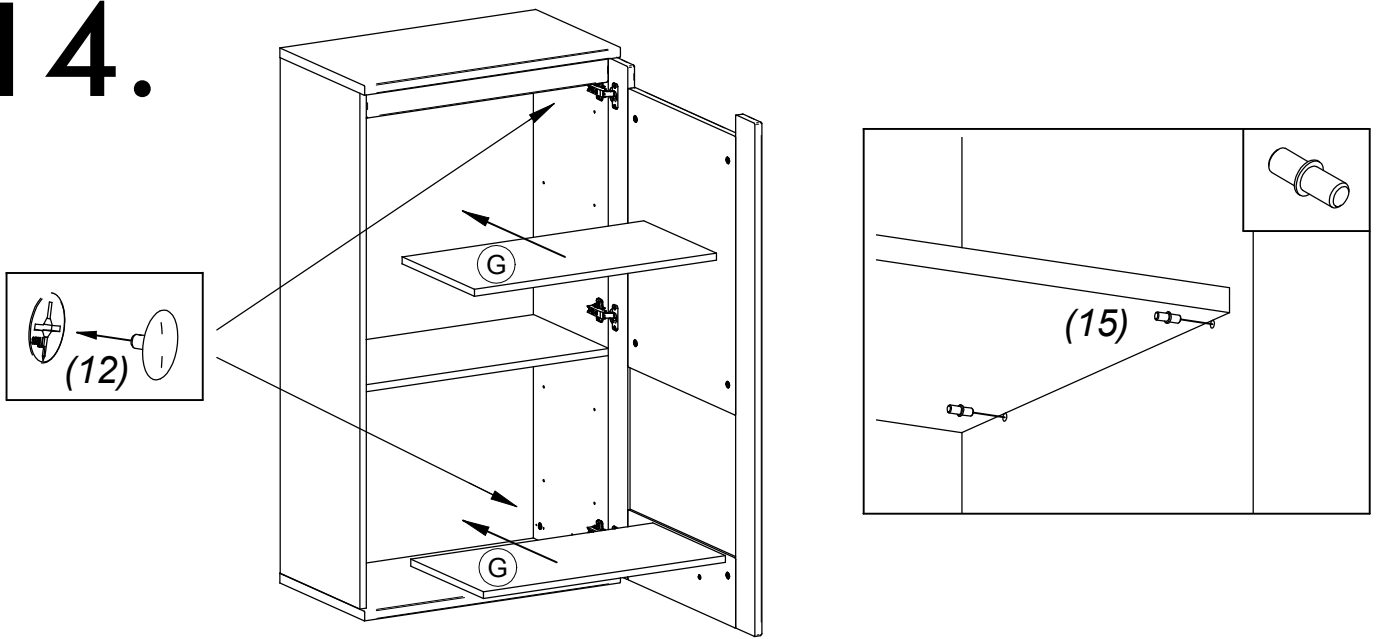



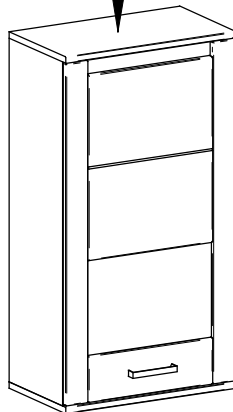



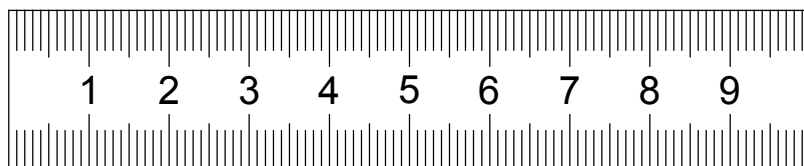
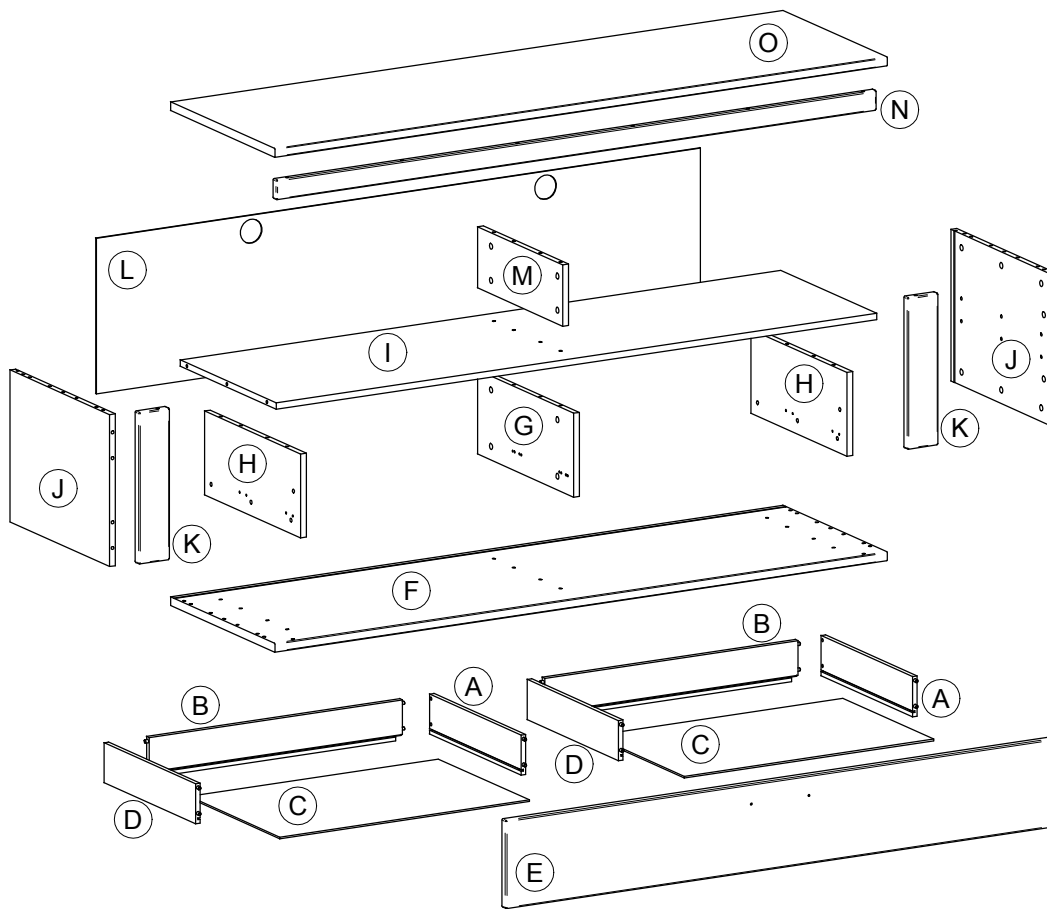
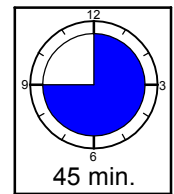
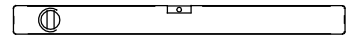
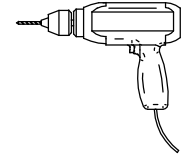
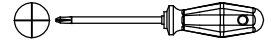
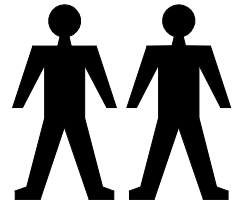
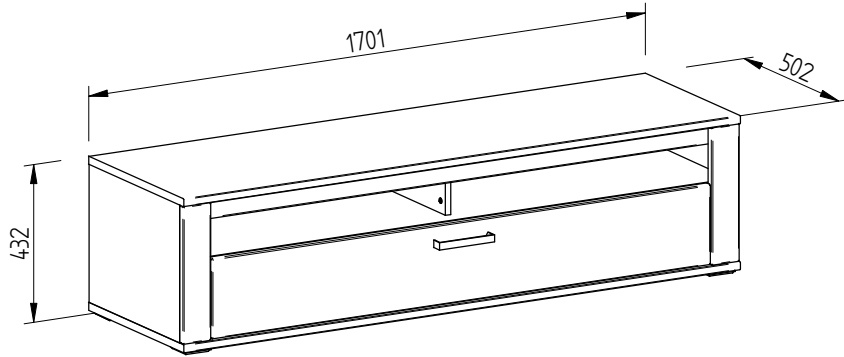

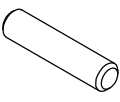
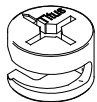
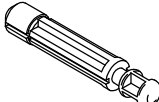
  **Max. 15kg**

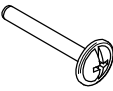
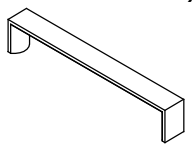
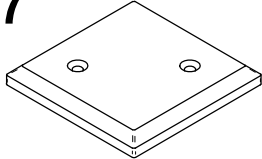

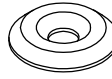
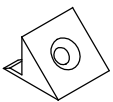
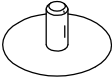
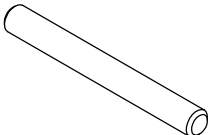
VERONA 31

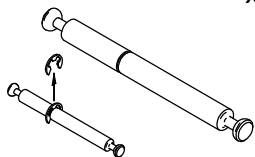
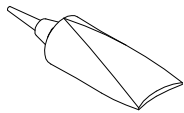
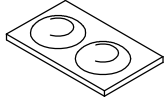

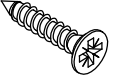
1 $\varnothing 8 \times 35$ x54 	2 $\varnothing 15$ x24 	3 $\varnothing 8$ x20 	4 $\varnothing 3 \times 15$ x4 	5 $\varnothing 4 \times 25$ x2 
6 x1 	7 x5 	8 $\varnothing 3,5 \times 20$ x26 	9 $\varnothing 12$ x8 	10 x18 
11 $\varnothing 15$ x10 	12 $\varnothing 8 \times 70$ x2 	13 $\varnothing 6,3 \times 11$ x8 	14 $\varnothing 8$ x2 	15 x1  Vor Gebrauch schütteln Shake before use Pred použitím zatrepat'
16 x1 	17  440 mm			18 $\varnothing 4 \times 20$ x10 

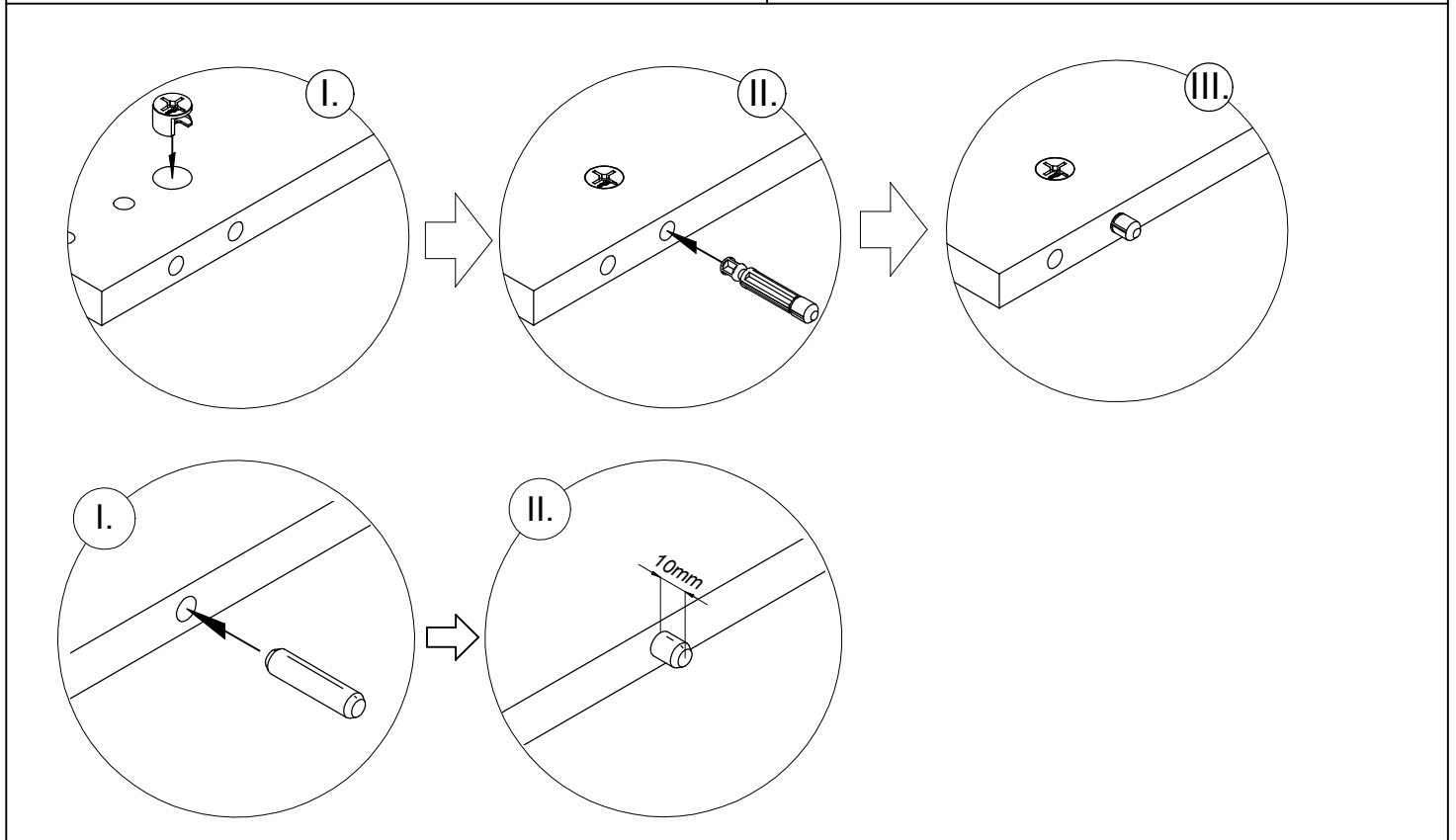
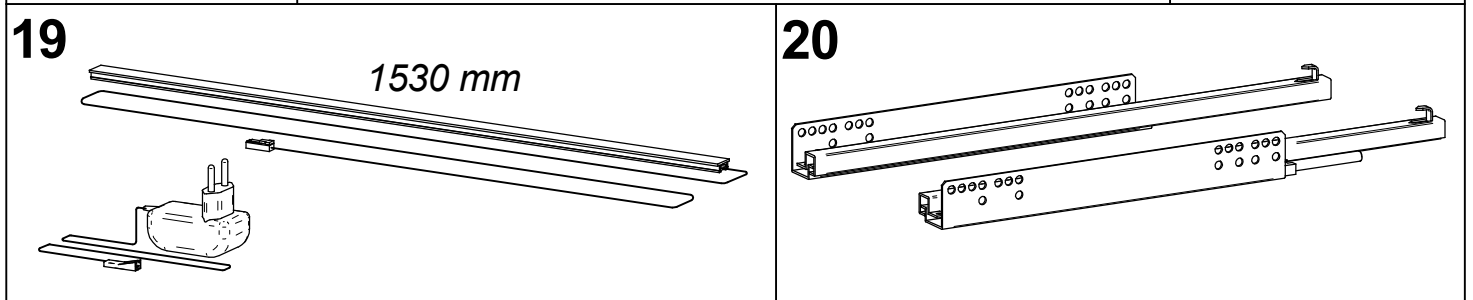

1.

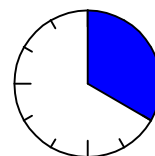
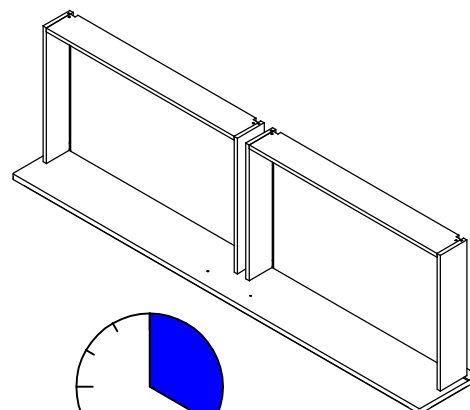
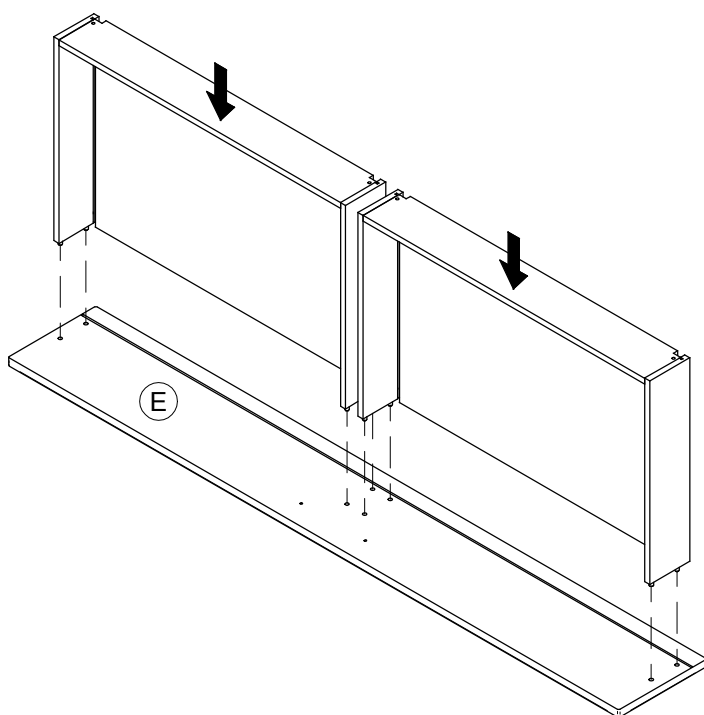
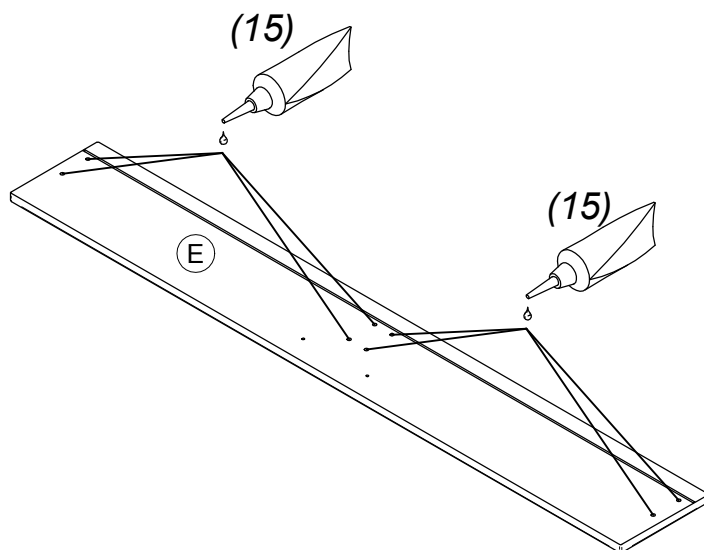
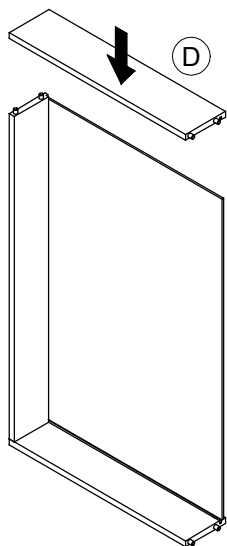
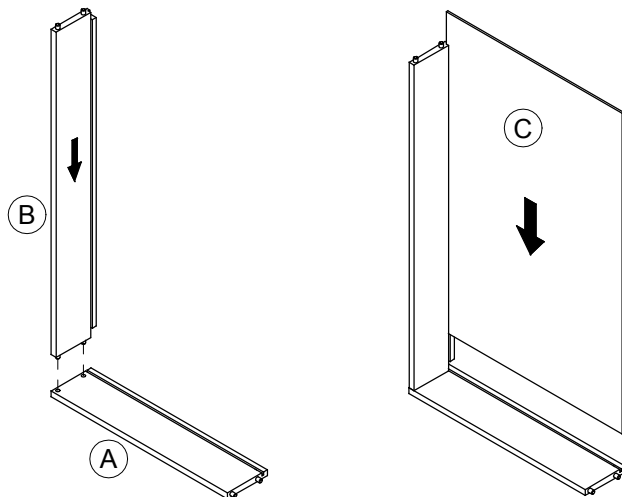
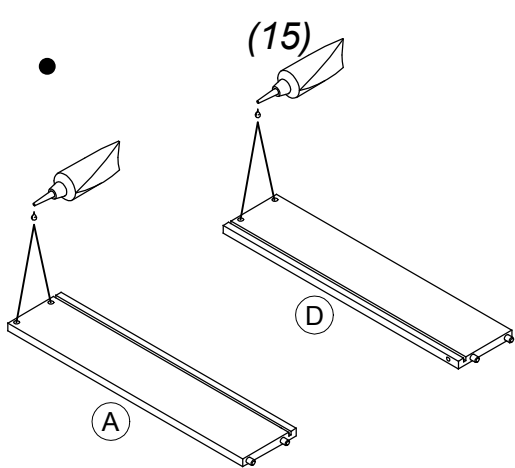

20 min

Trocken lassen!
Nechat' sušit!

2.

2.1

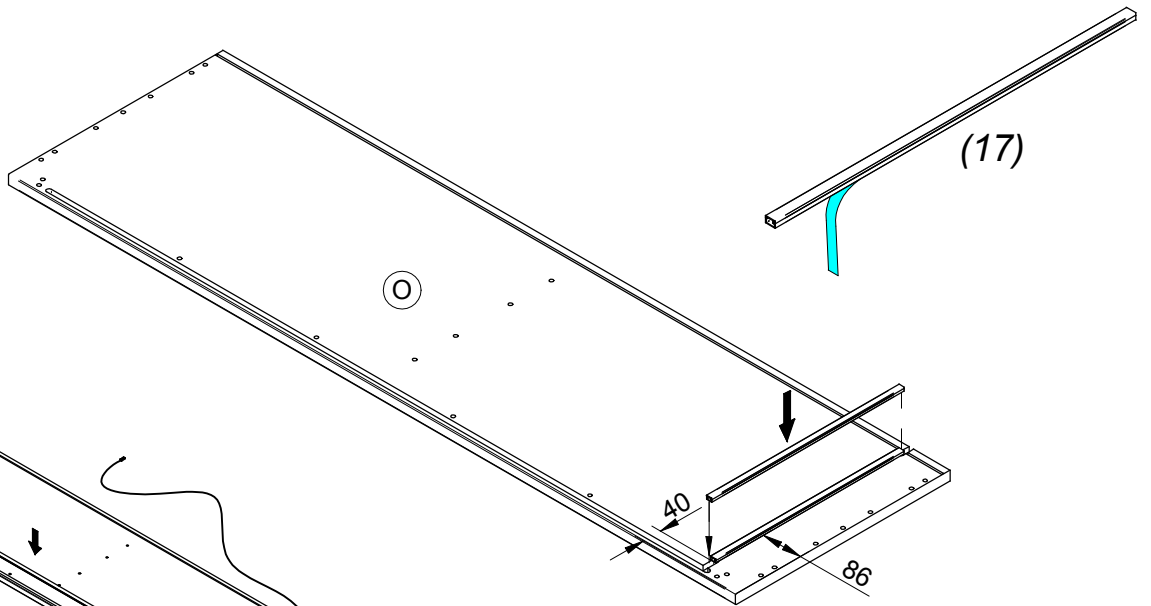

2.2

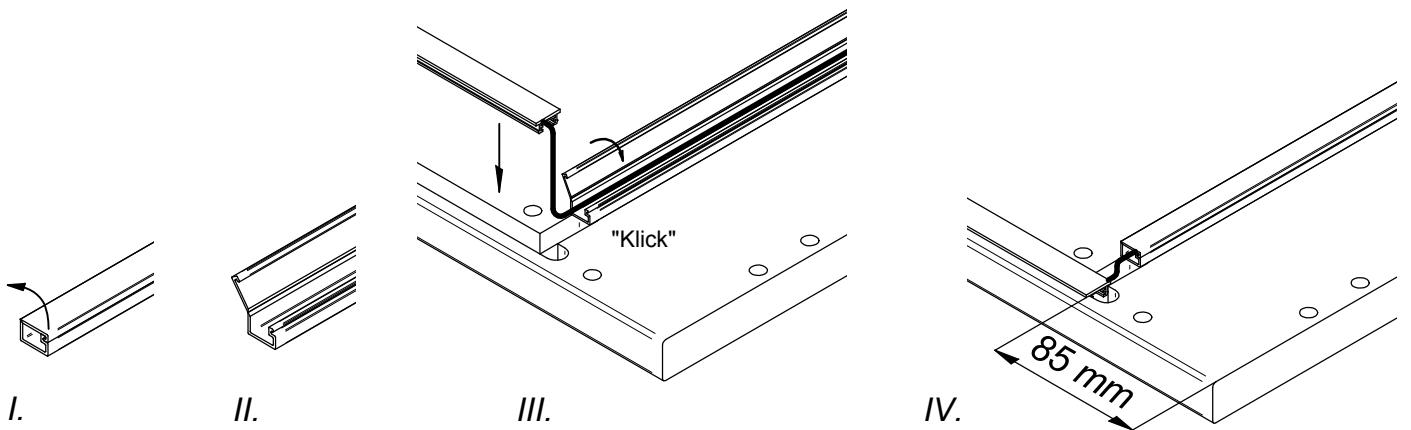
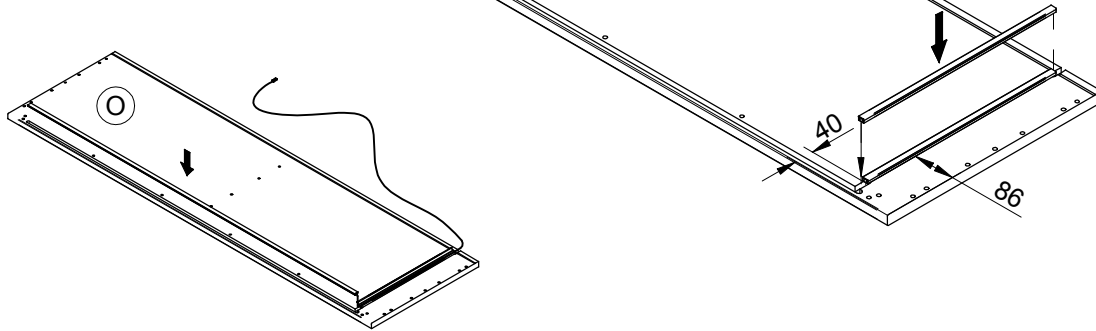

2.3

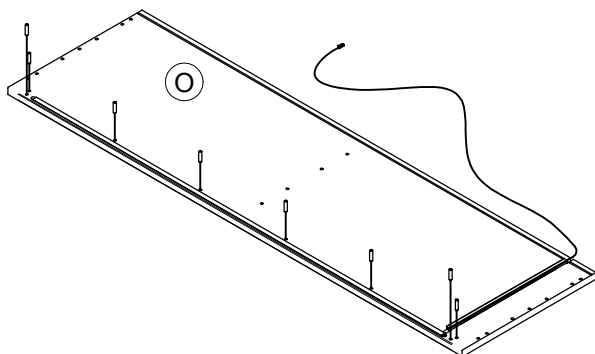
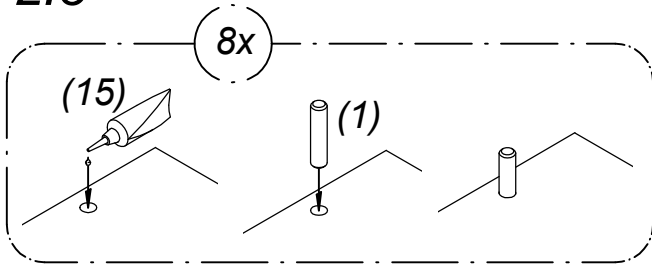

2.4

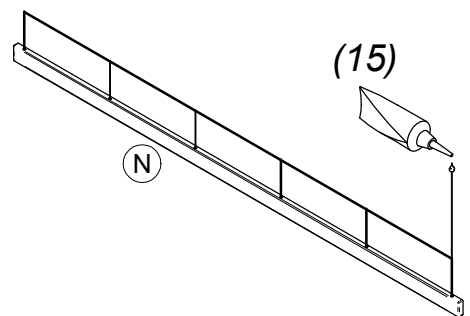

2.5

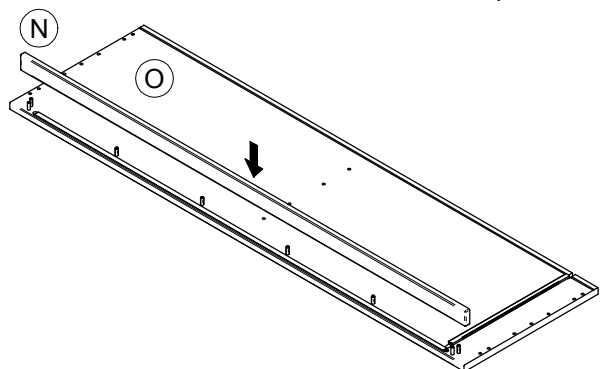

3.

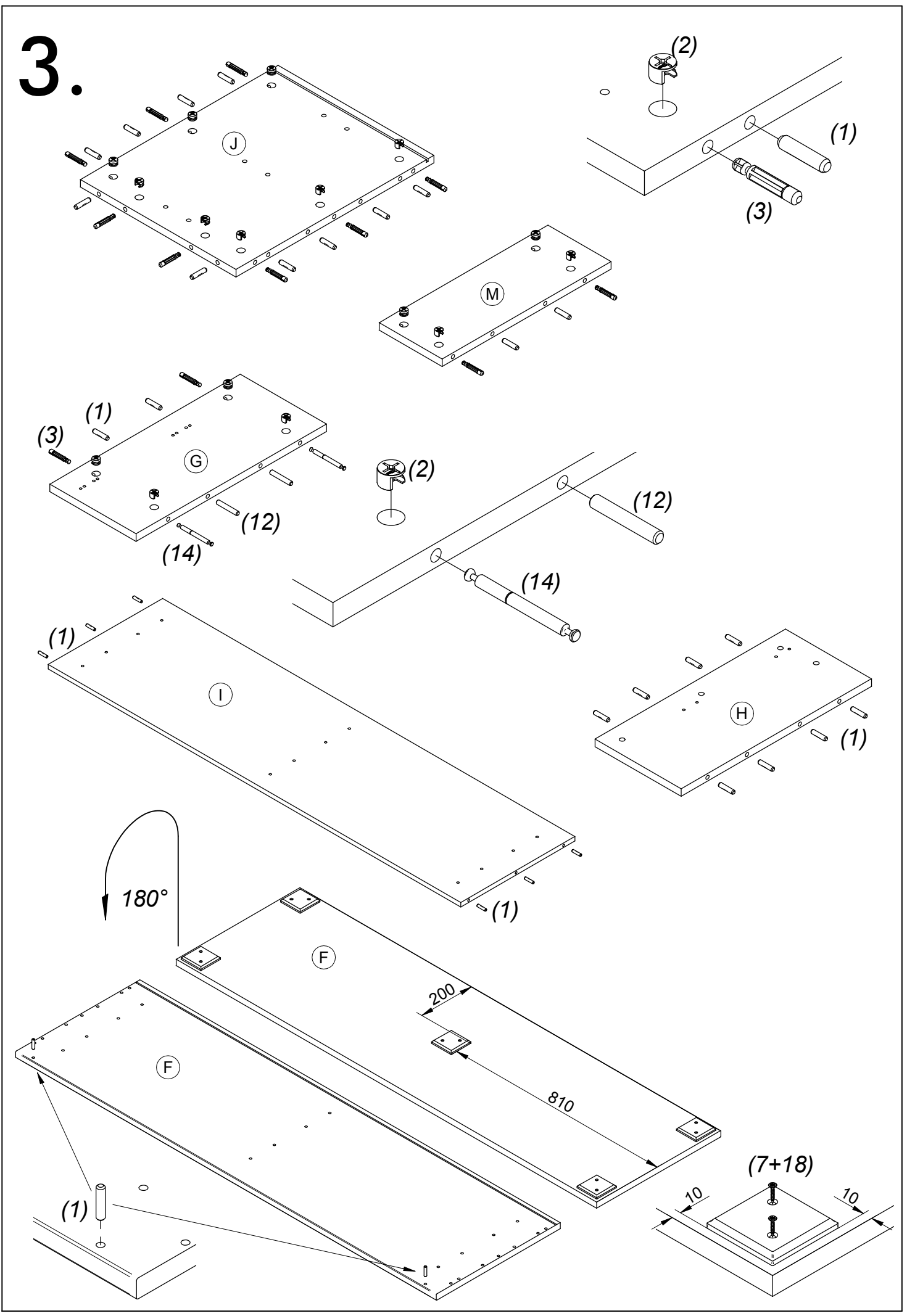

4.

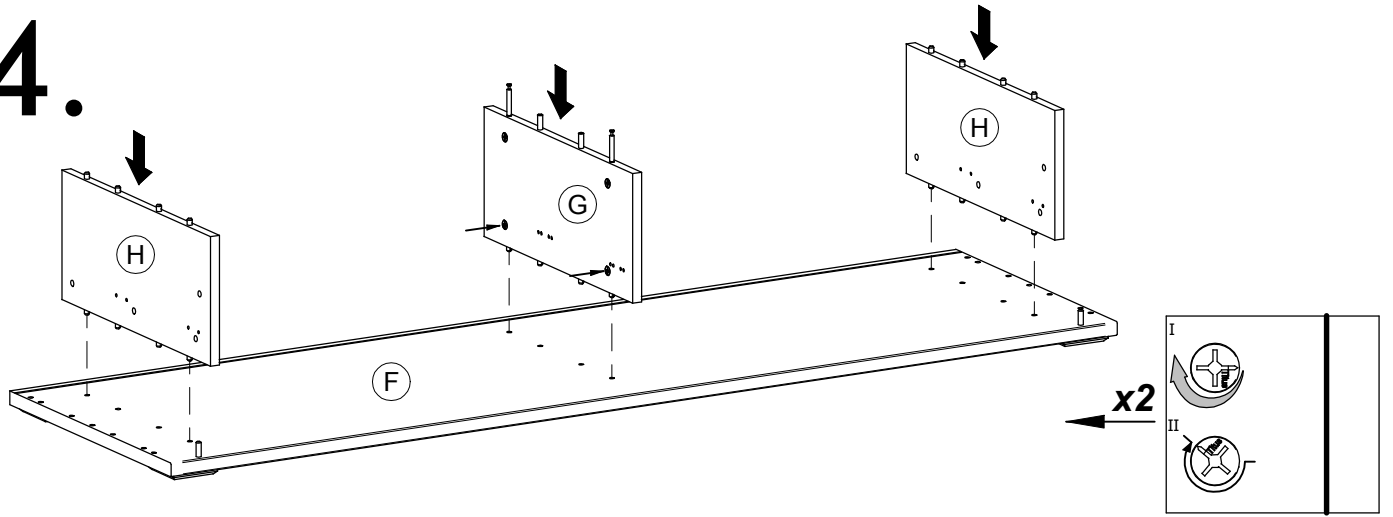

5.

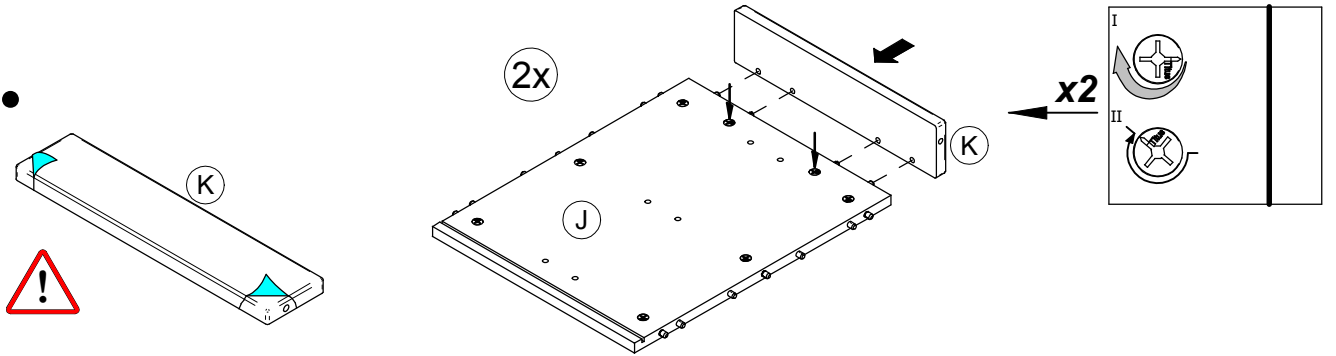

6.

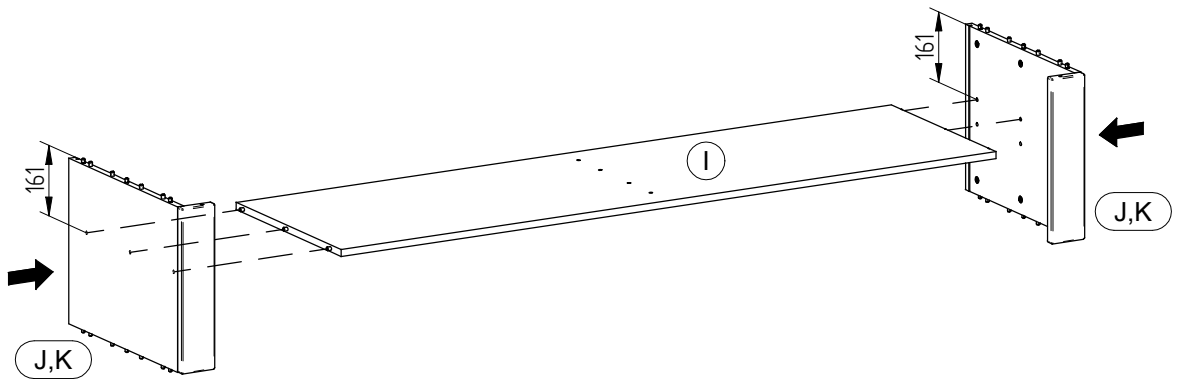

7.

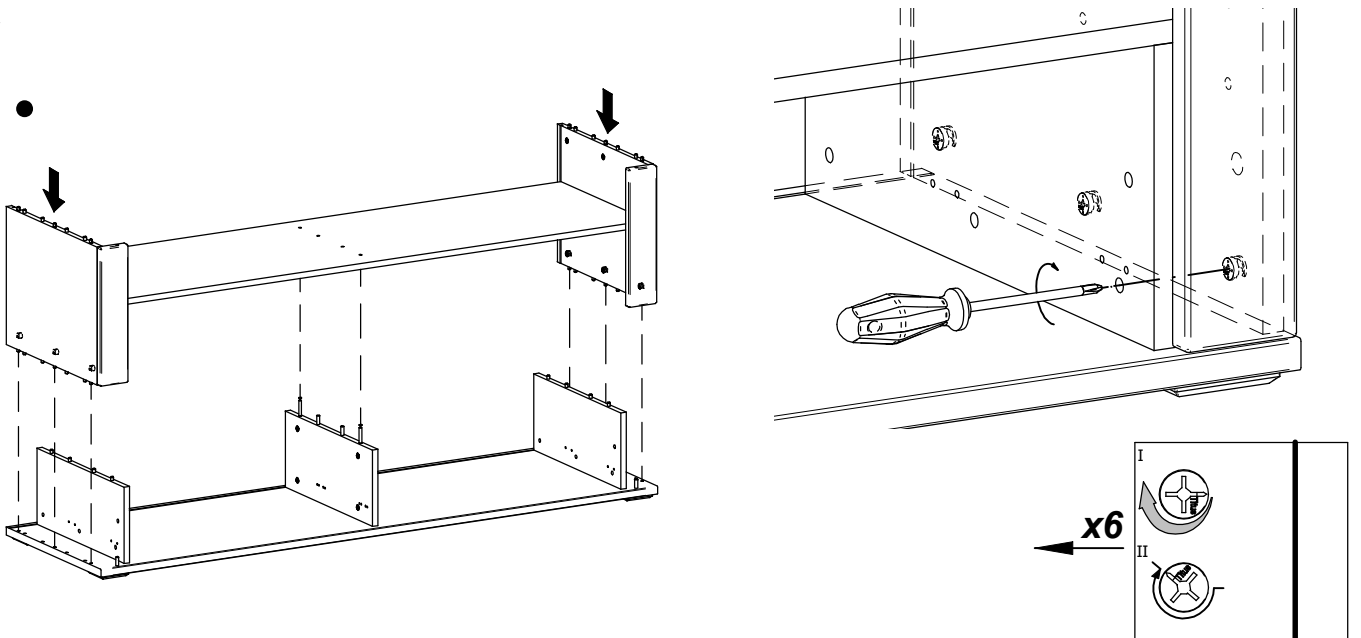

8.

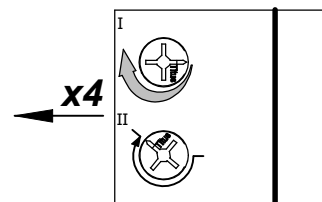
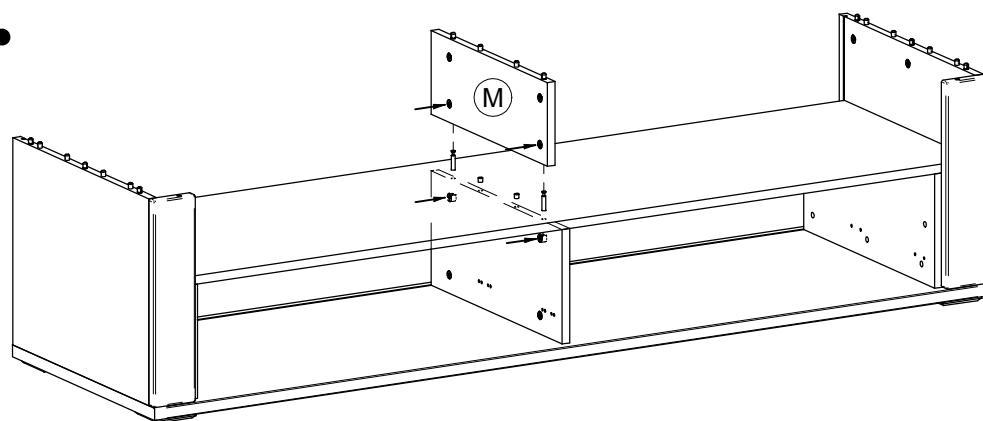

9.

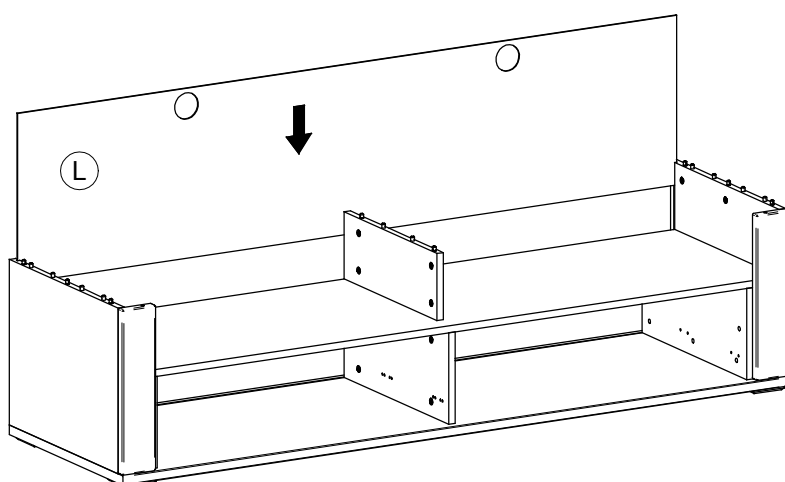

10.

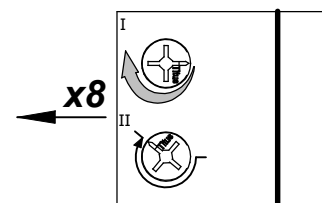
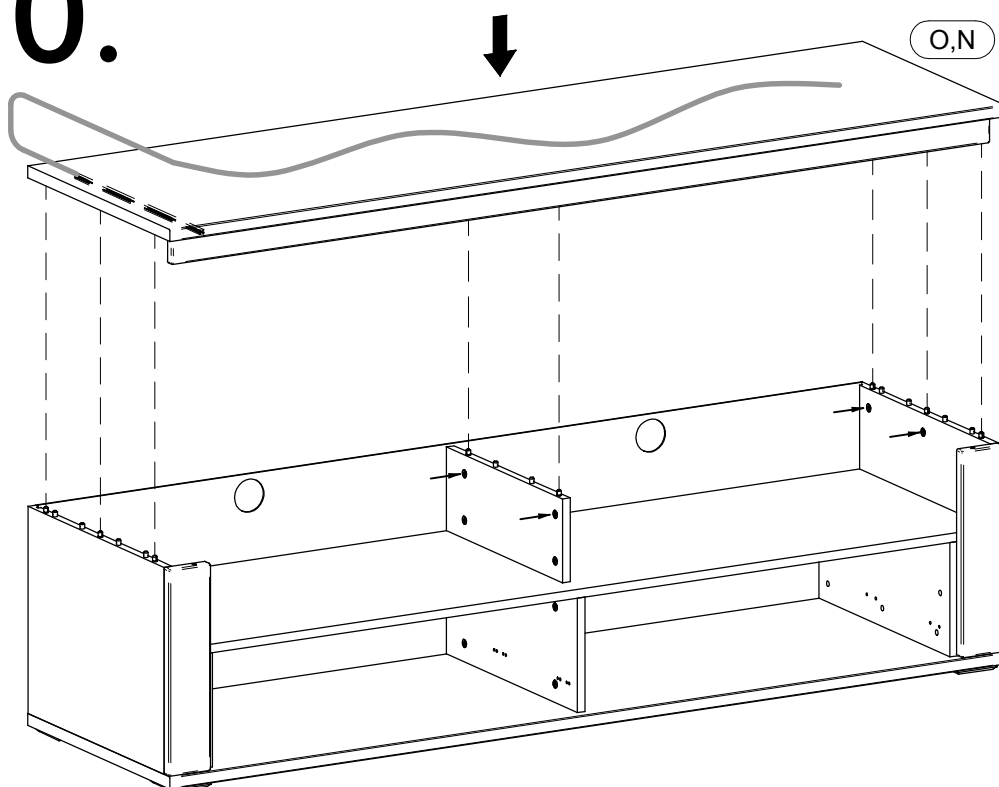

11.

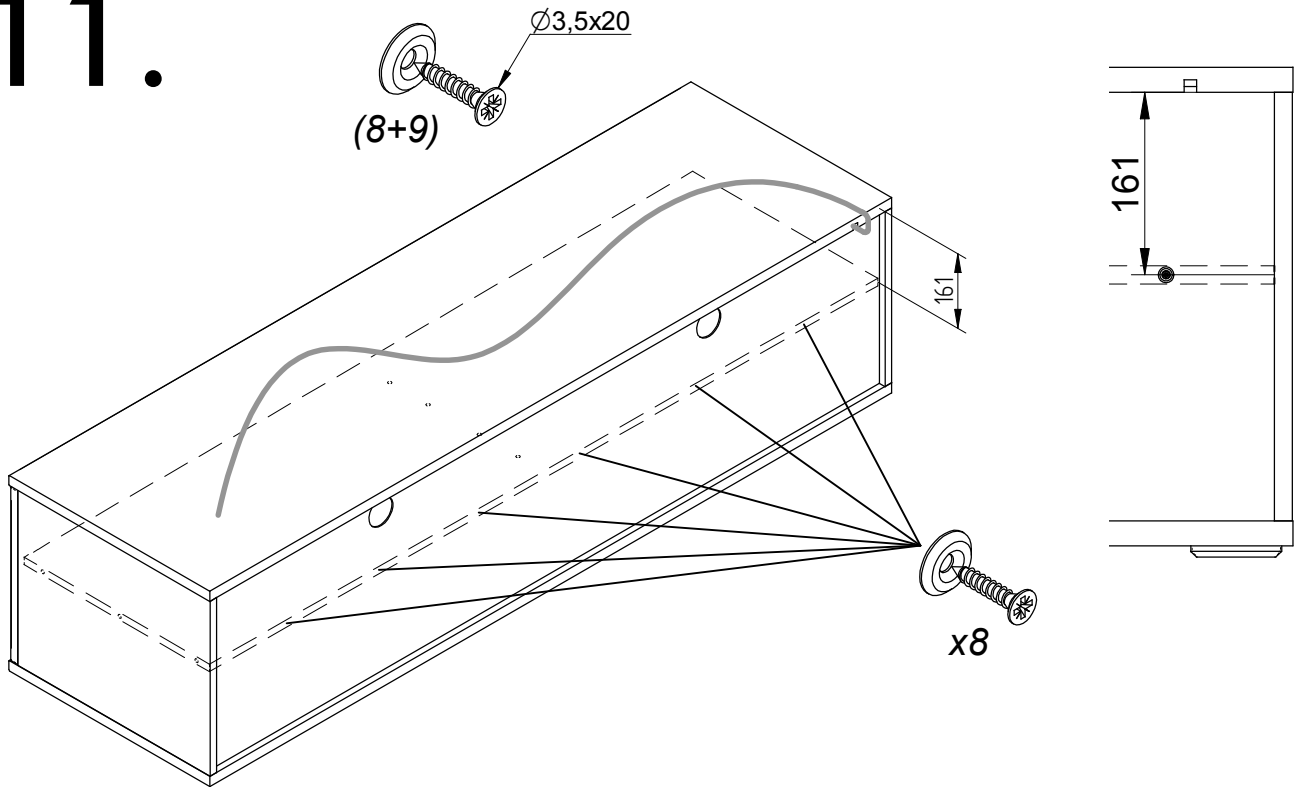

12.

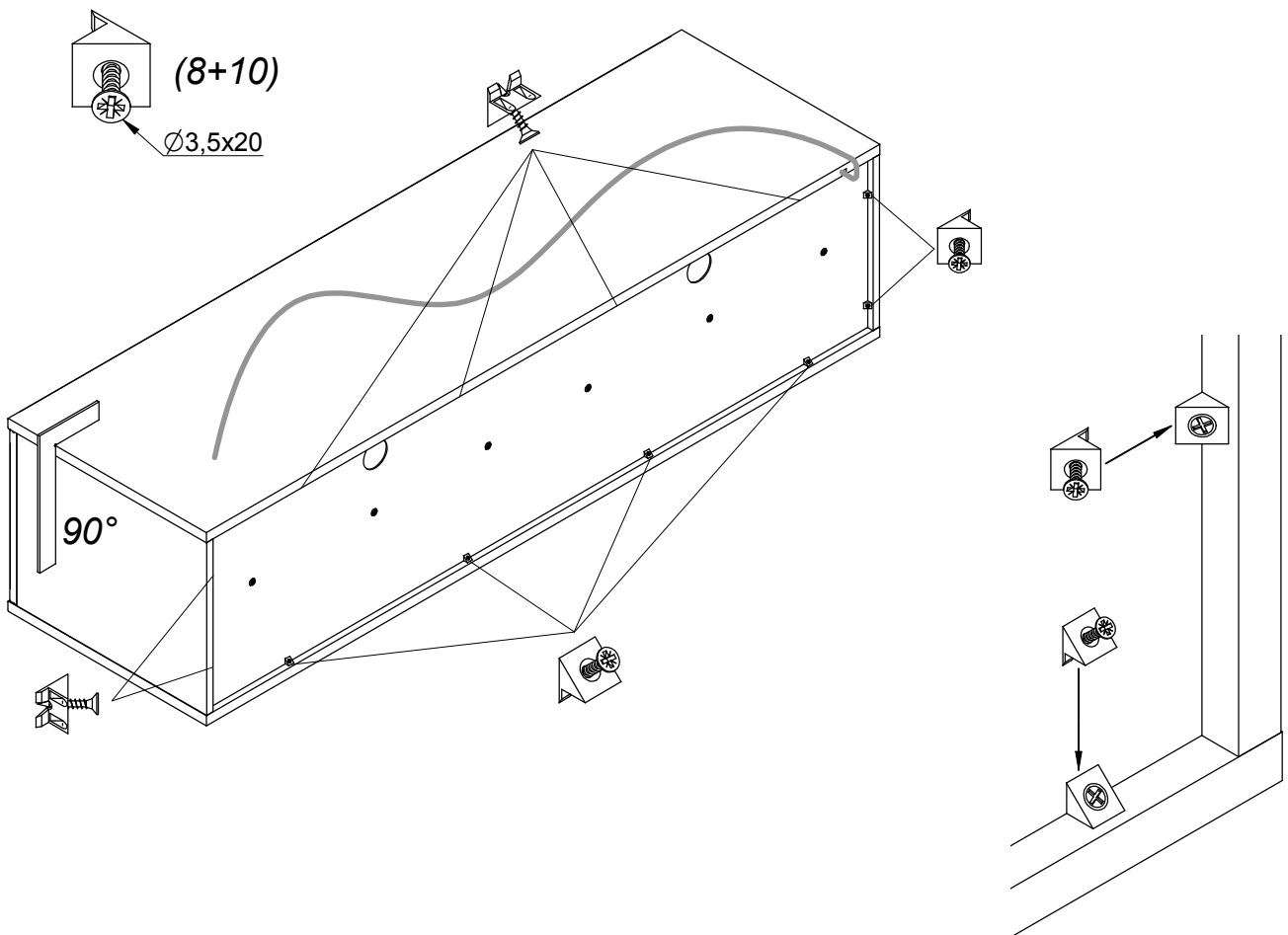

13.

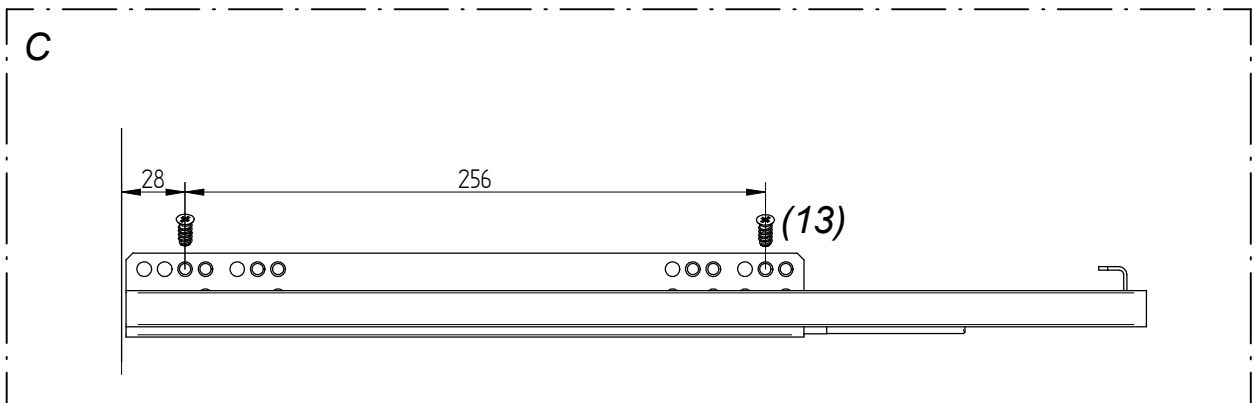
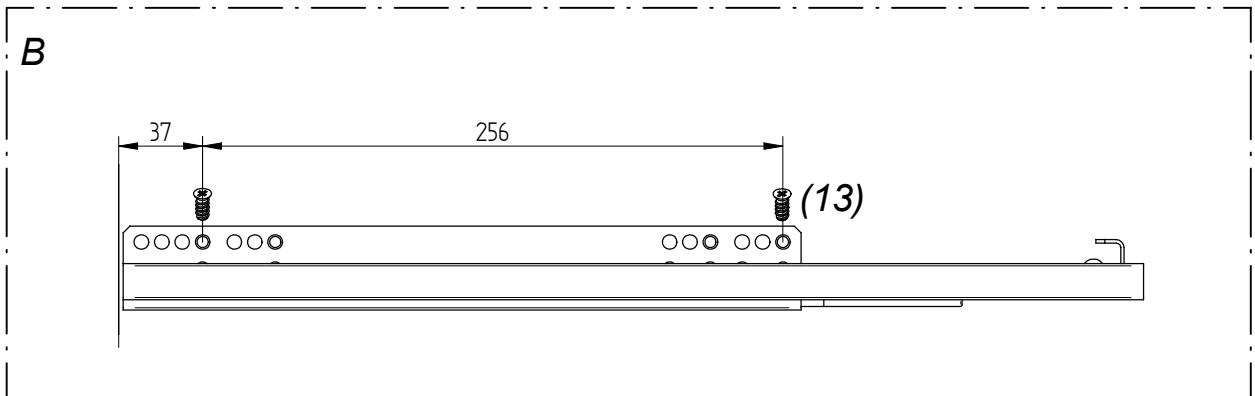
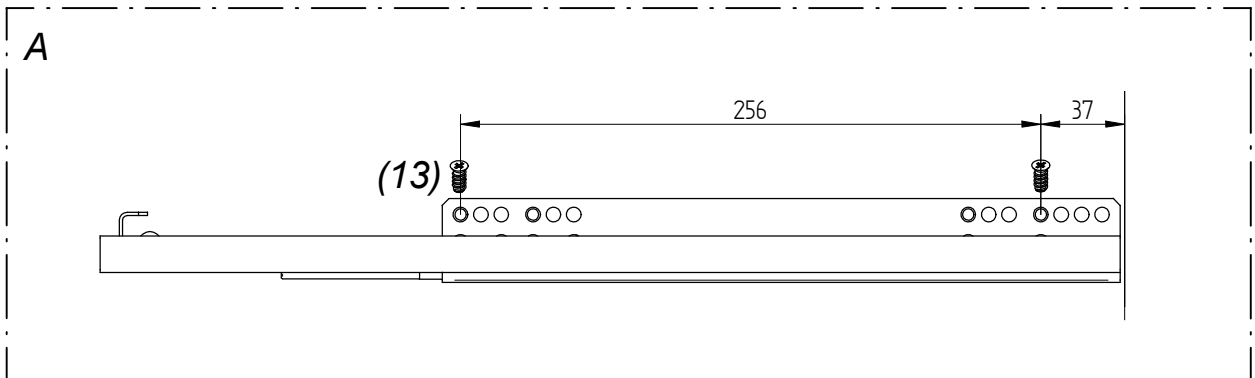
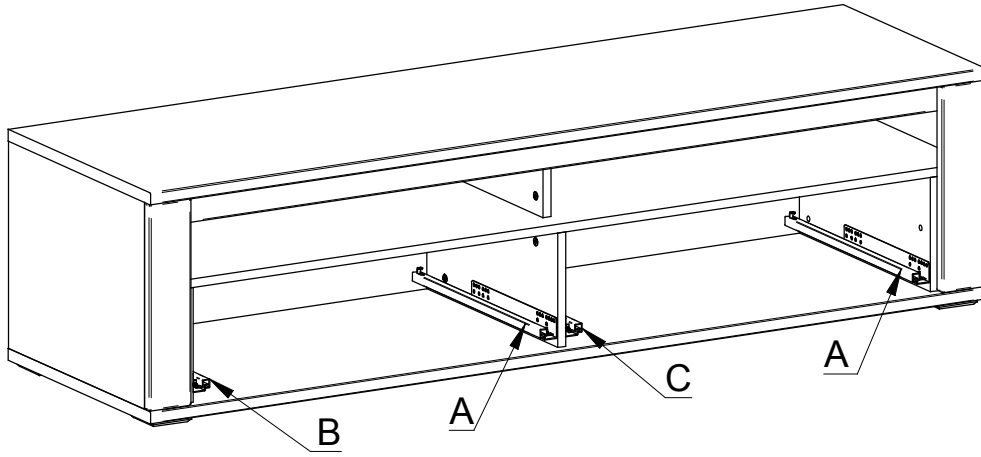

14.

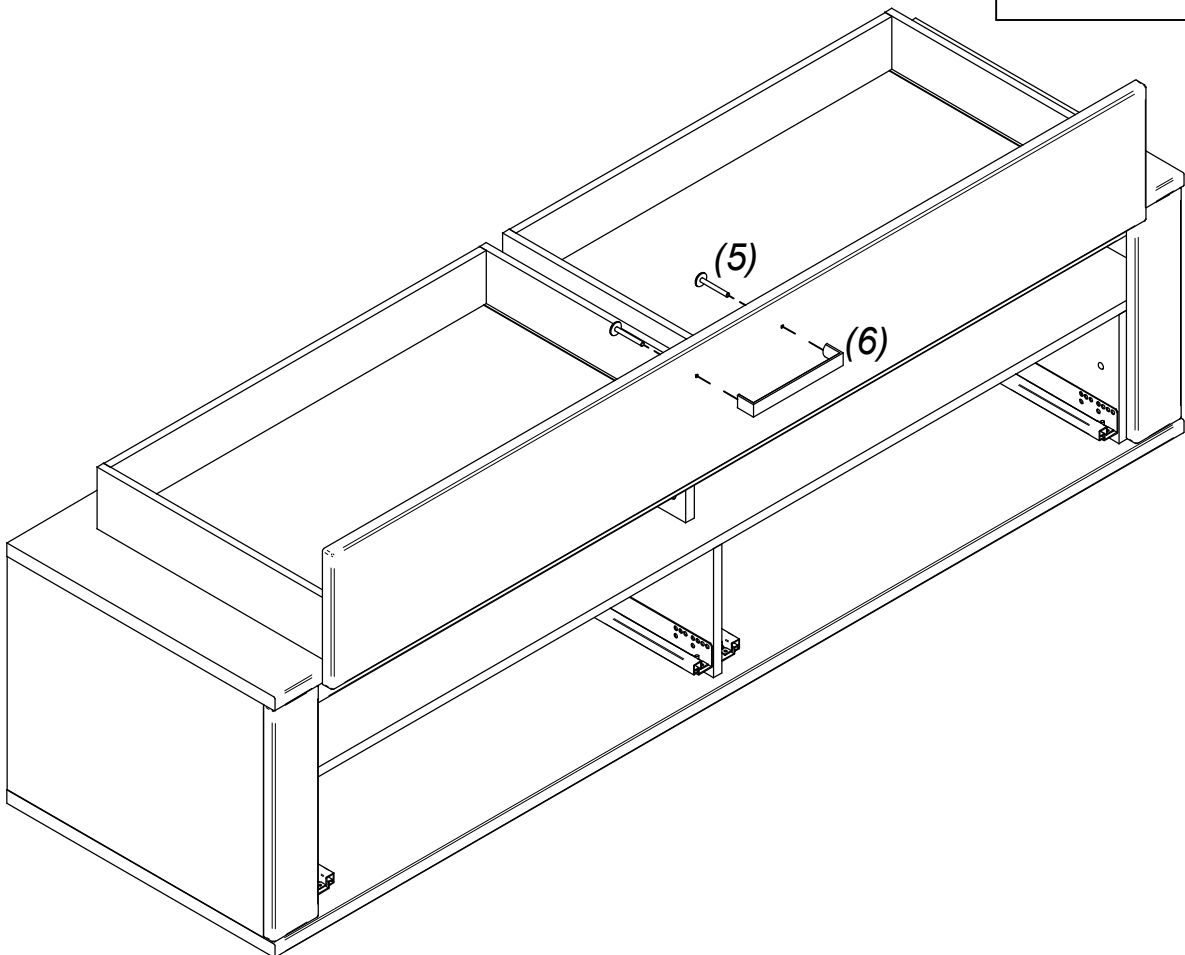
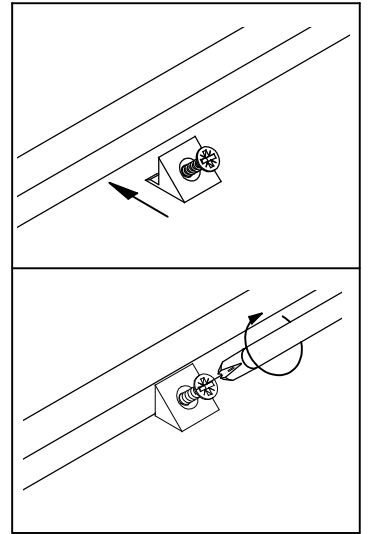
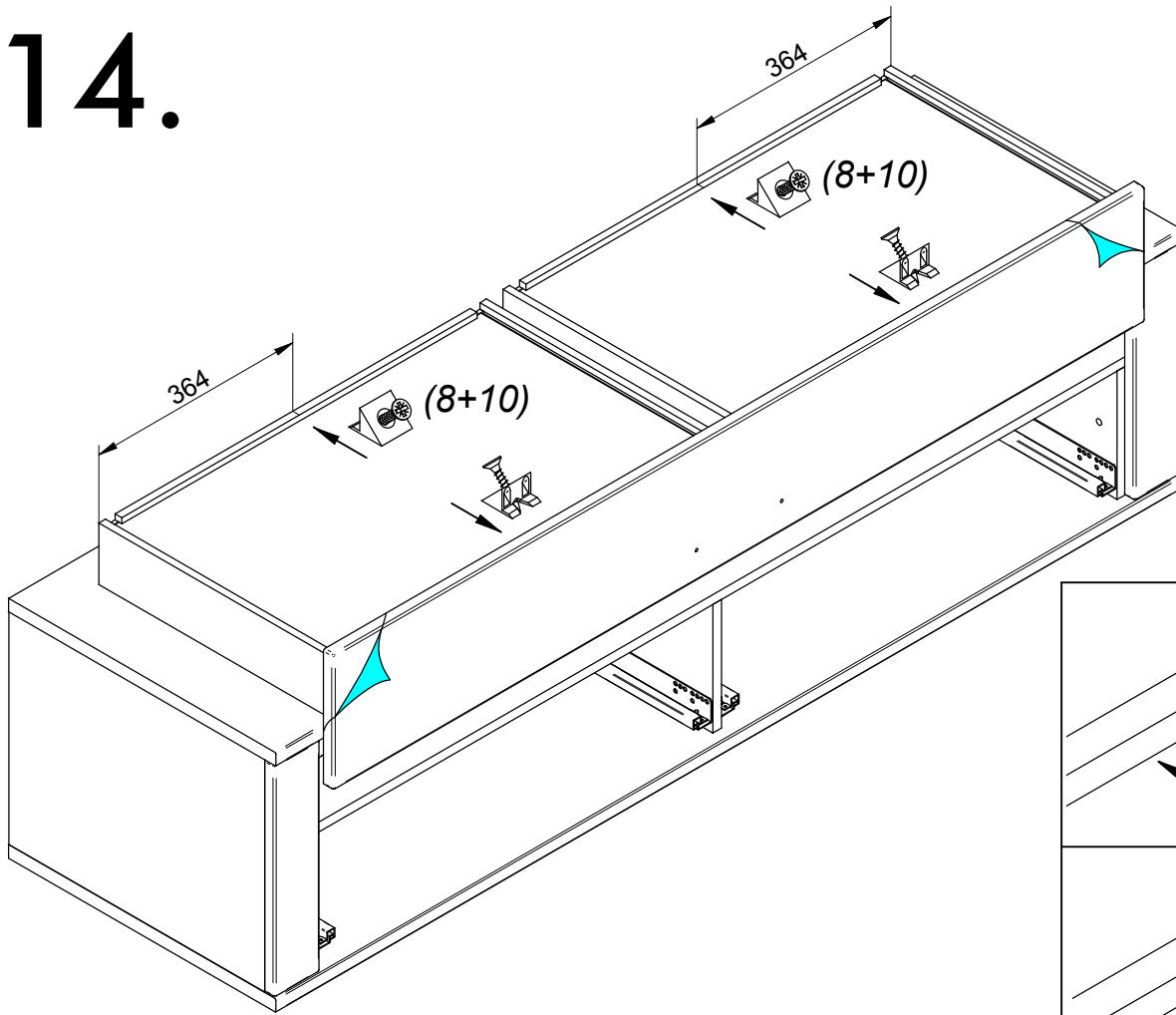

15.

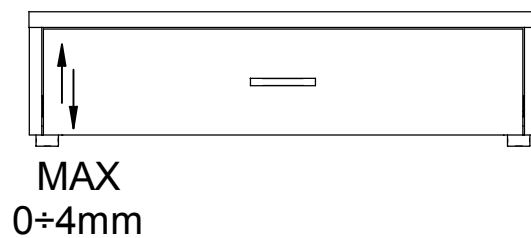
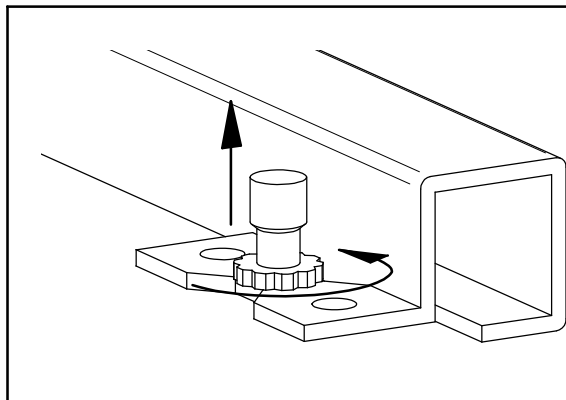
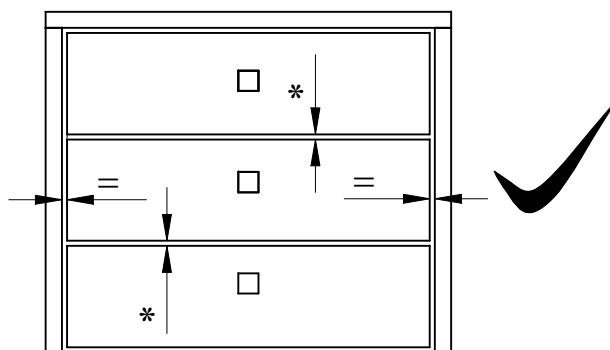
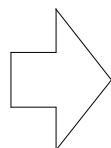
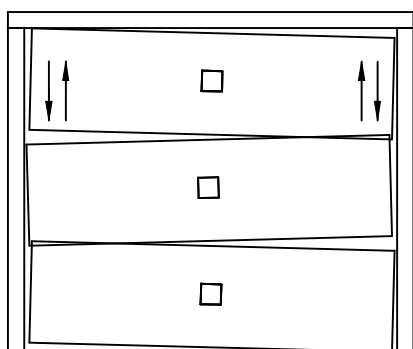
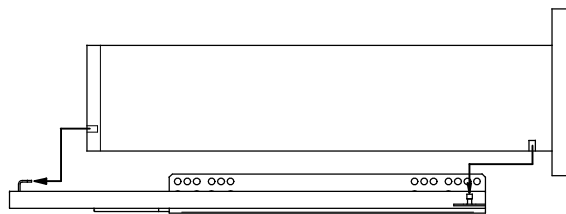
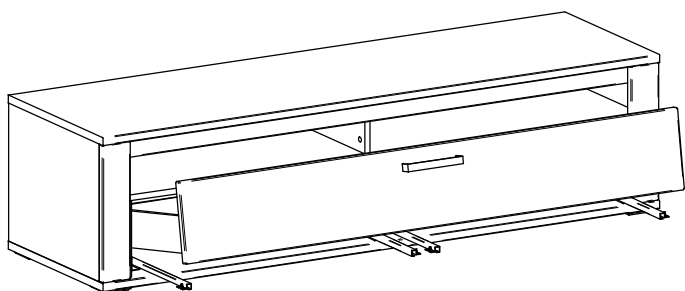

MAX
0÷4mm

