

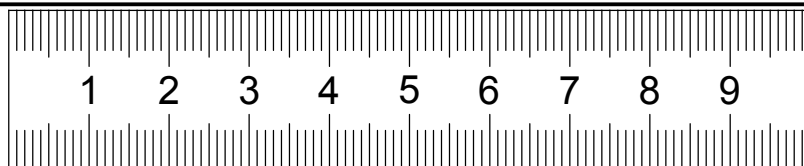

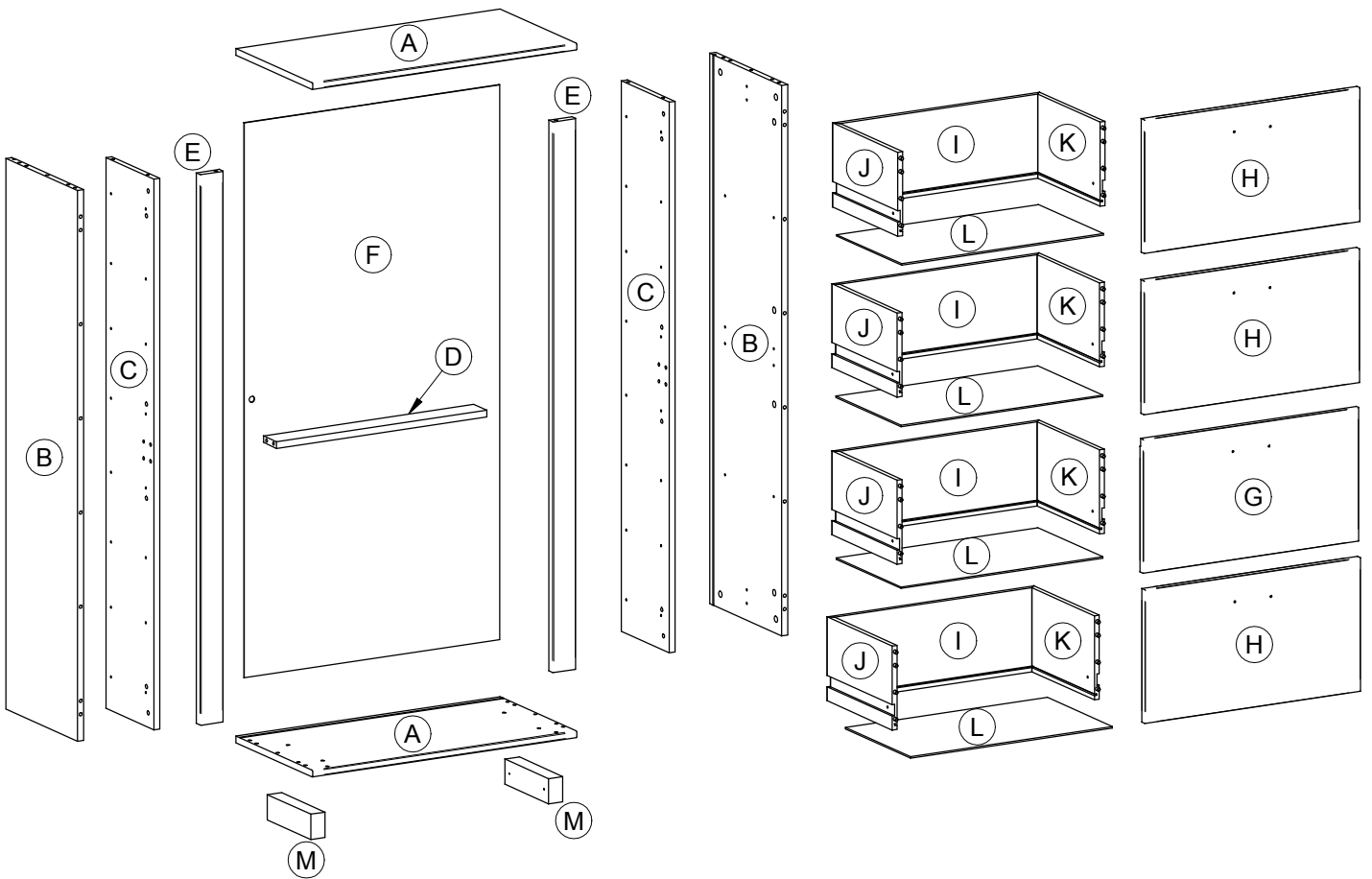

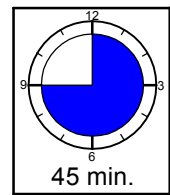

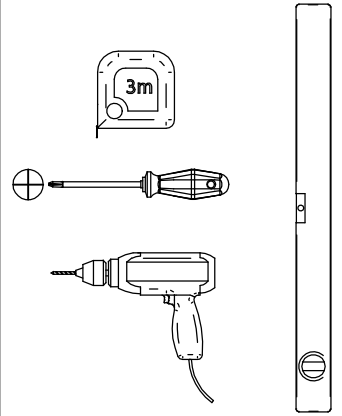

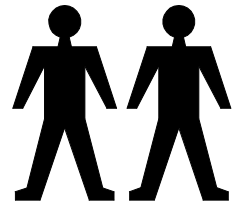
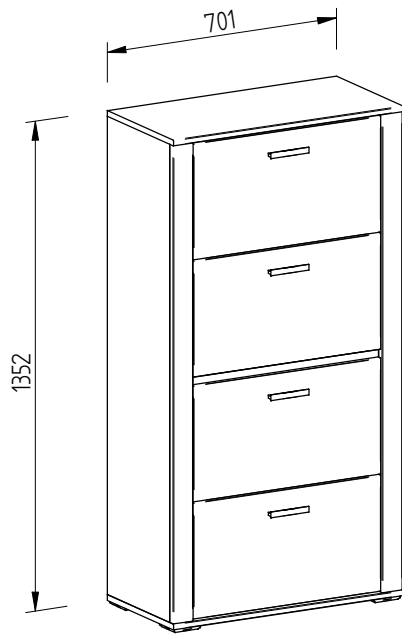
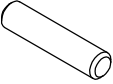

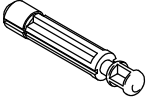
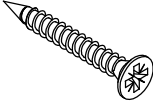

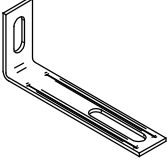
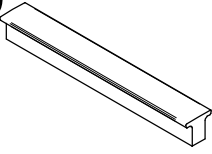

# BENO 05

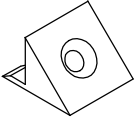

<b>1</b> $\varnothing 8 \times 35$ x34 	<b>2</b> $\varnothing 15$ x18 	<b>3</b> $\varnothing 8$ x18 	<b>4</b> $\varnothing 4 \times 30$ x4 	<b>5</b> M4x20 x8 
<b>6</b> $\varnothing 4 \times 20$ x8 	<b>7</b> $\varnothing 6,5$ x3 	<b>8</b> $\varnothing 3,5 \times 15$ x2 	<b>9</b> x1 	<b>10</b> x4 
<b>11</b> $\varnothing 6,3 \times 11$ x24 	<b>12</b> x18 	<b>13</b> $\varnothing 3,5 \times 20$ x18 	<b>14</b> $\varnothing 3 \times 25$ x2 	<b>15</b> $\varnothing M4 \times 10$ x8 
<b>16</b> x8 	<b>17</b> x8 	<b>18</b> x4 	<b>19</b> x1 	
<b>20</b> x1 	<b>21</b> x1 	<b>22</b> x2 LEIM/LEPIDLO 	<b>23</b> $\varnothing 4 \times 15$ x3 	

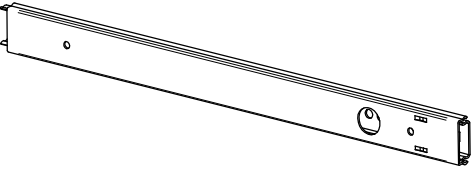
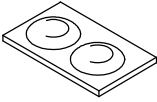
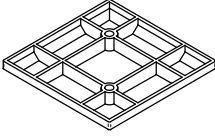
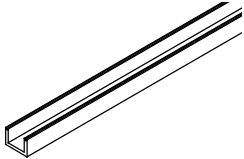
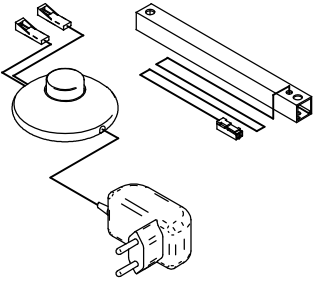
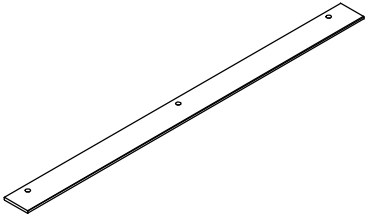
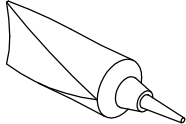

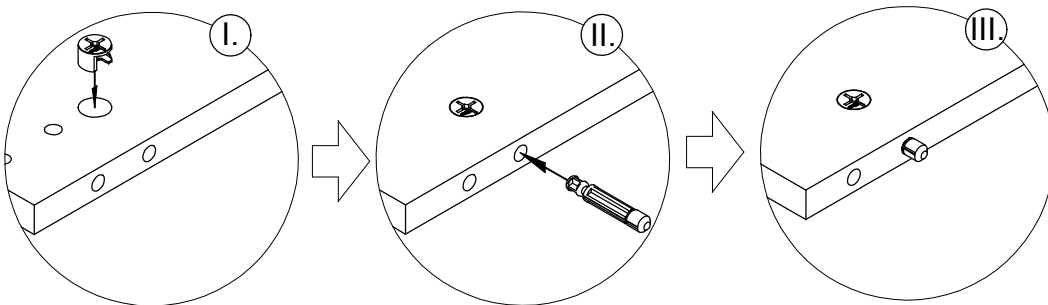
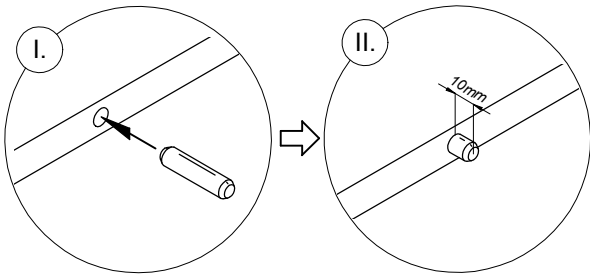
# 1.

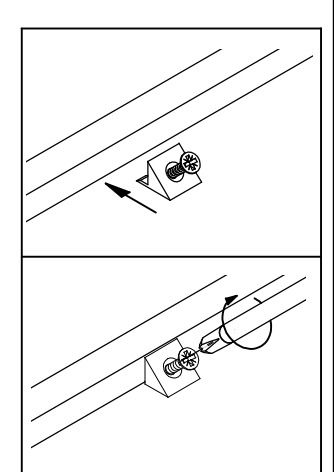
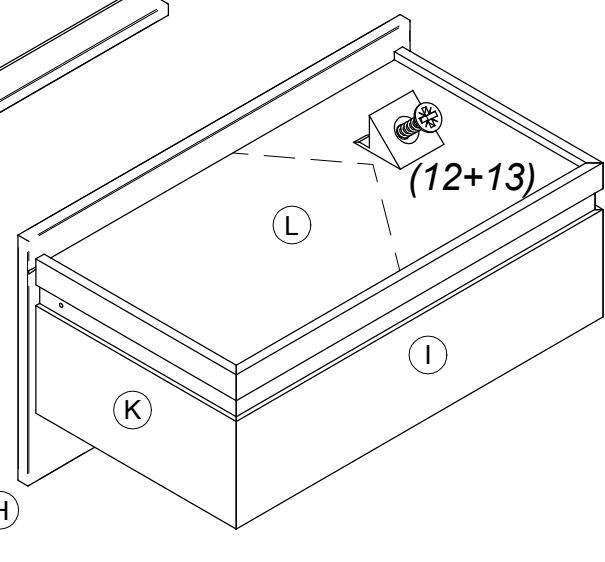
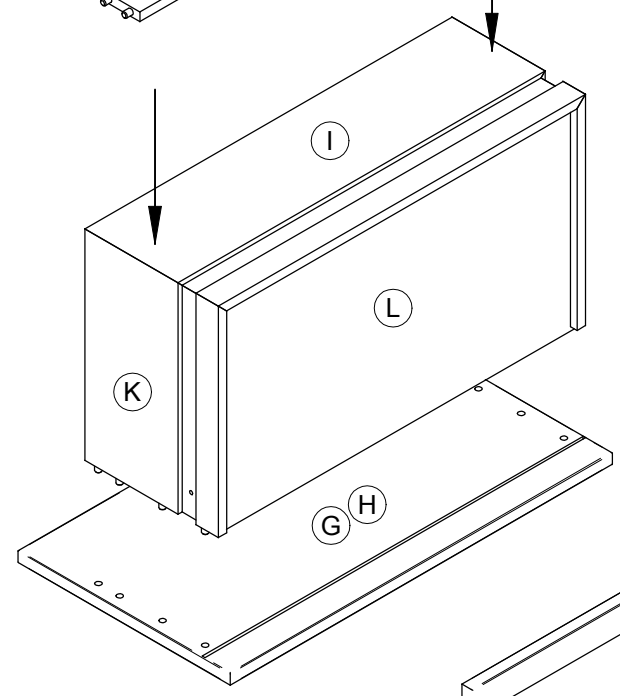
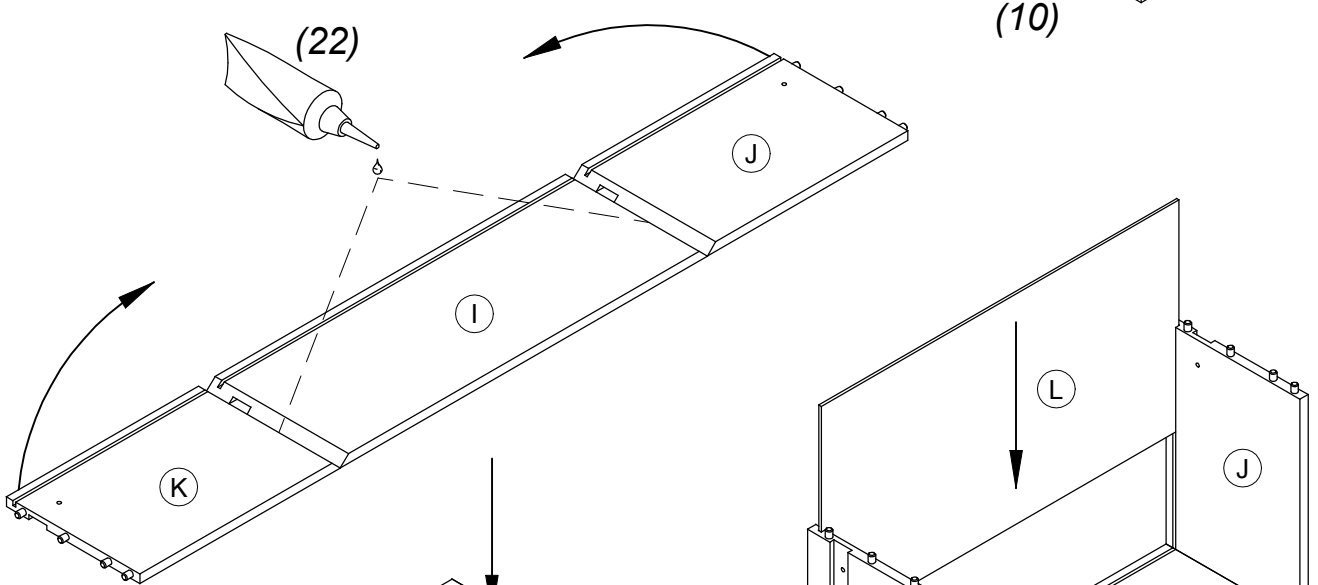
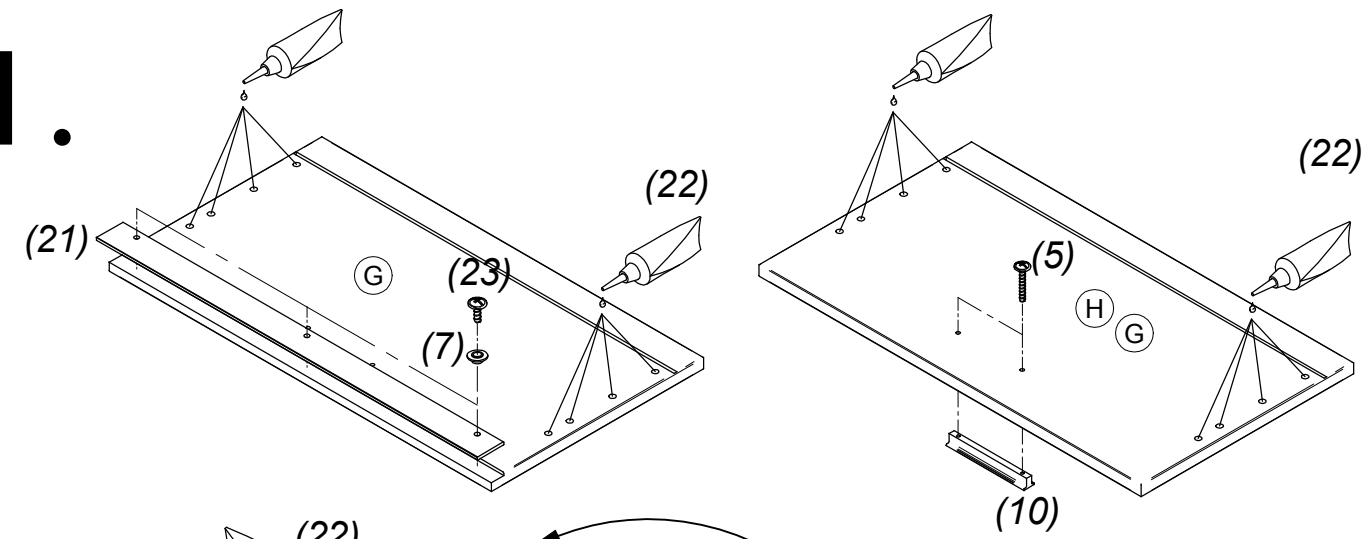

# 2.

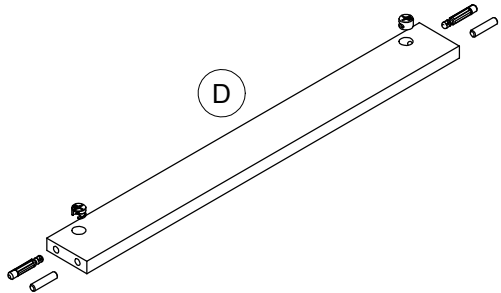
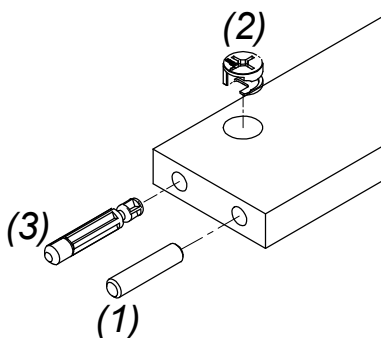
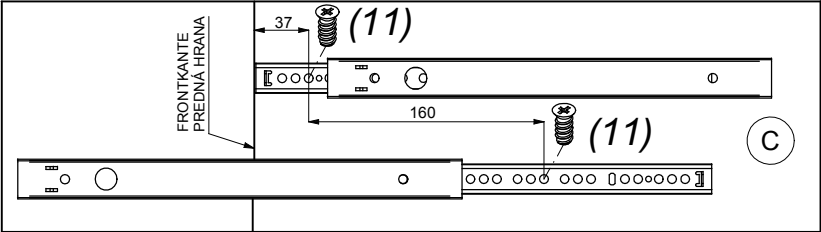
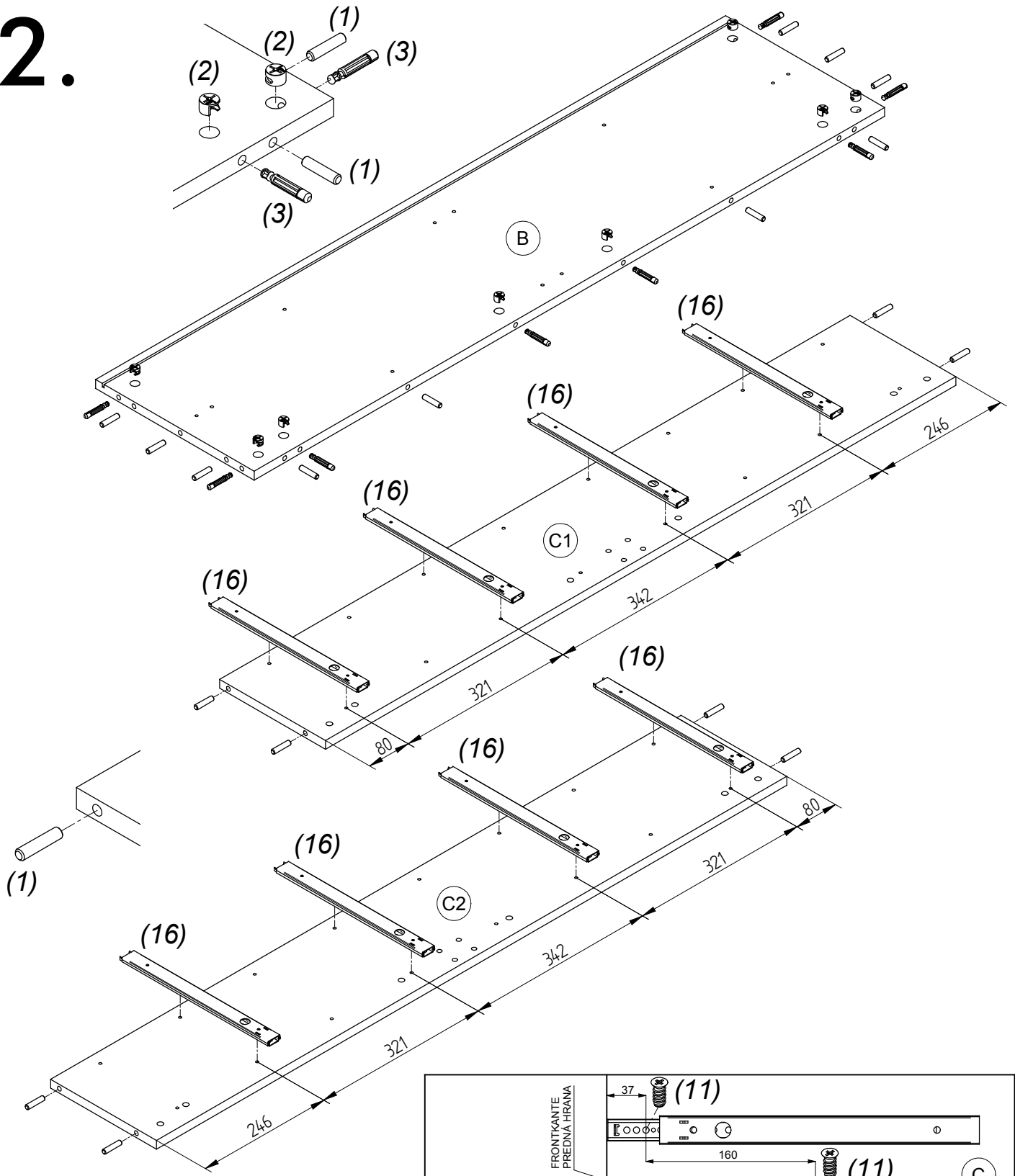

# 3.

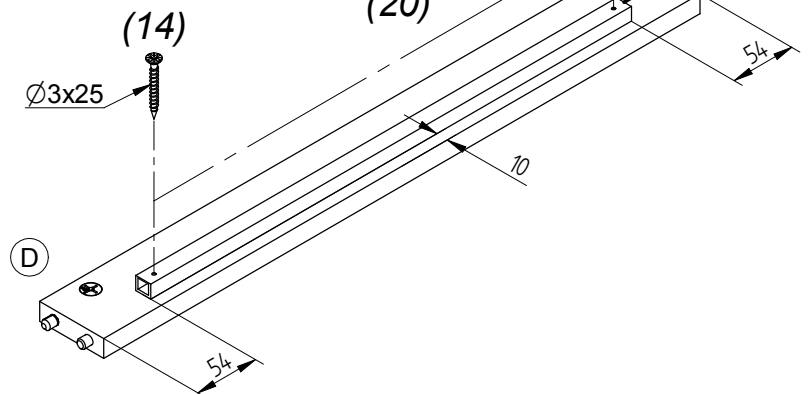
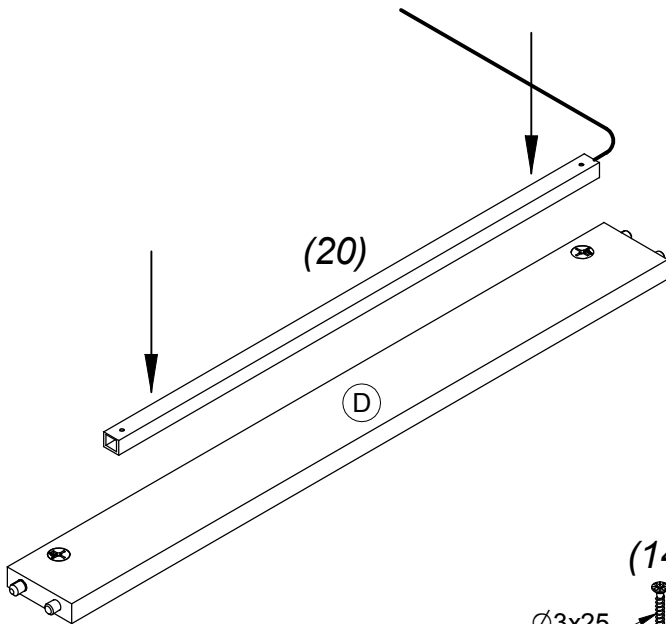
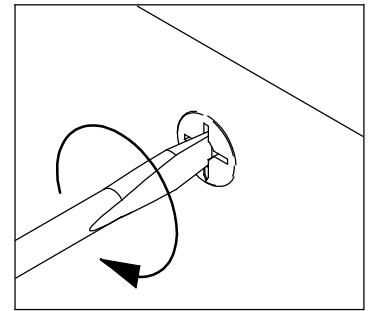
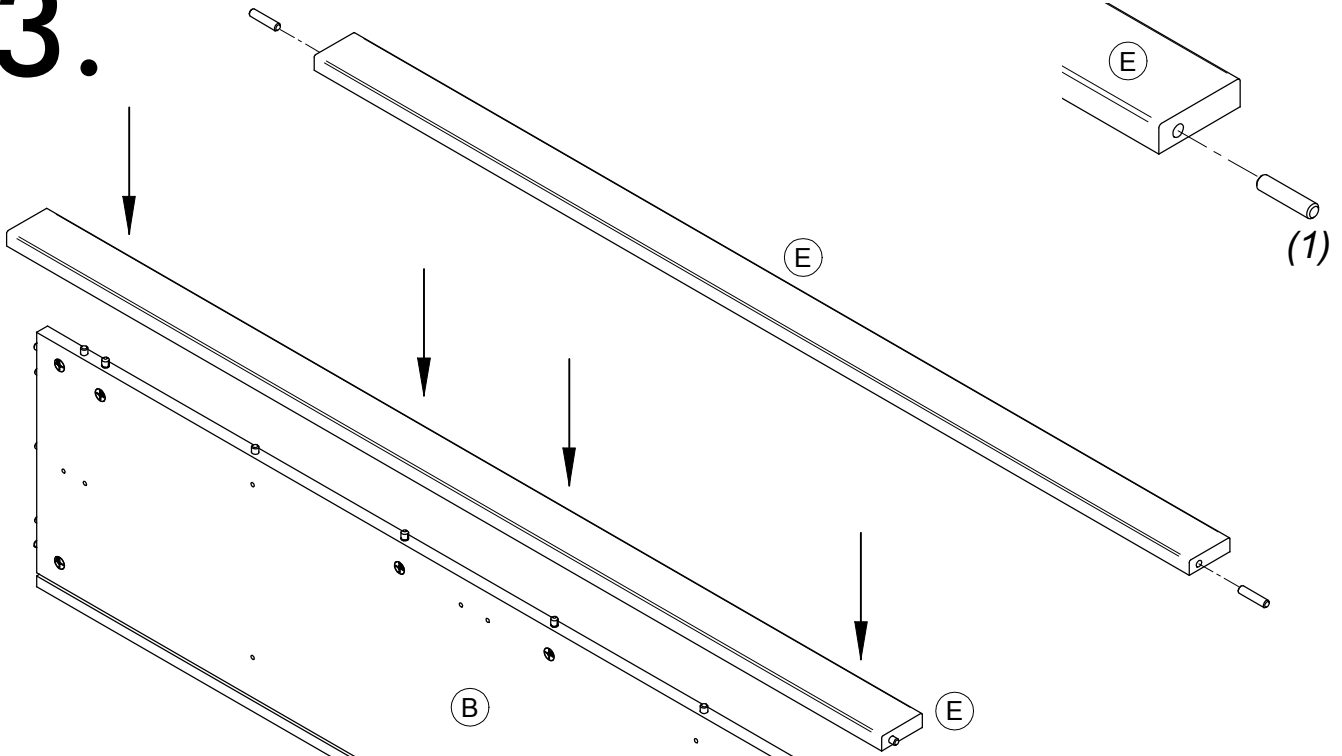

# 4.

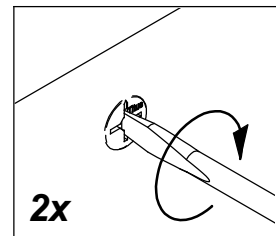
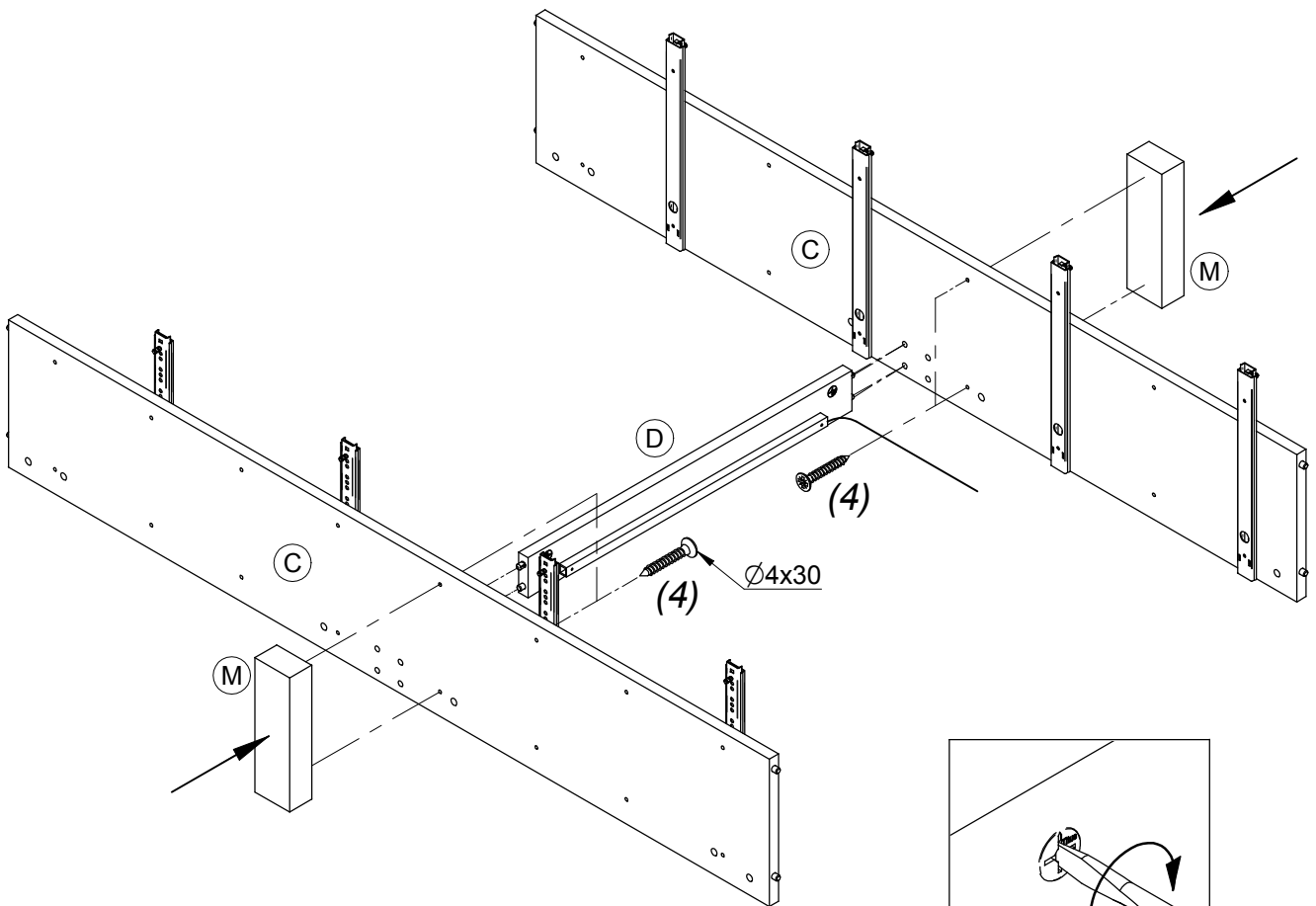
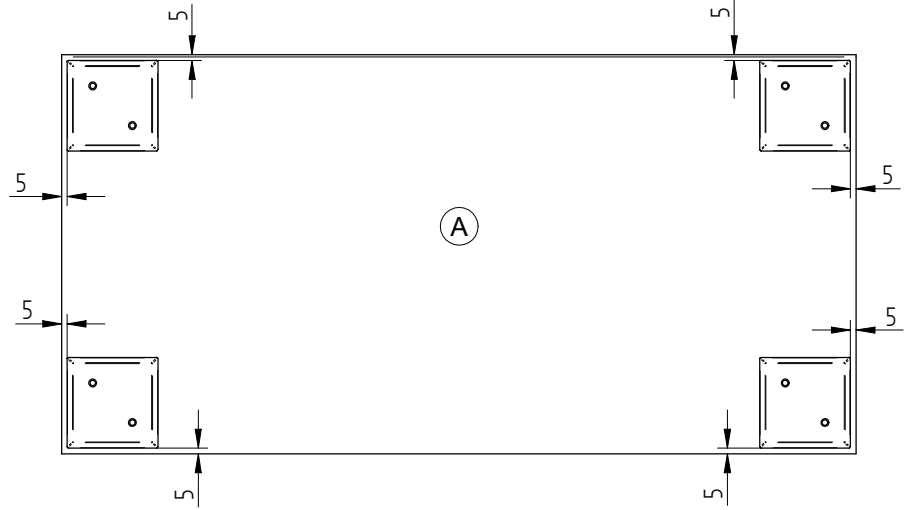
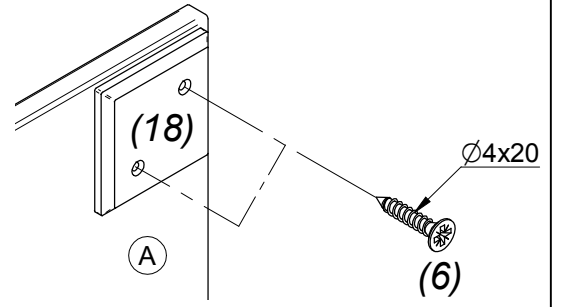
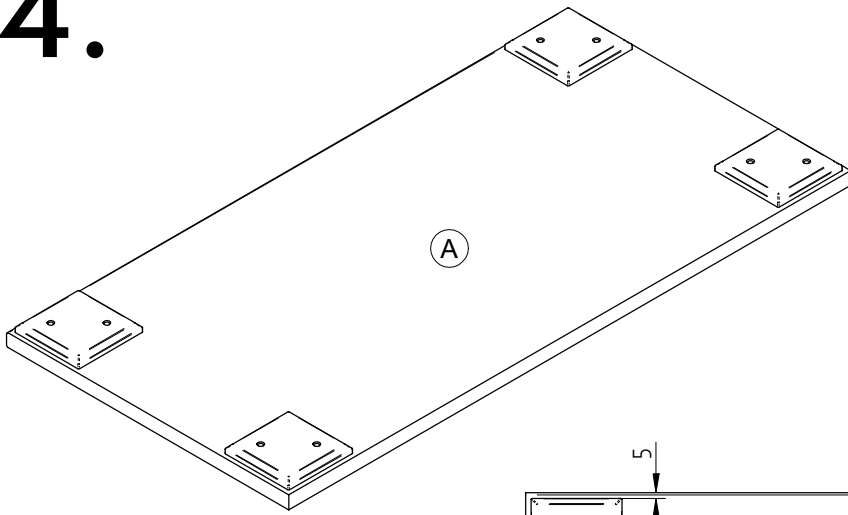

# 5.

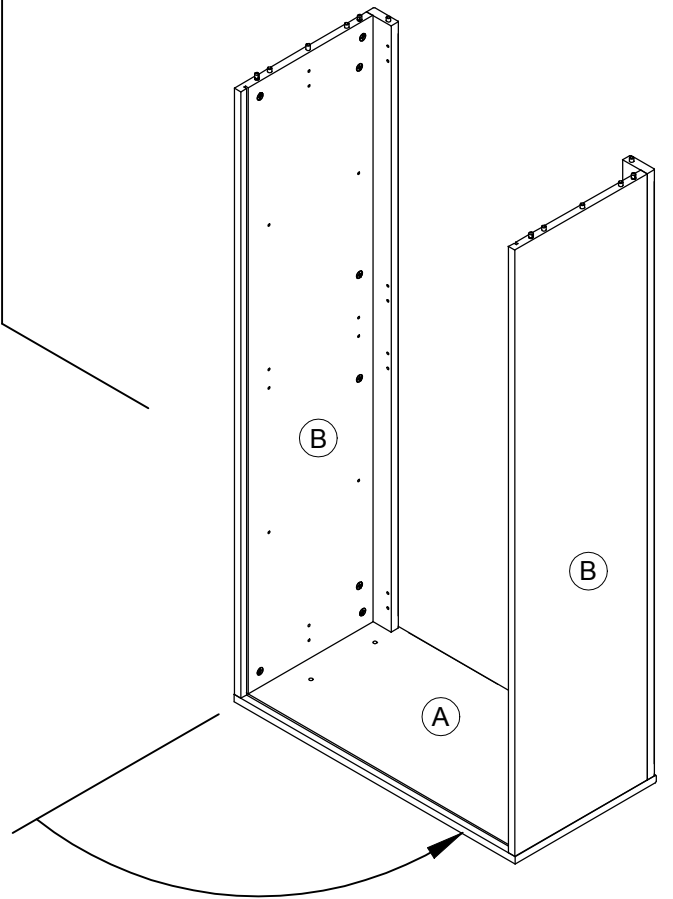
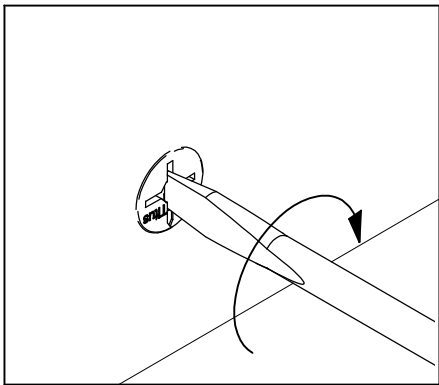
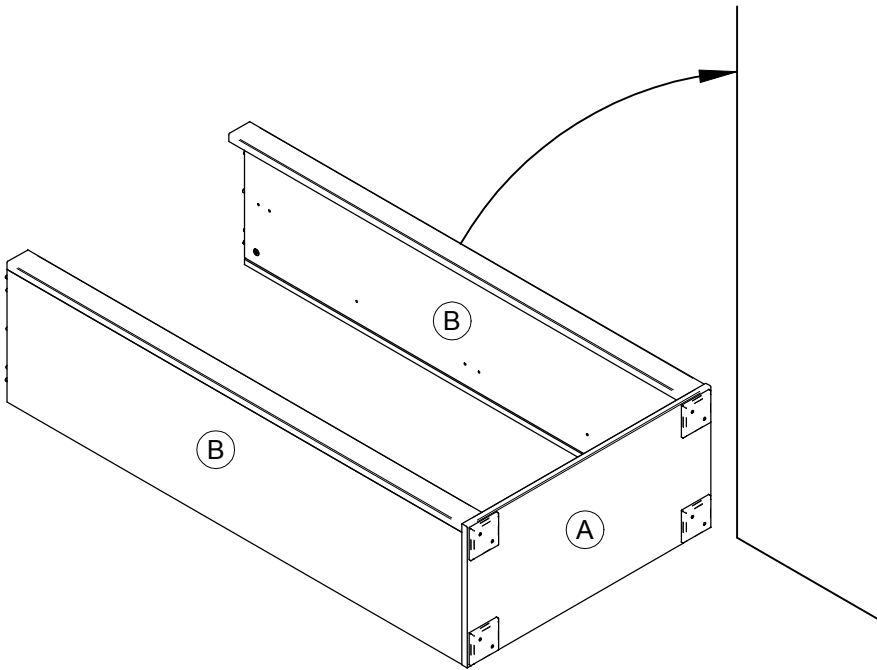
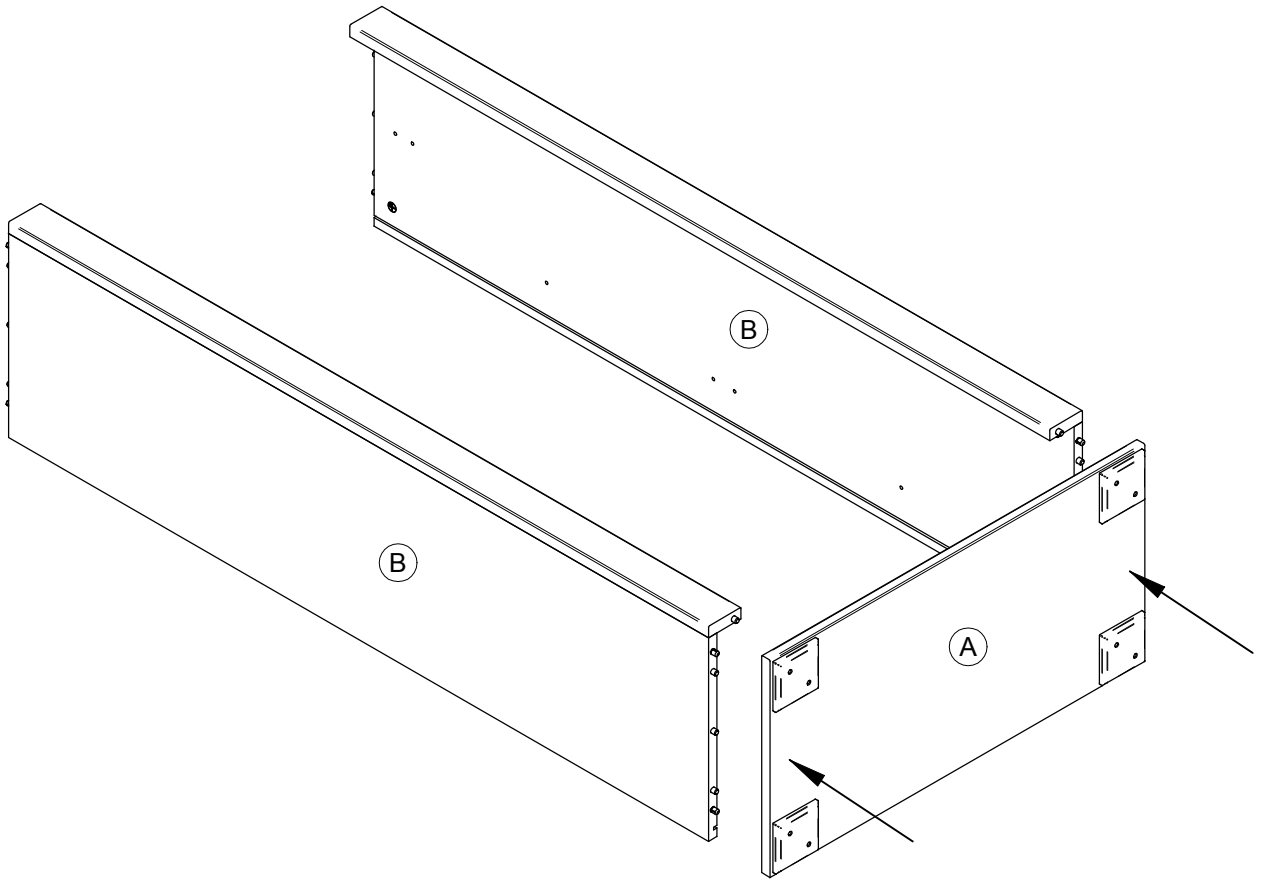

# 6.

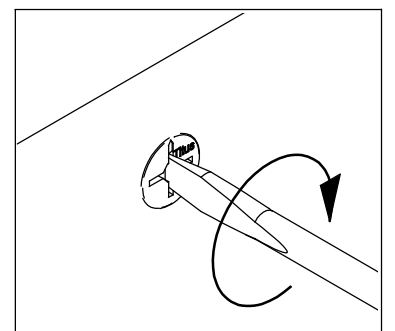
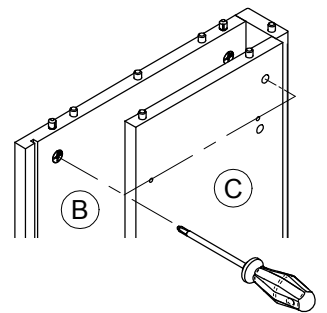
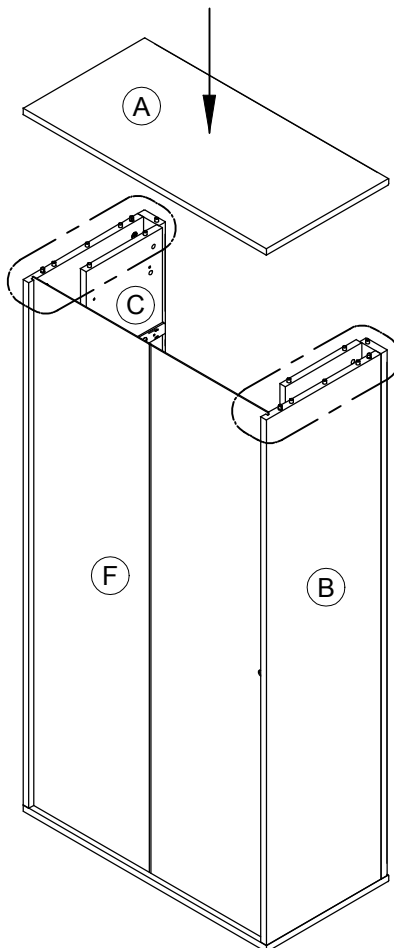
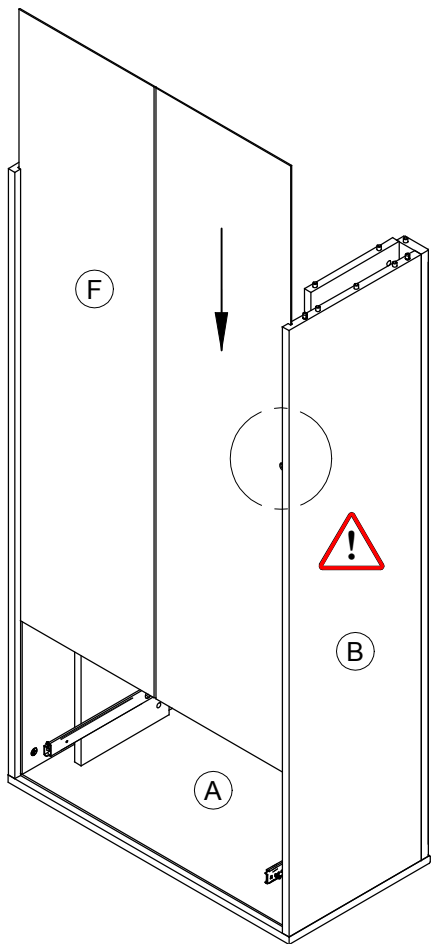
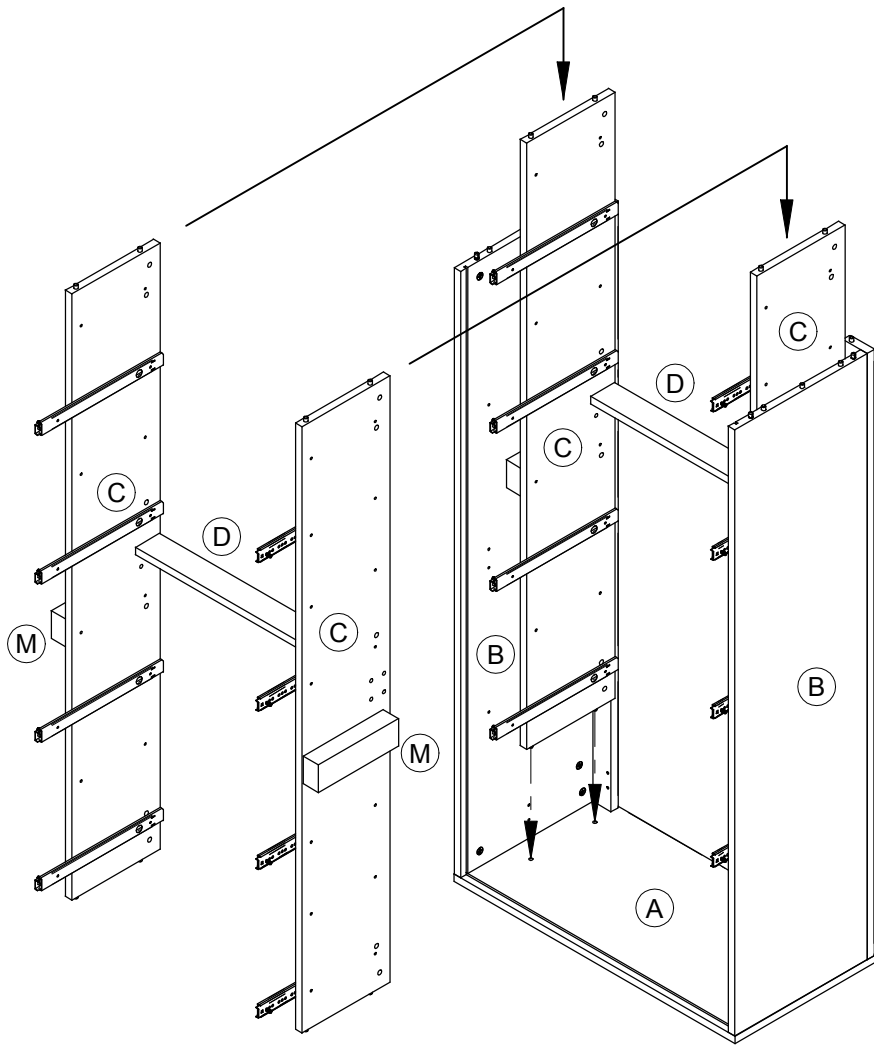



# 7.

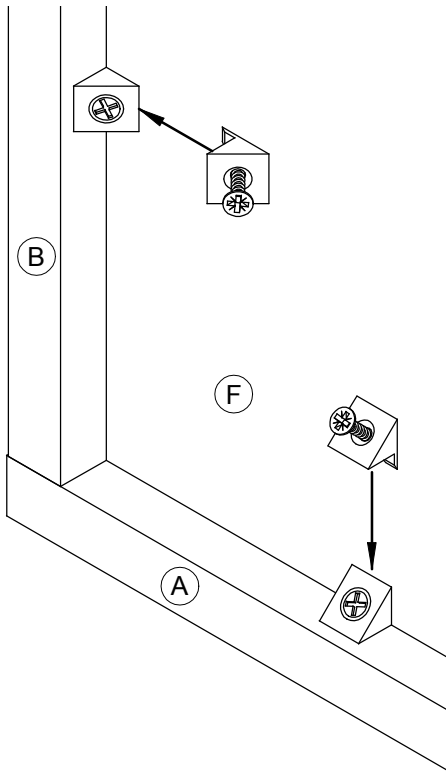

(12+13)

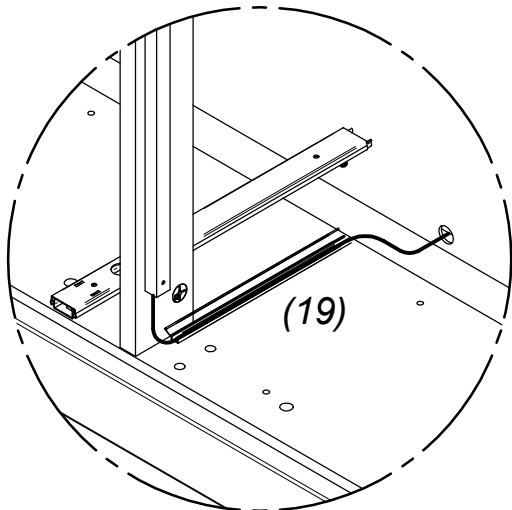
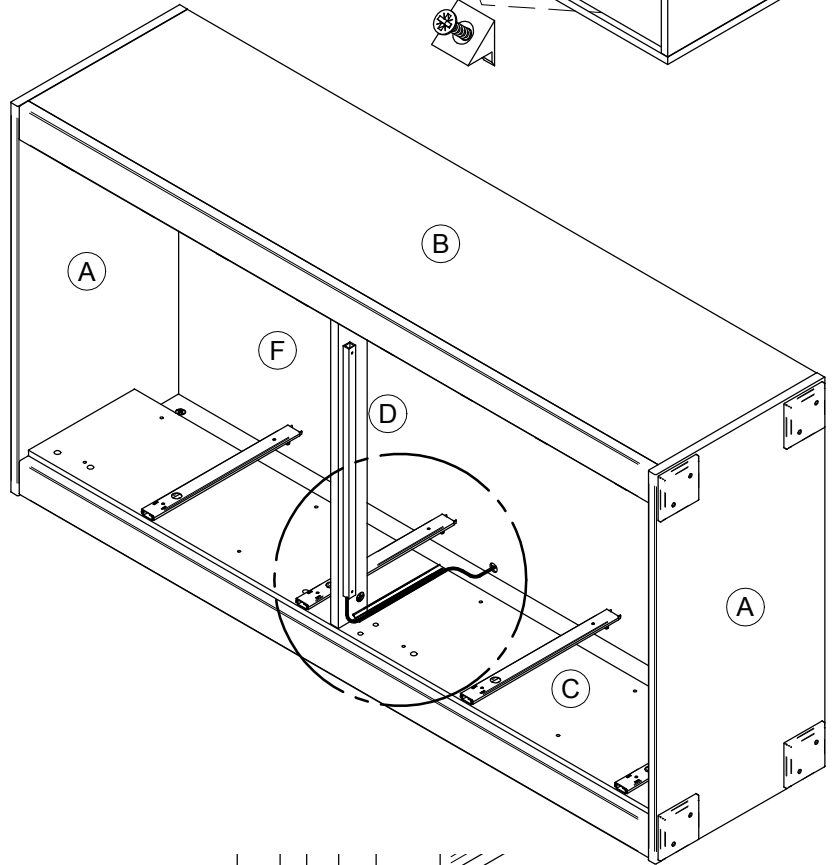
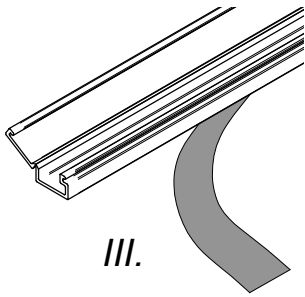
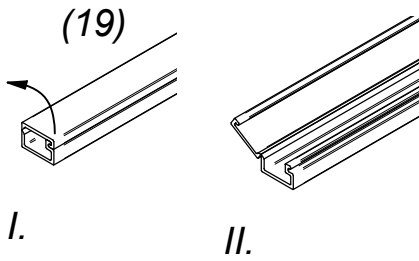
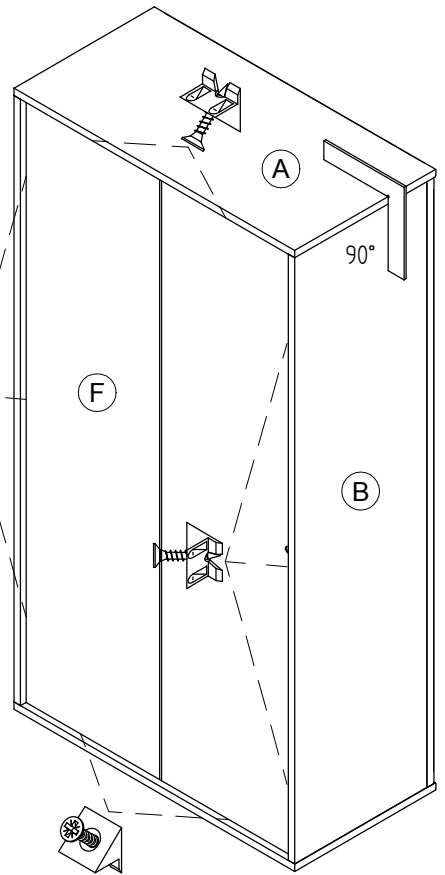

DETAIL

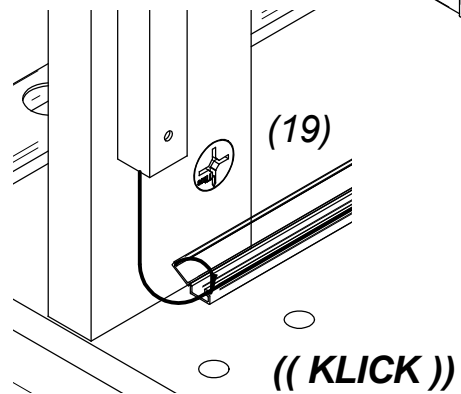

# 8.

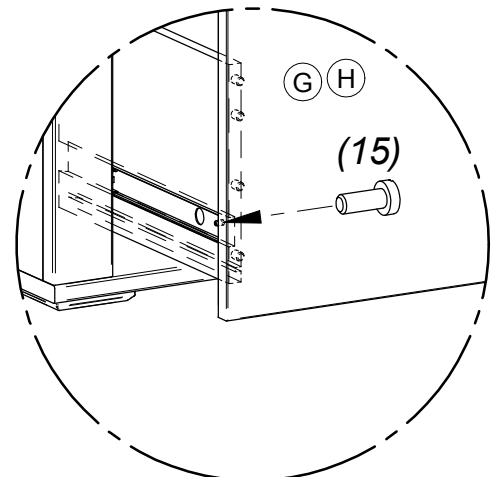
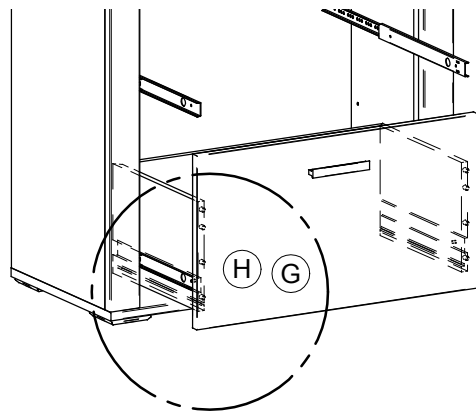
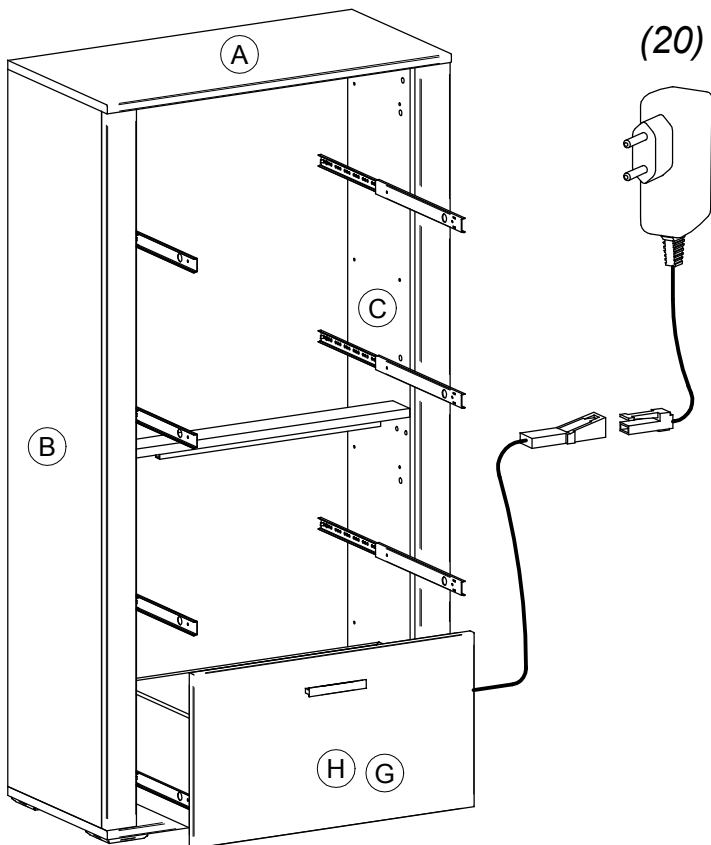
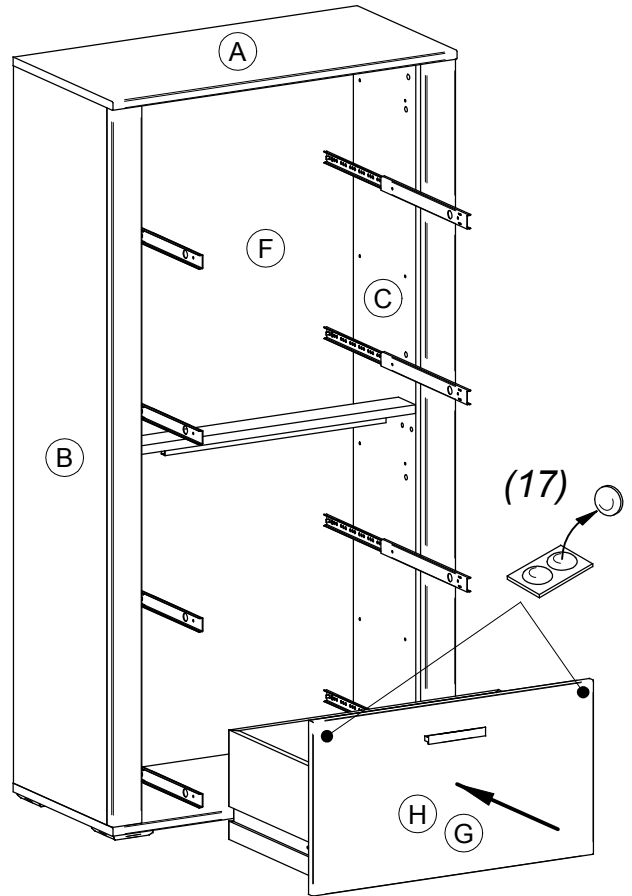
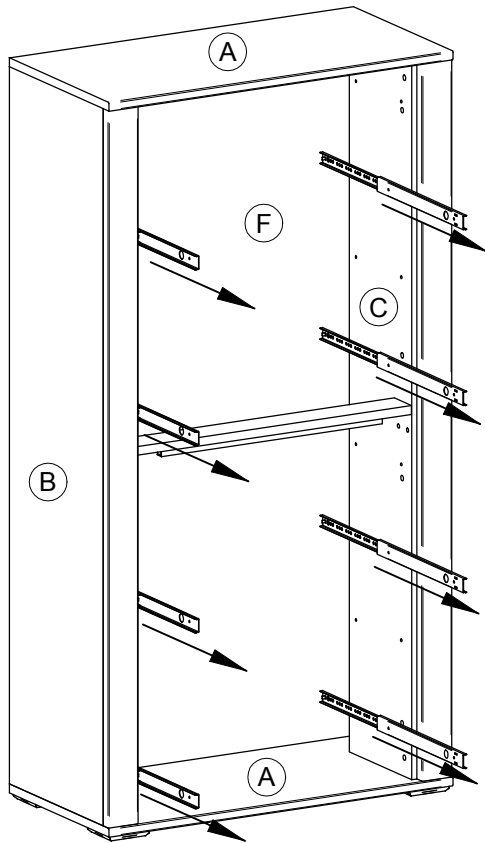

DETAIL

# 9.

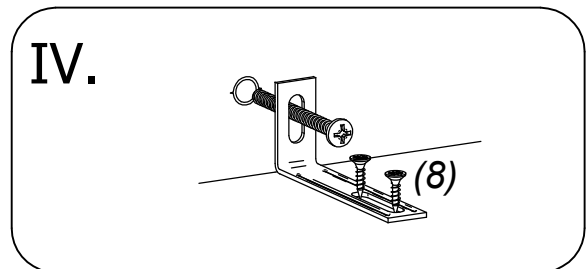
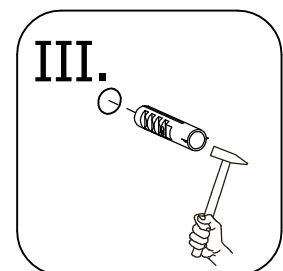
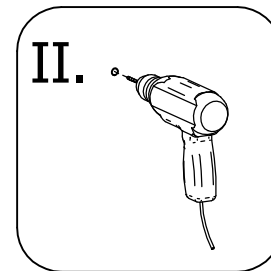
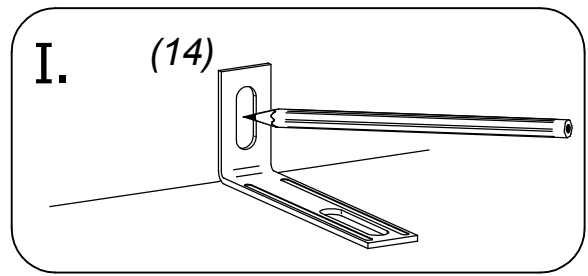
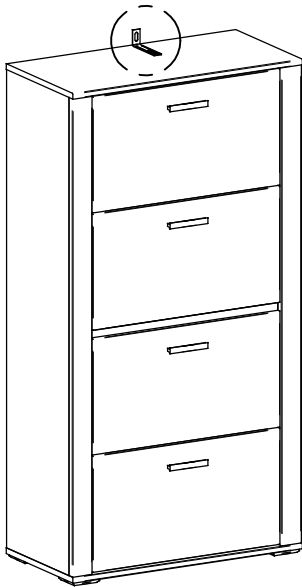





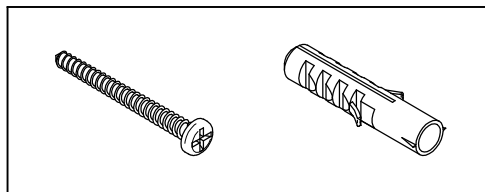



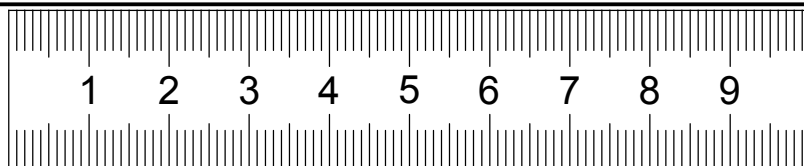
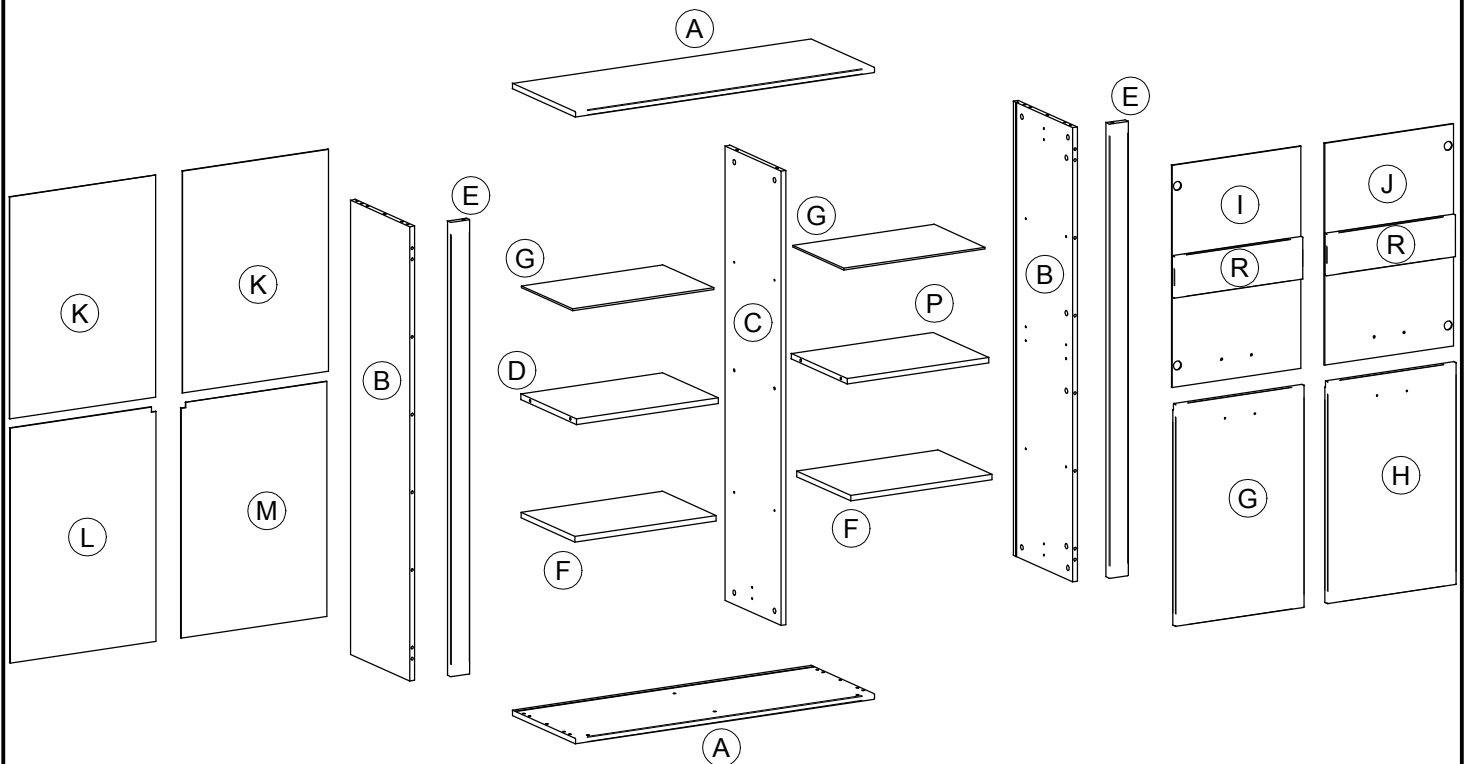
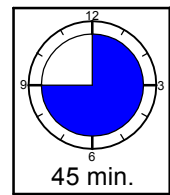
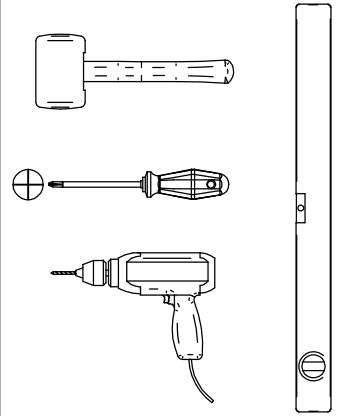
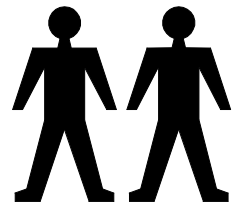
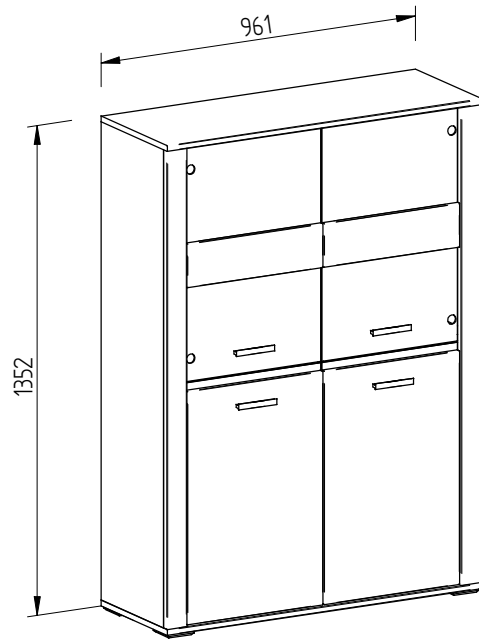

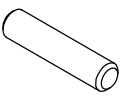
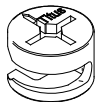
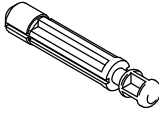
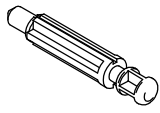



Wenn Möbelstücke umkippen, können ernste oder lebensgefährliche Verletzungen durch Einklemmen die Folge sein. Um zu verhindern, dass das Möbelstück umkippt, muss es fest an der Wand verankert werden. Beschläge für die Wandbefestigung sind nicht beige packt, da sie von der jeweiligen Wandbeschaffenheit abhängig sind. Befestigungsbeschläge benutzen, die für die heimischen Wände geeignet sind. Bei diesbezüglichen Fragen den örtlichen Fachhandel zu Rate ziehen.

Prevrhnutie nábytku môže spôsobiť vážne či smrteľné zranenia. Aby sa zabránilo prevrhnutiu nábytku, upevnite ho ku stene. Upevňovací materiál nie je súčasťou balenia, pretože na každý materiál steny je potrebné použiť iný typ skrutky a hmoždinky. Použite taký upevňovací materiál, ktorý je vhodný na konkrétny typ steny u vás doma. V prípade potreby sa poraďte s odborníkom.

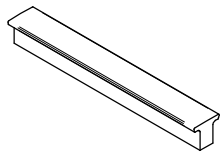
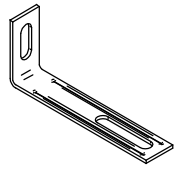
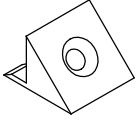

# BENO 06

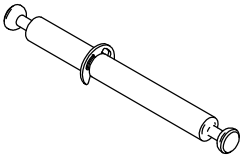
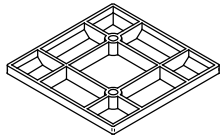
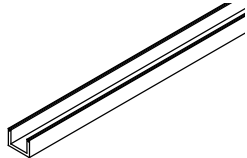
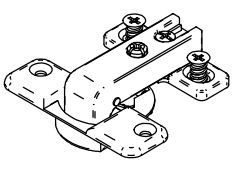
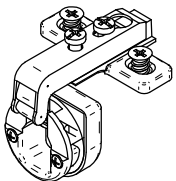
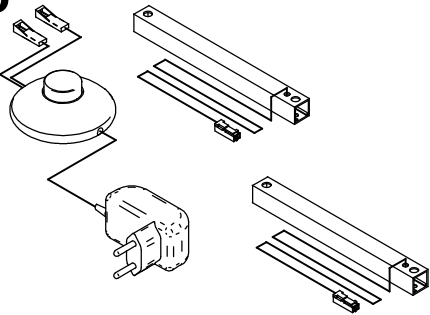
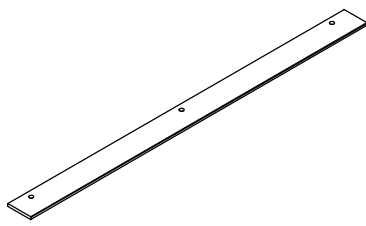

<b>1</b> $\varnothing 8 \times 35$ x26 	<b>2</b> $\varnothing 15$ x30 	<b>3</b> $\varnothing 8$ x22 	<b>4</b> $\varnothing 5$ x4 	<b>5</b> $\varnothing M4 \times 20$ x4 
<b>6</b> $\varnothing M4 \times 10$ x4 	<b>7</b> $\varnothing 6,5$ x10 	<b>8</b> $\varnothing 3,5 \times 15$ x10 	<b>9</b> $\varnothing 4 \times 20$ x10 	<b>10</b> $\varnothing 6,5$ x4 
<b>11</b> $\varnothing 5$ x8 	<b>12</b> $\varnothing 5$ x8 	<b>13</b> x4 	<b>14</b> x1 	<b>15</b> x12 
<b>16</b> $\varnothing 3,5 \times 20$ x27 	<b>17</b> x15 	<b>18</b> x2 	<b>19</b> $\varnothing M4 \times 15$ x10 	<b>20</b> $\varnothing 3 \times 25$ x4 
<b>21</b> $\varnothing 8$ x2 	<b>22</b> x5 	<b>23</b> x2 	<b>24</b> x4 	<b>25</b> x4 
<b>26</b> x1 		<b>27</b> x2 		

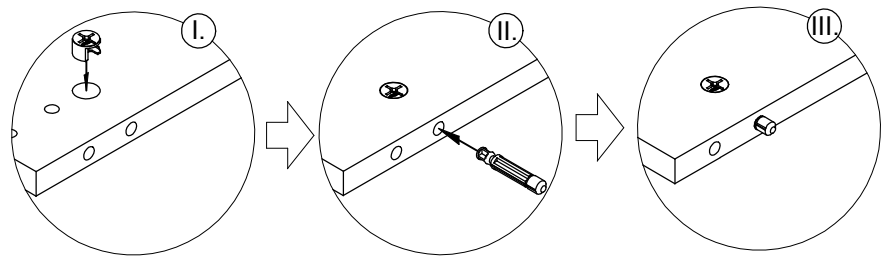
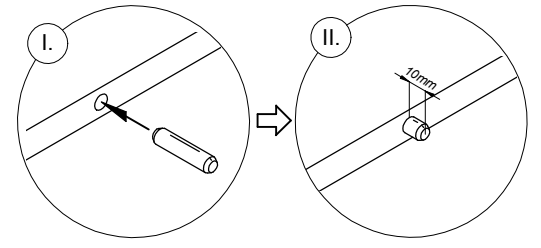

# 1.

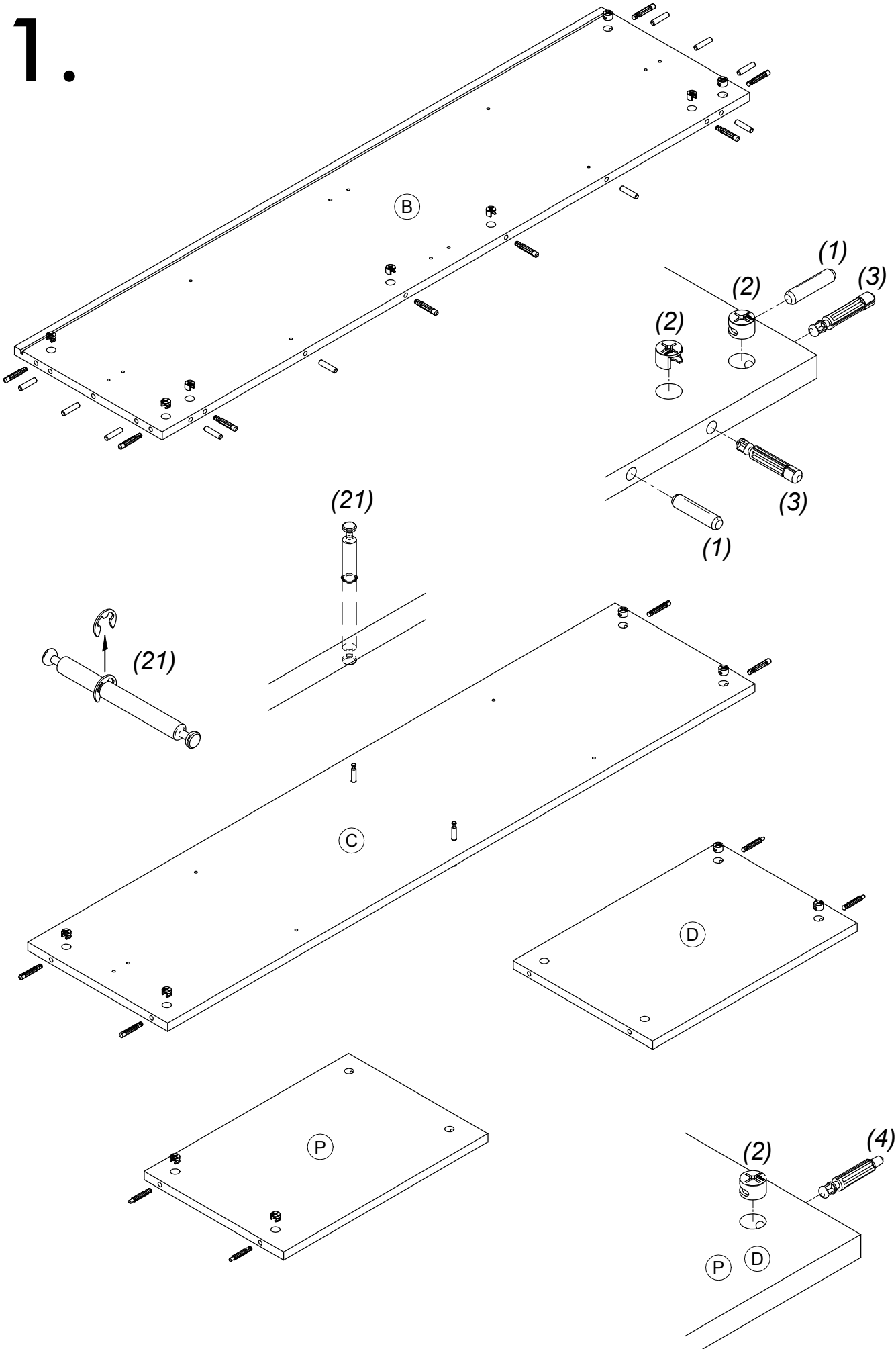

# 2.

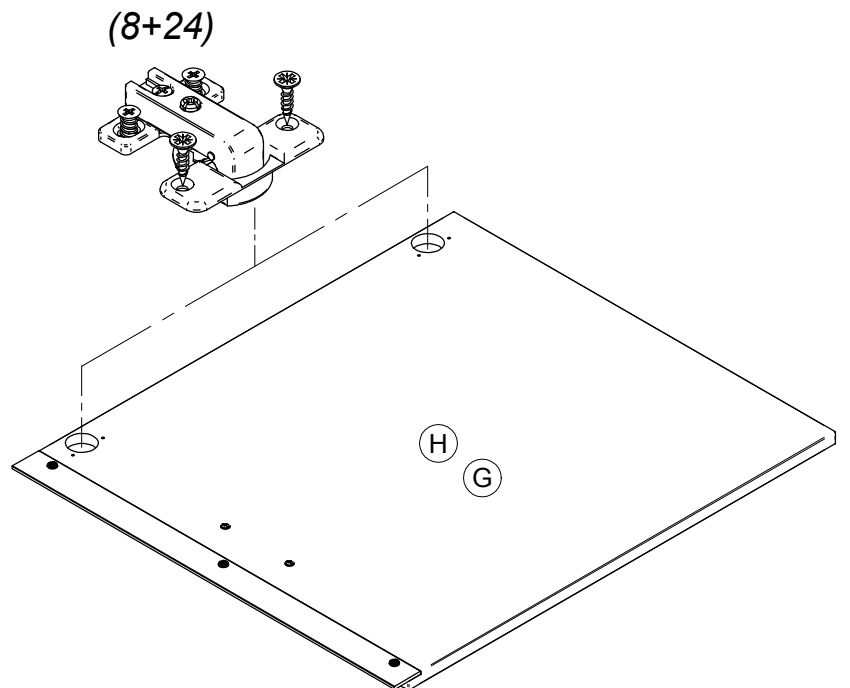
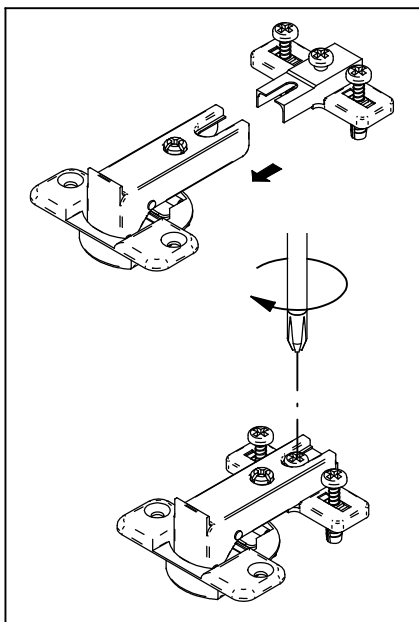
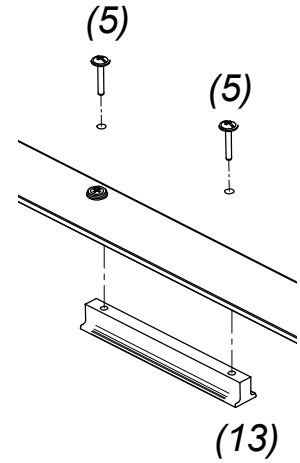
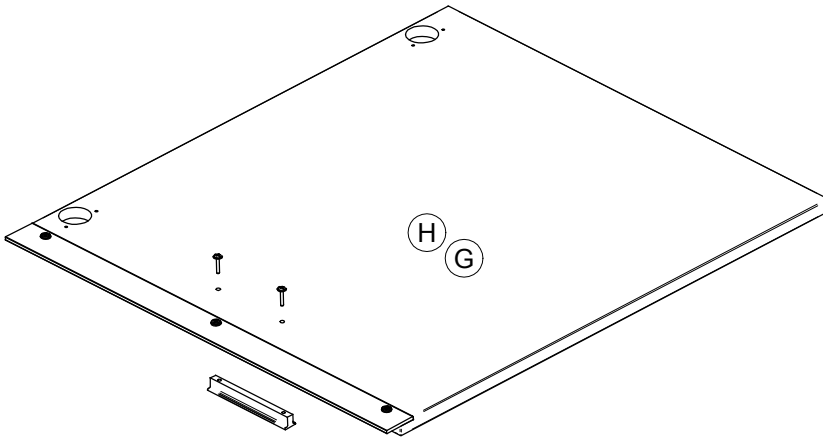
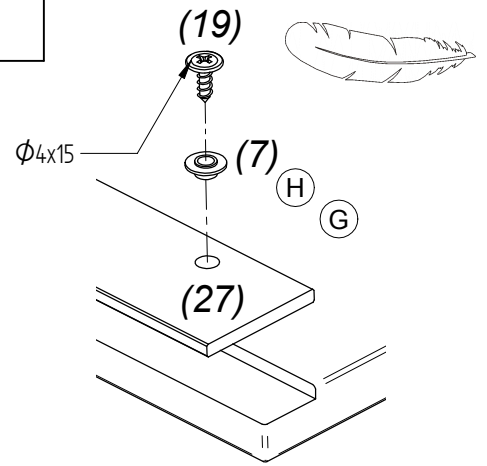
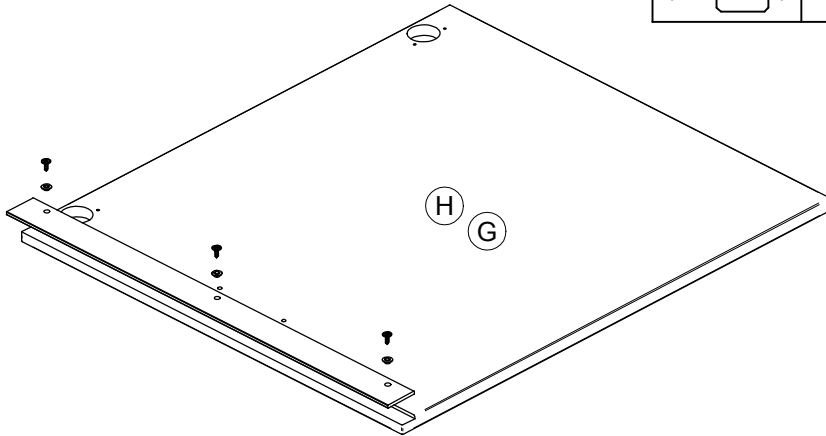
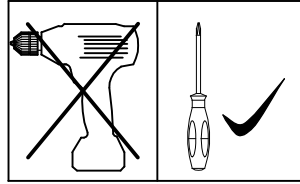

# 3.

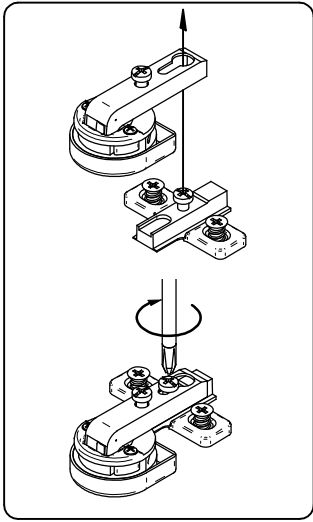

**A**

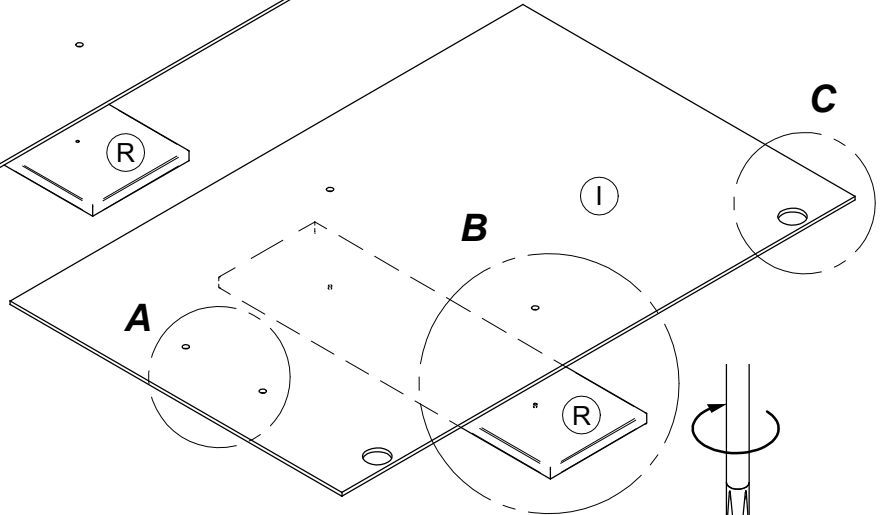
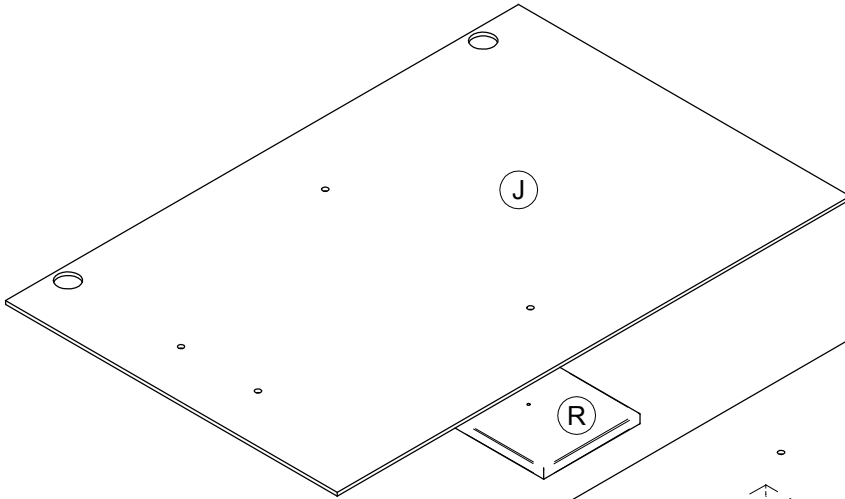
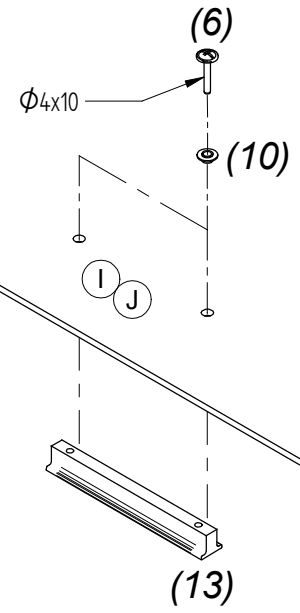

**B**

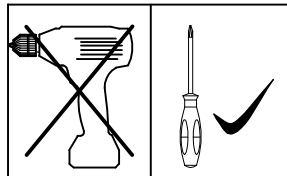
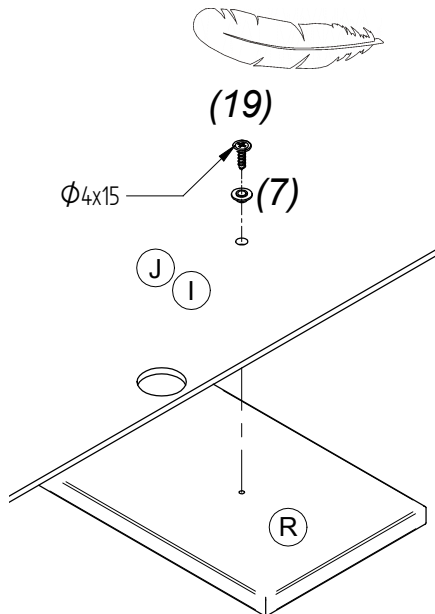

**C**

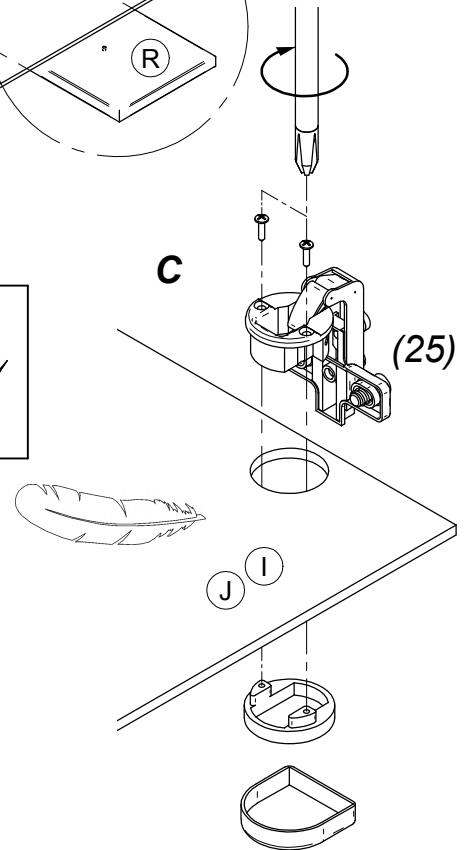



# 4.

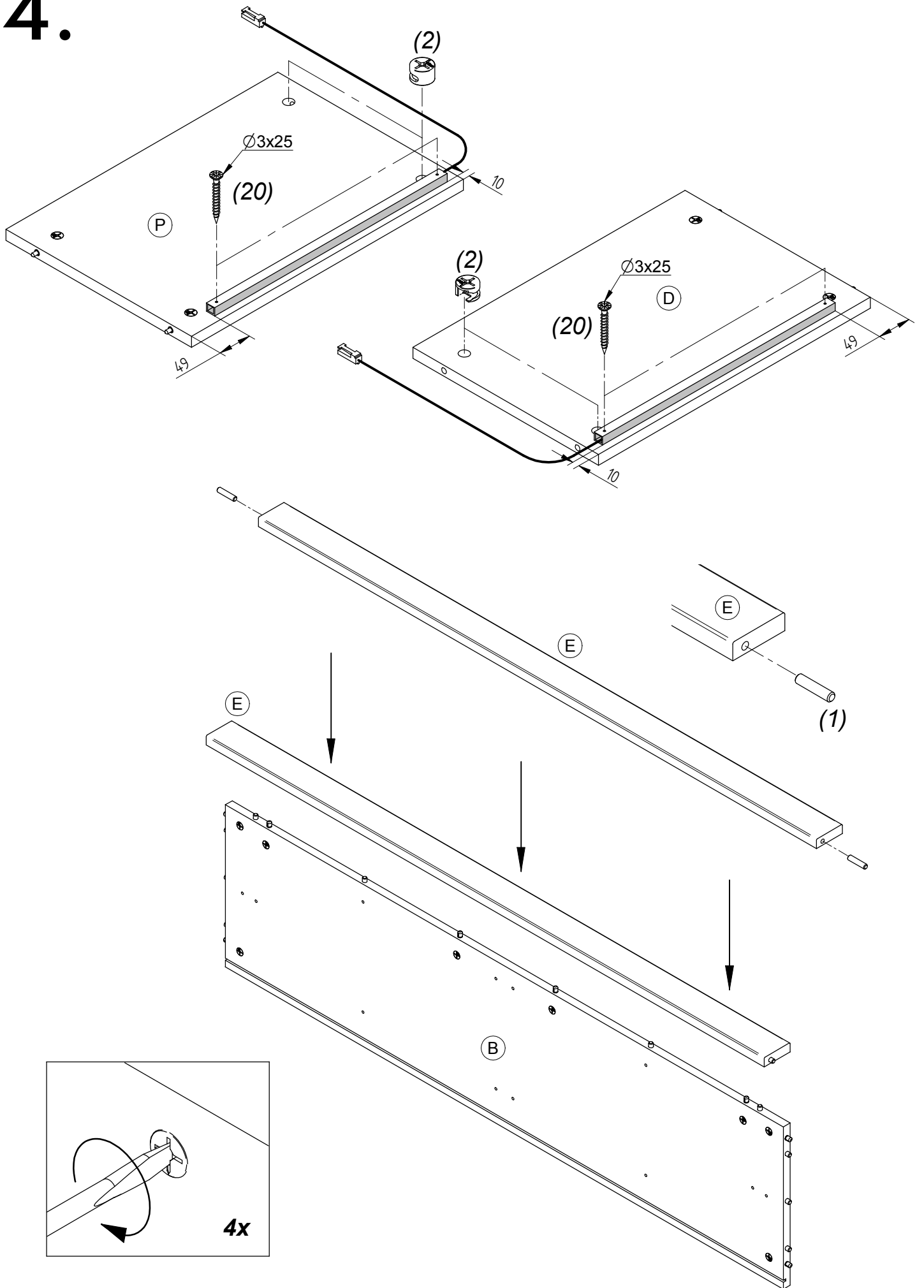

# 5.

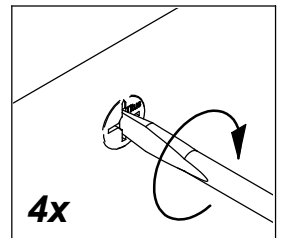
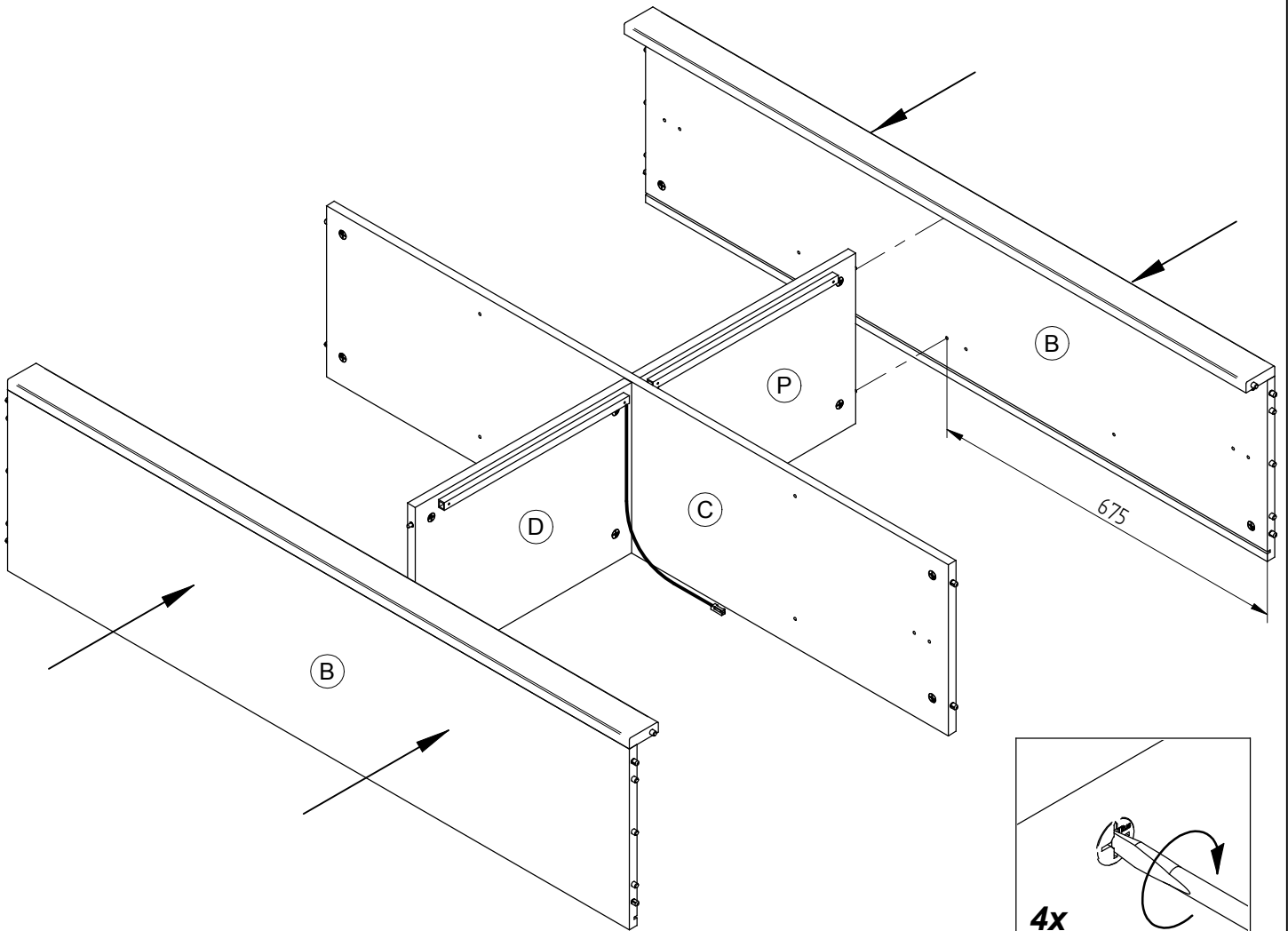
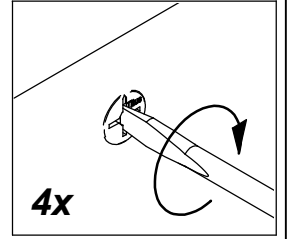
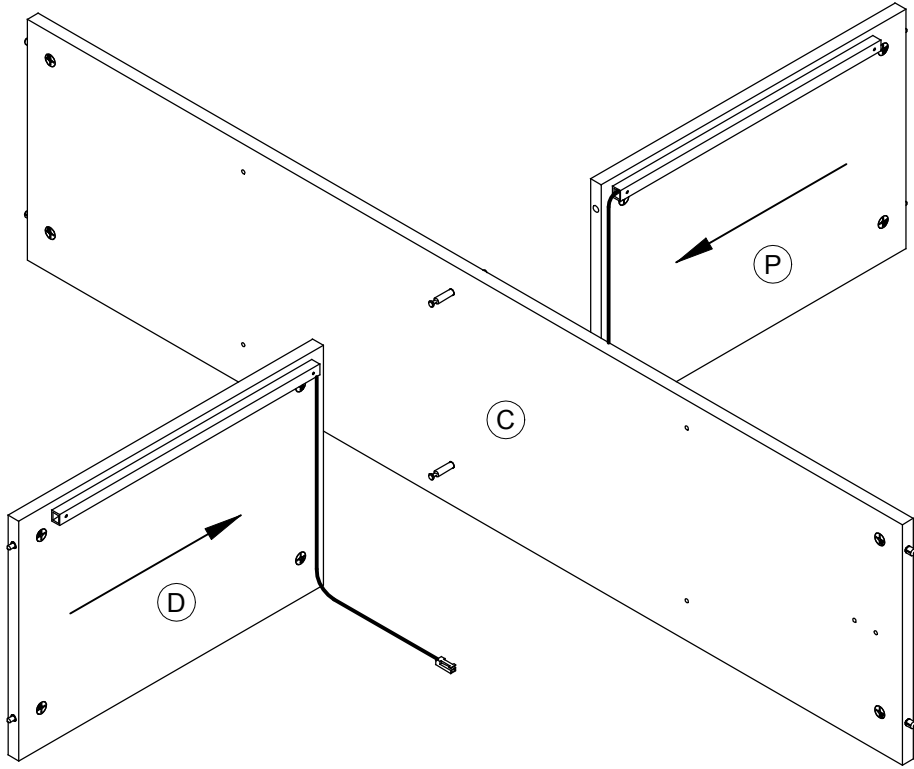

# 6.

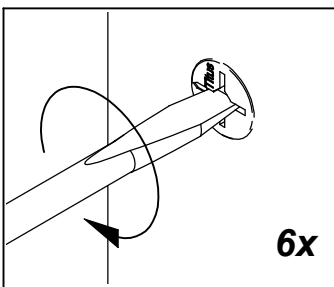
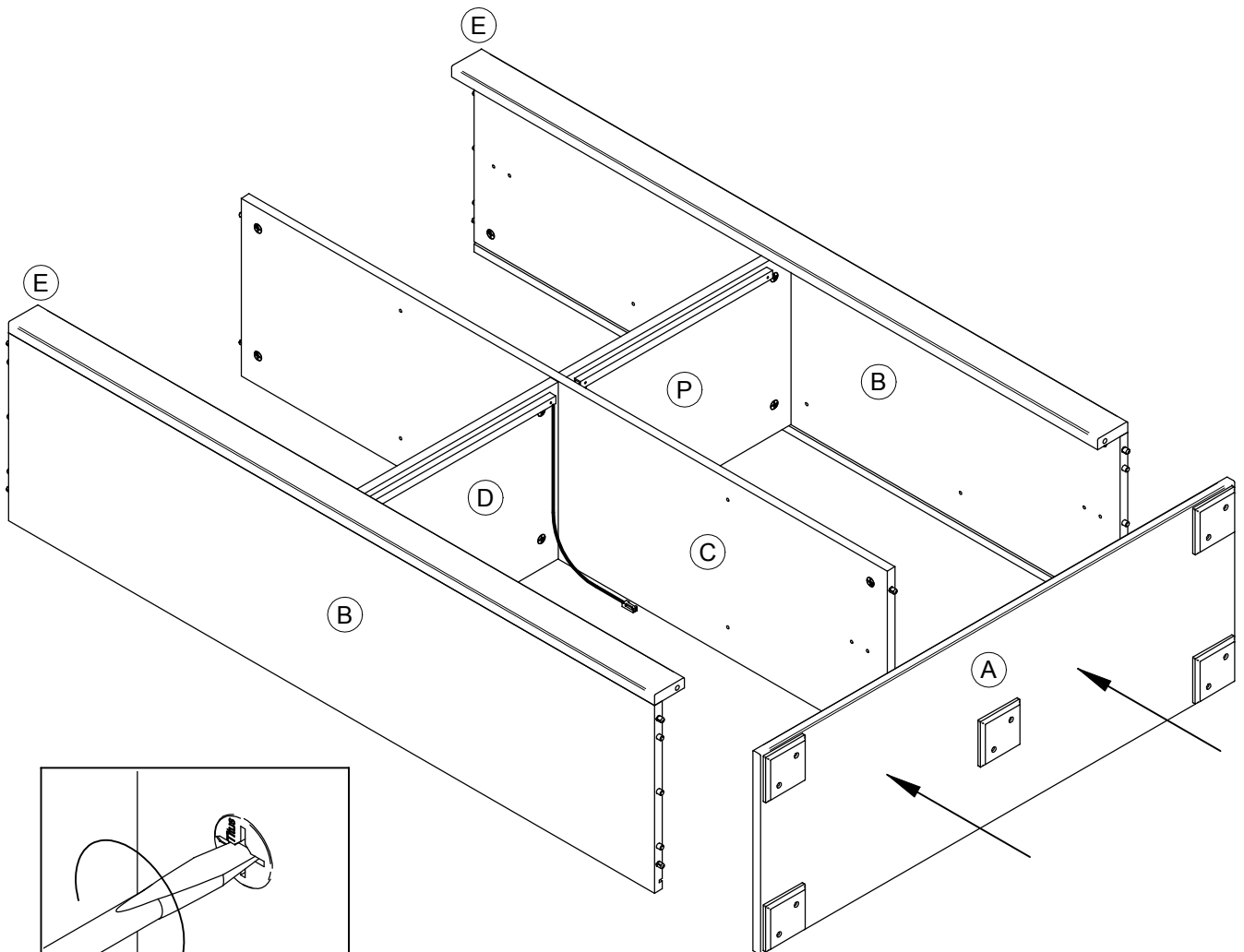
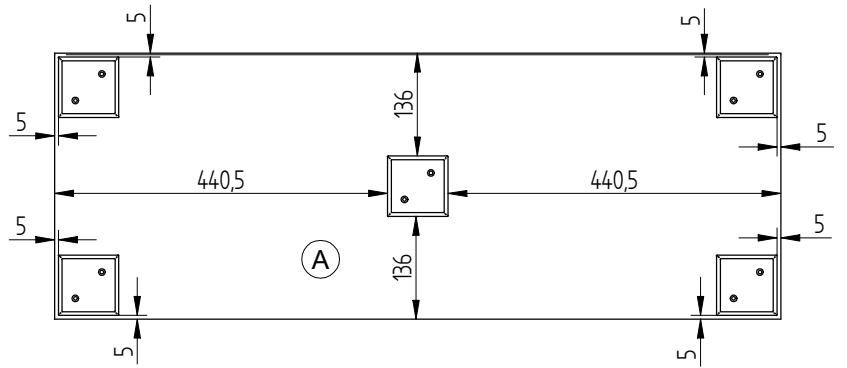
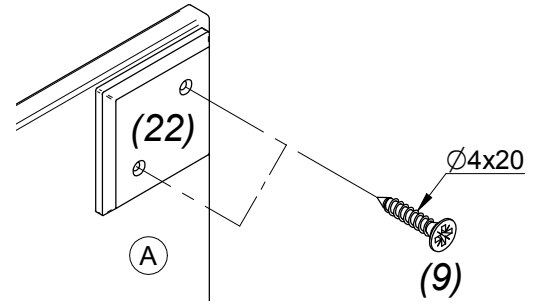
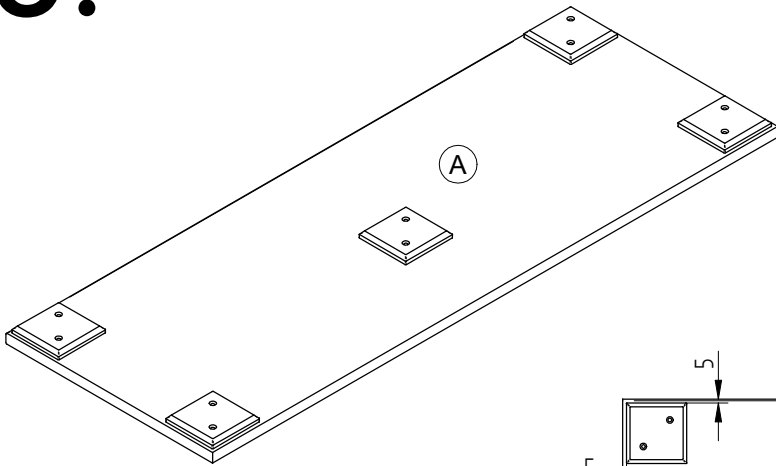

# 7.

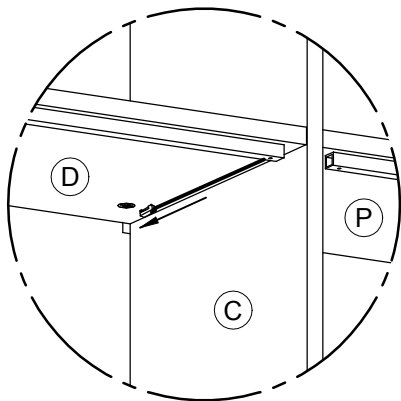
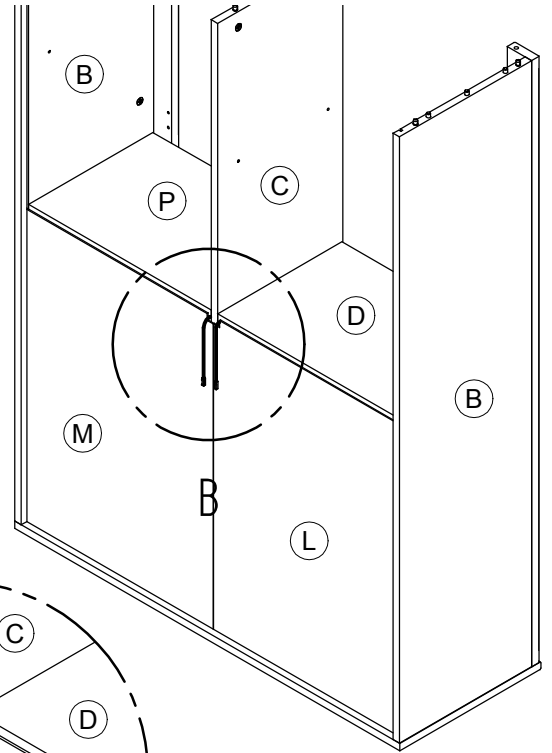
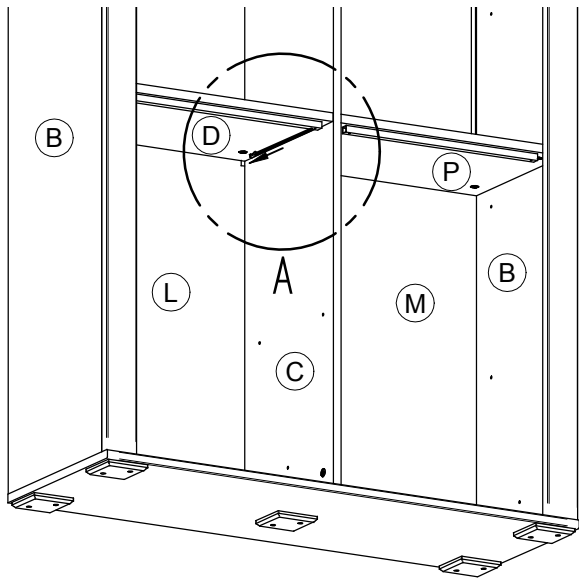
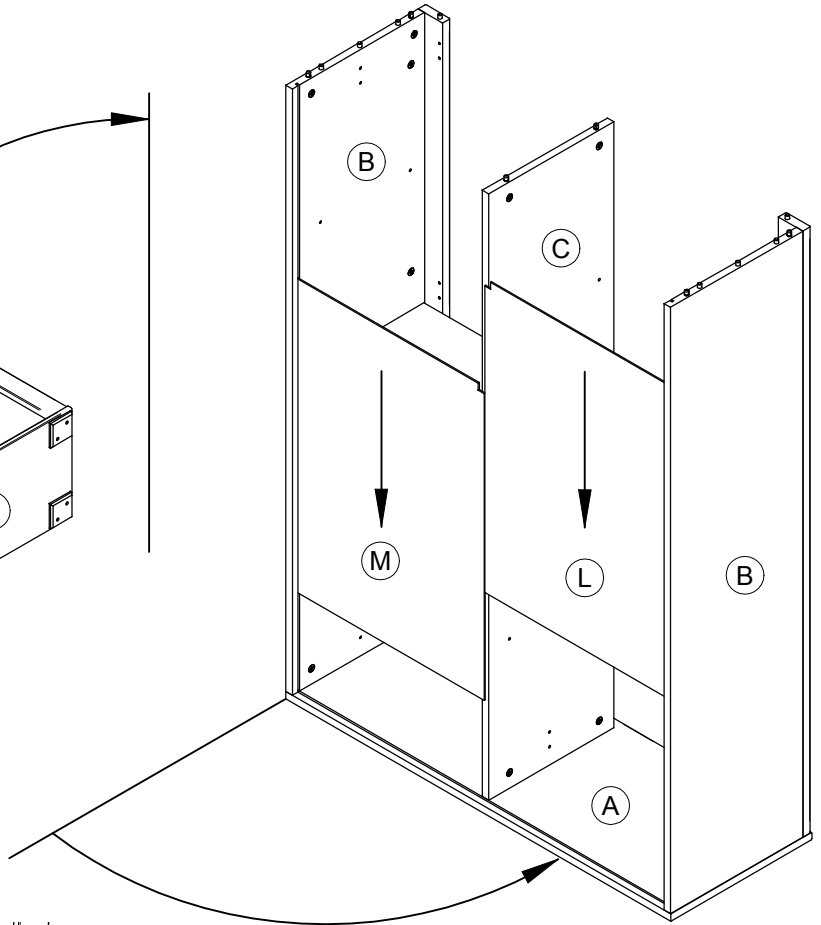
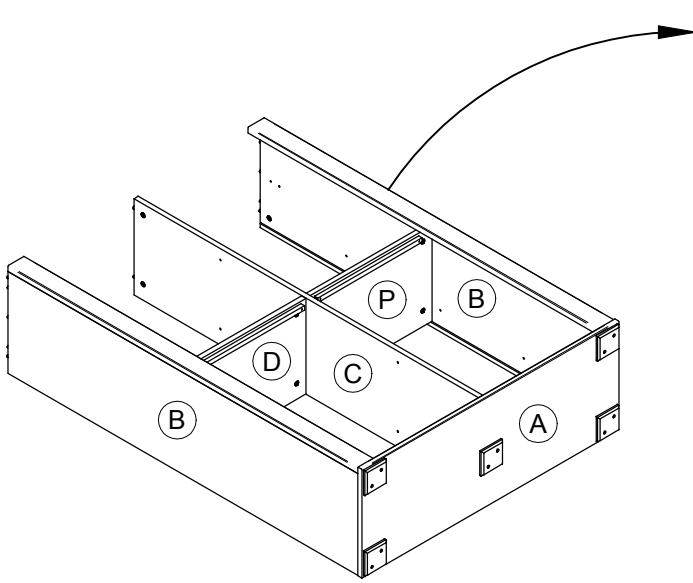

DETAIL A

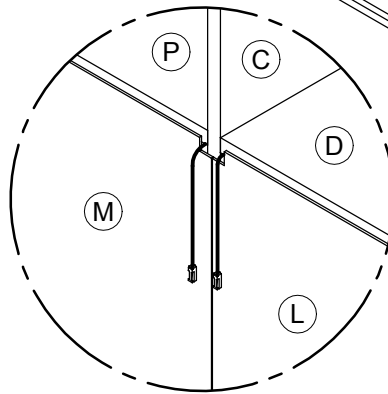

DETAIL B

# 8.

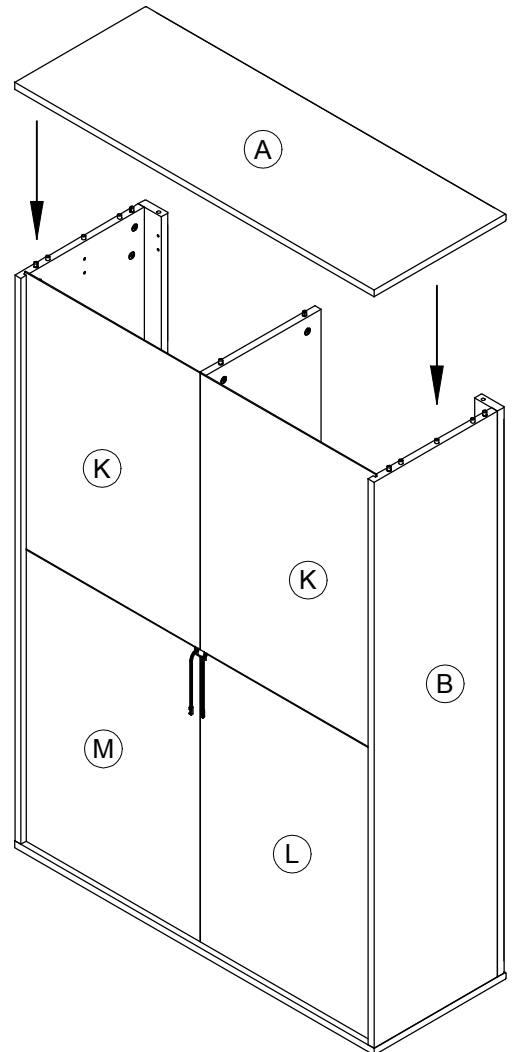
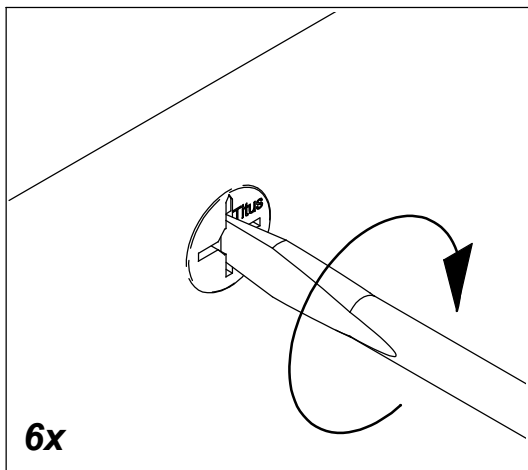
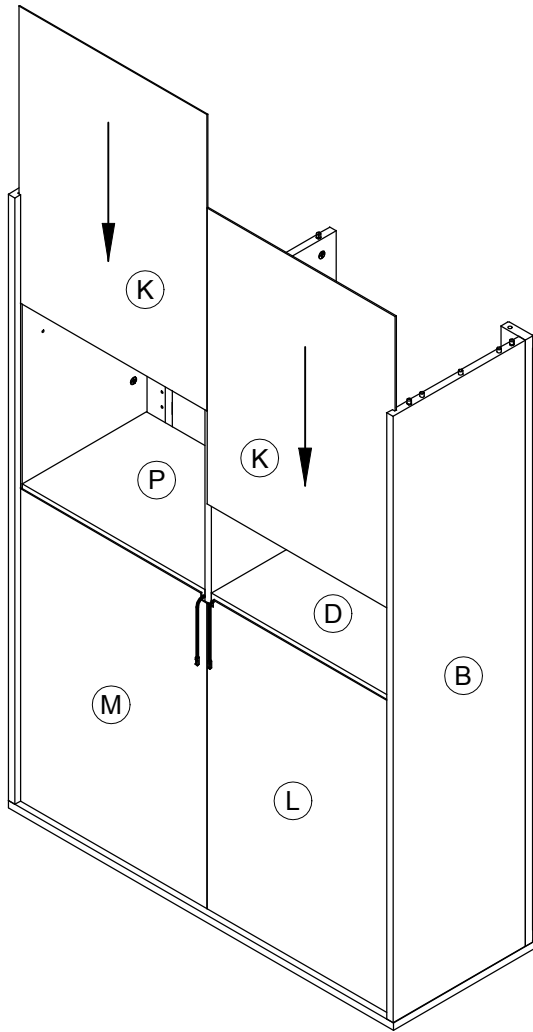

# 9.

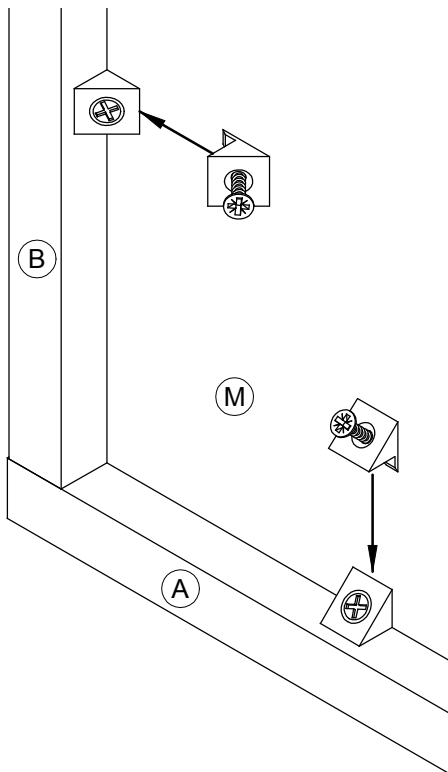
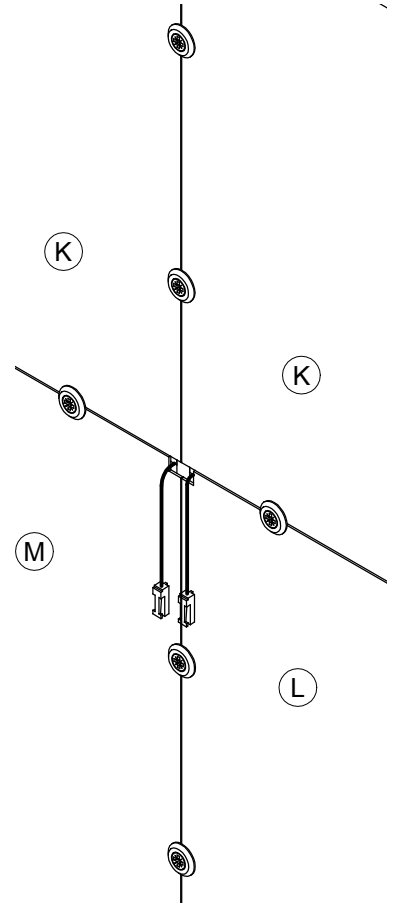
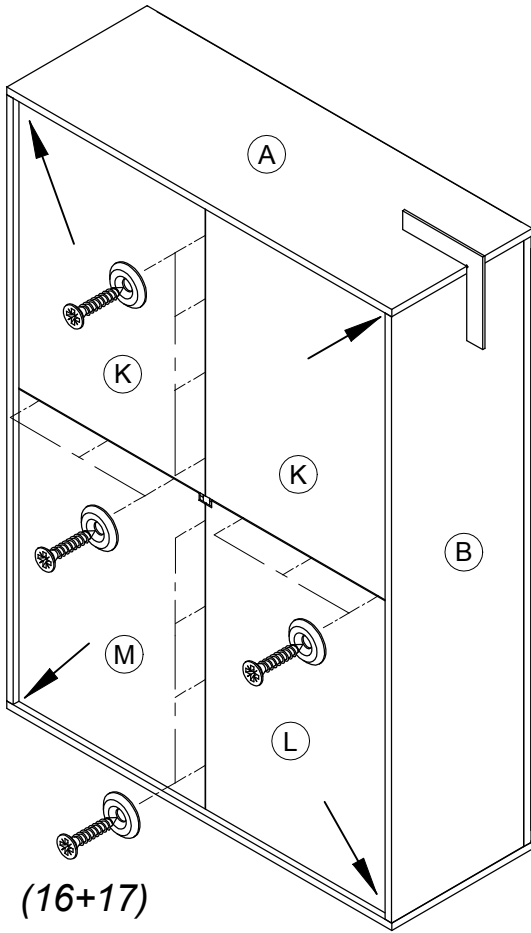

(15+16)

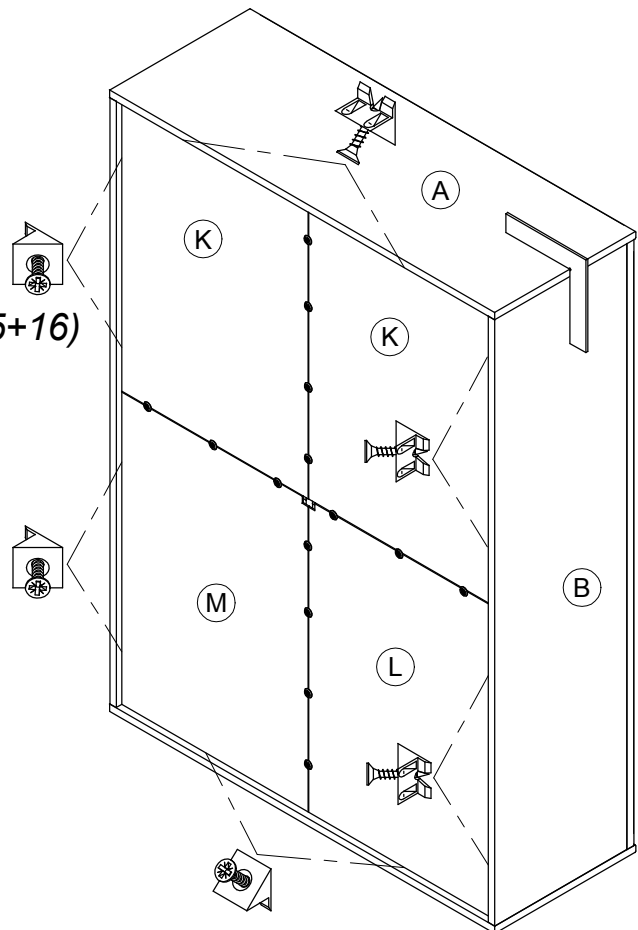

# 10.

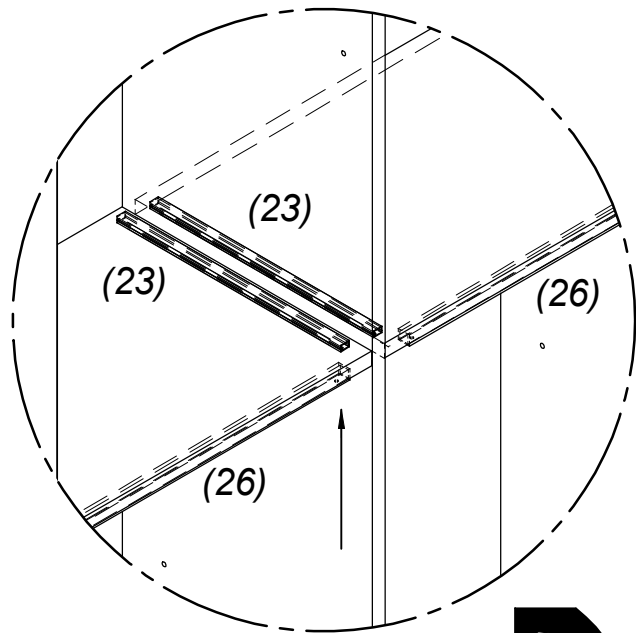
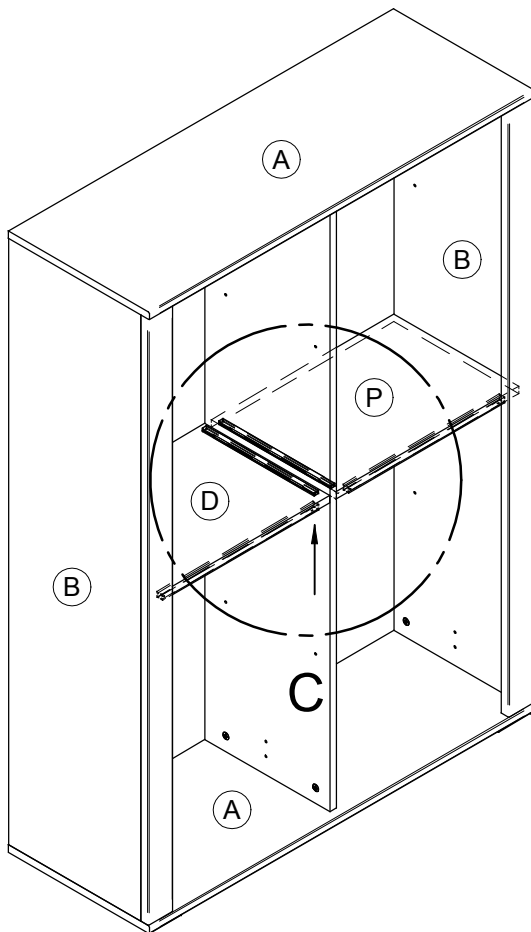
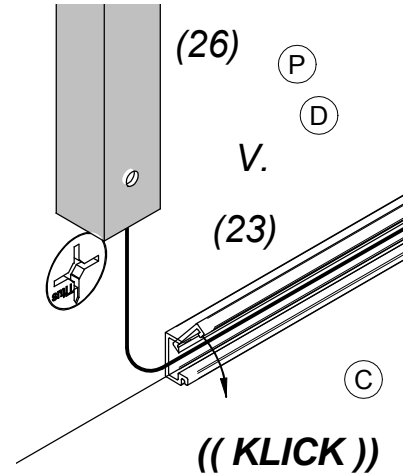
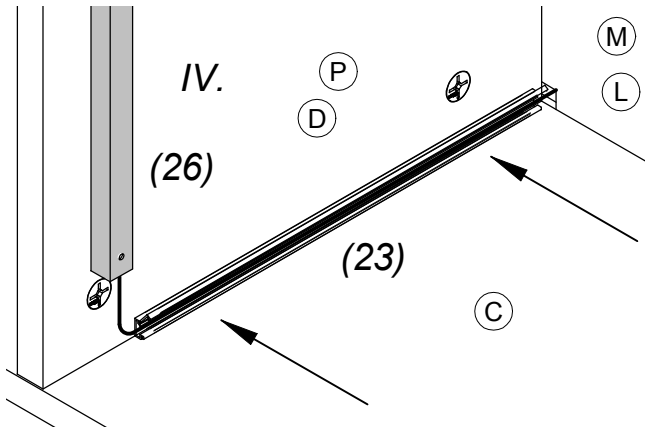
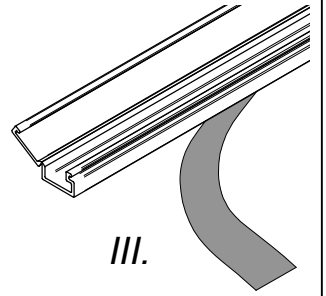
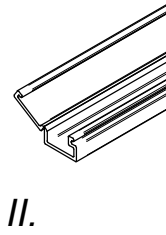
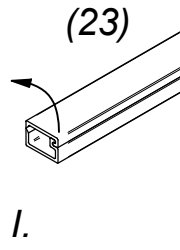
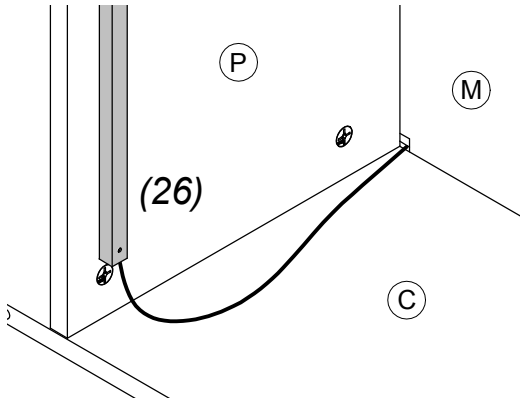

DETAIL C



# 11.

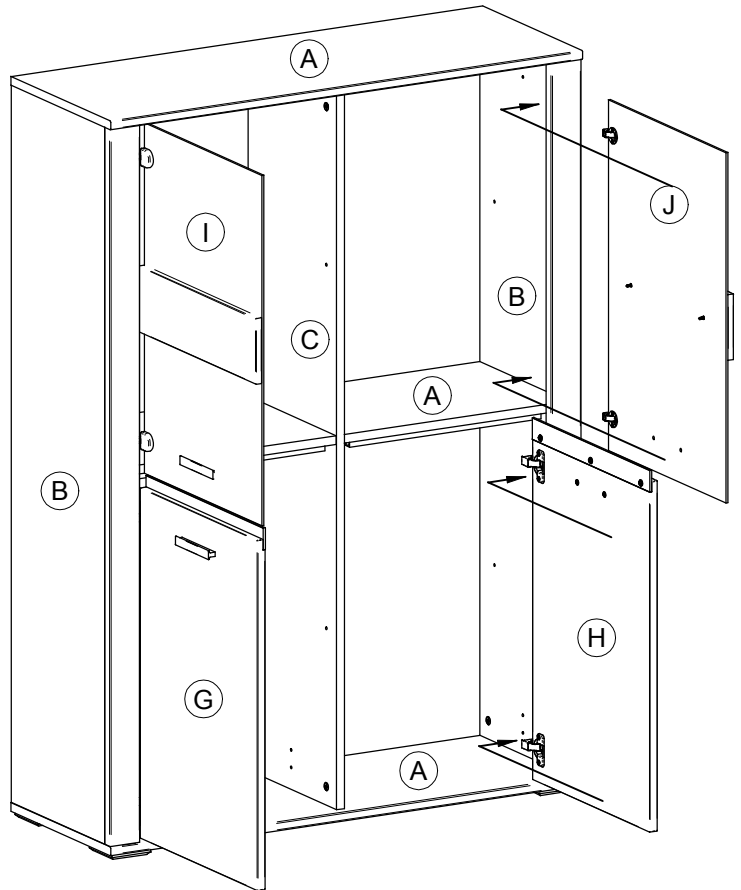
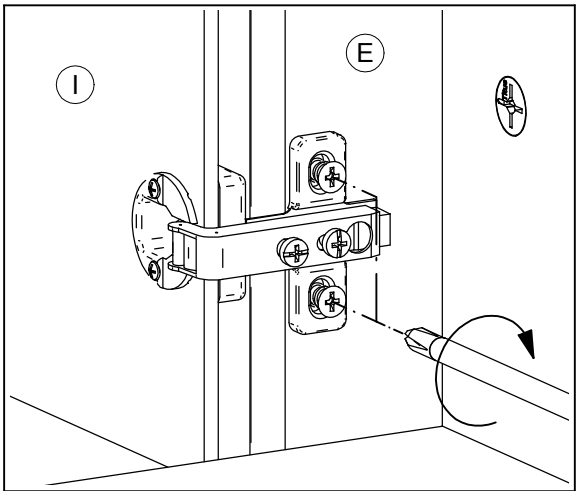
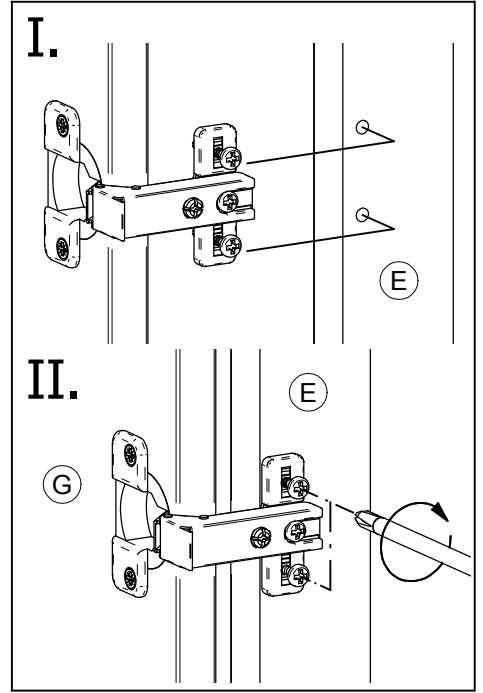
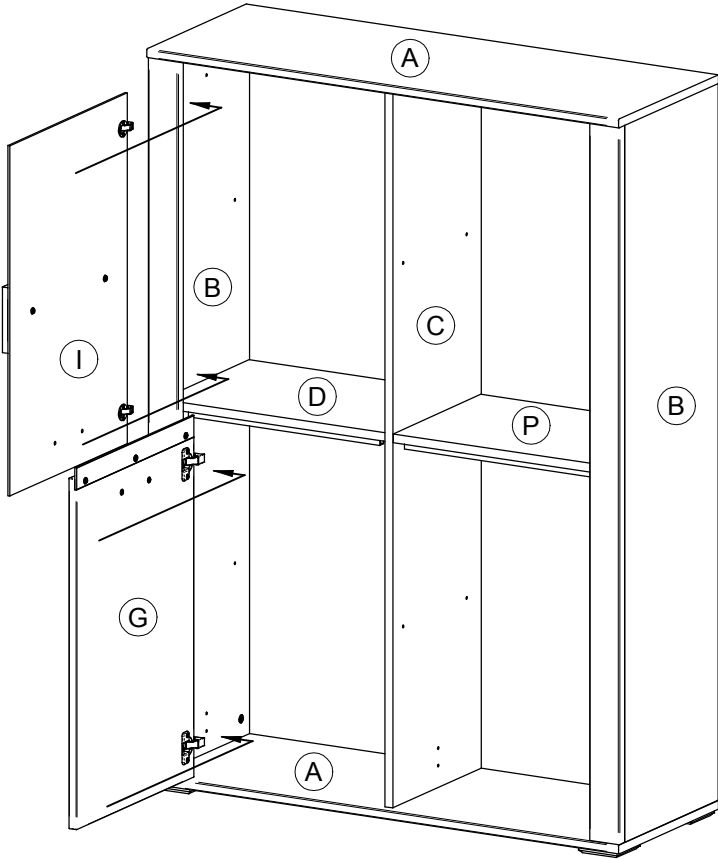



# 12.

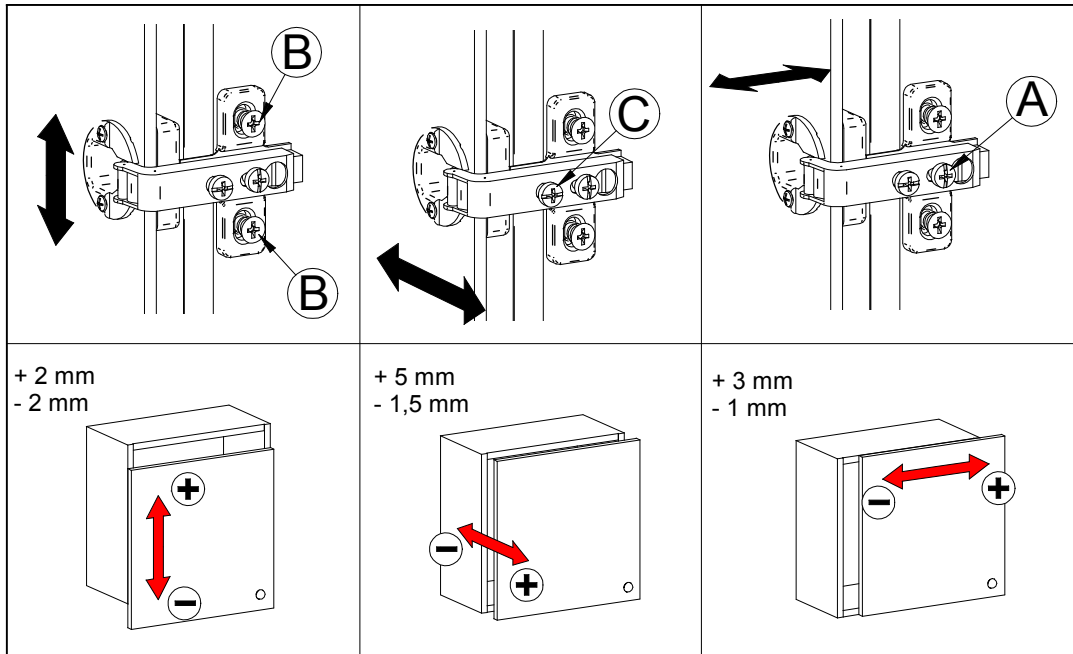
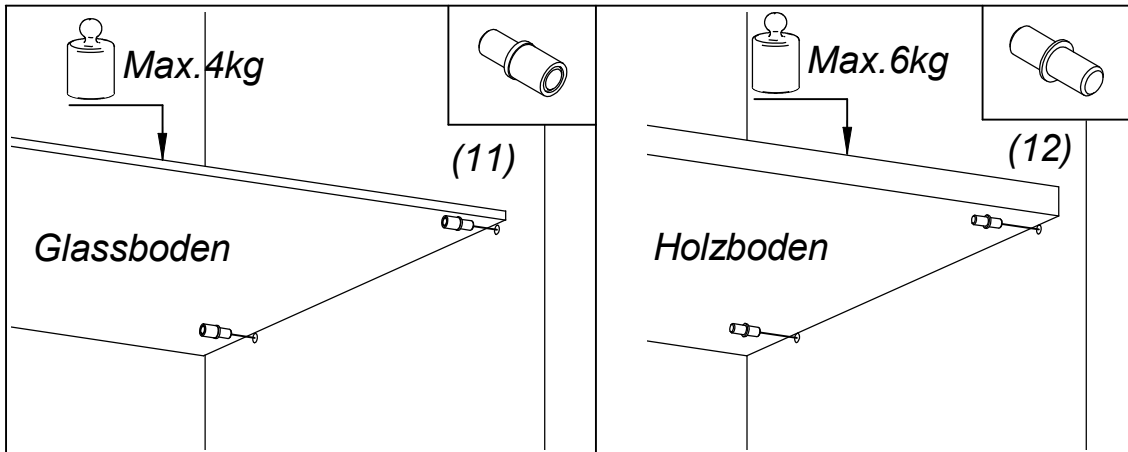
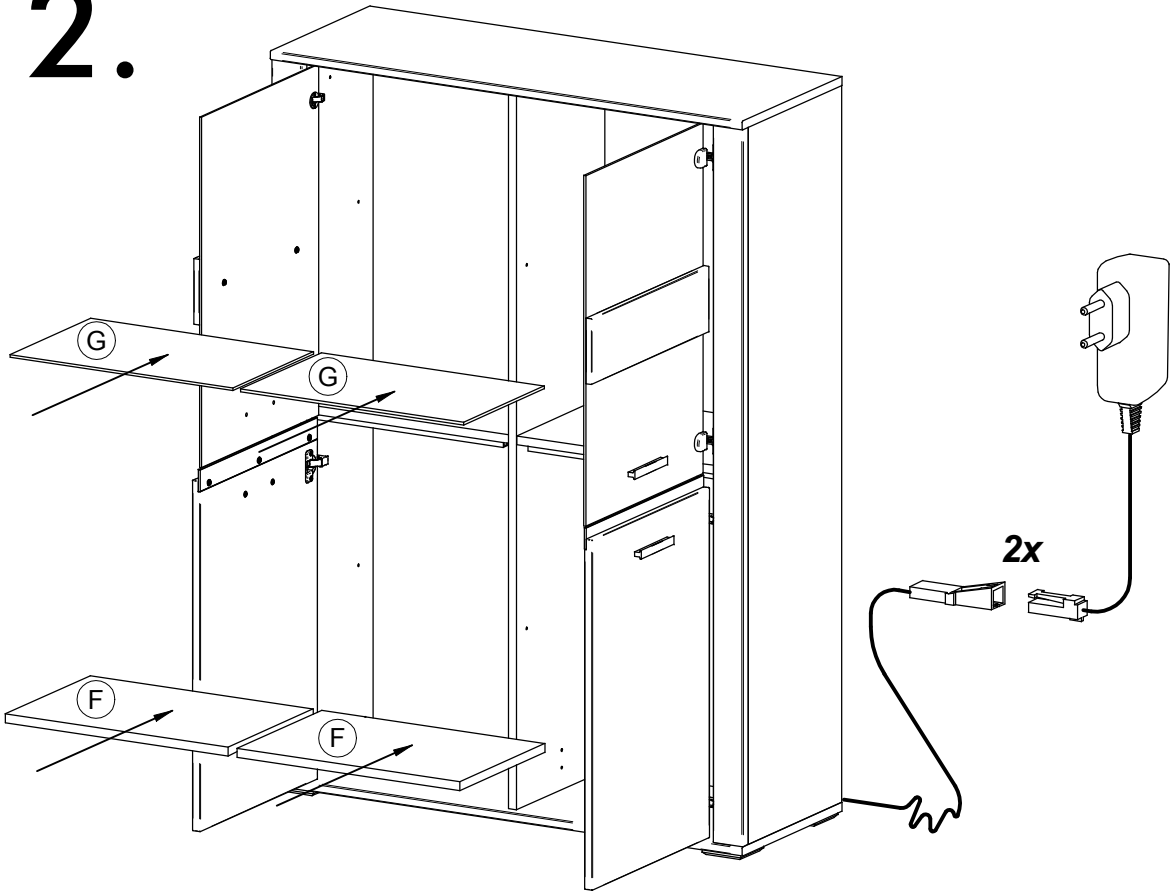

# 13.

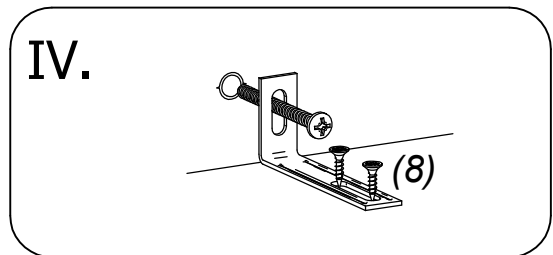
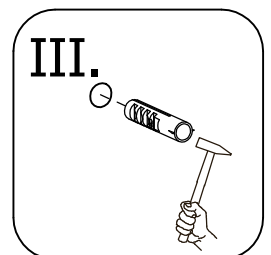
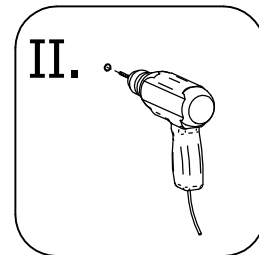
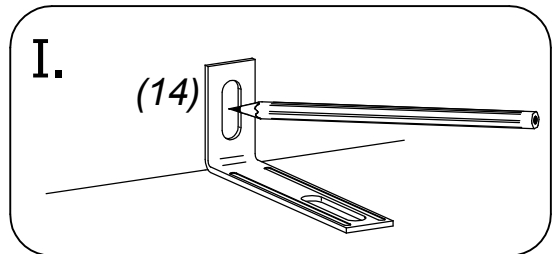
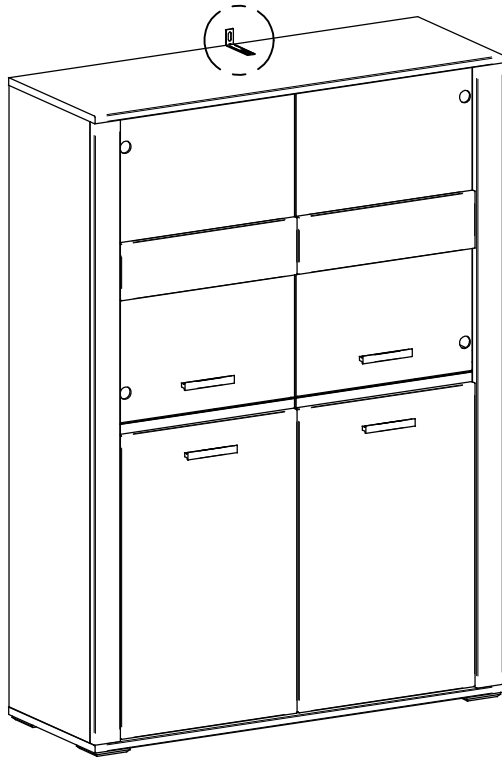
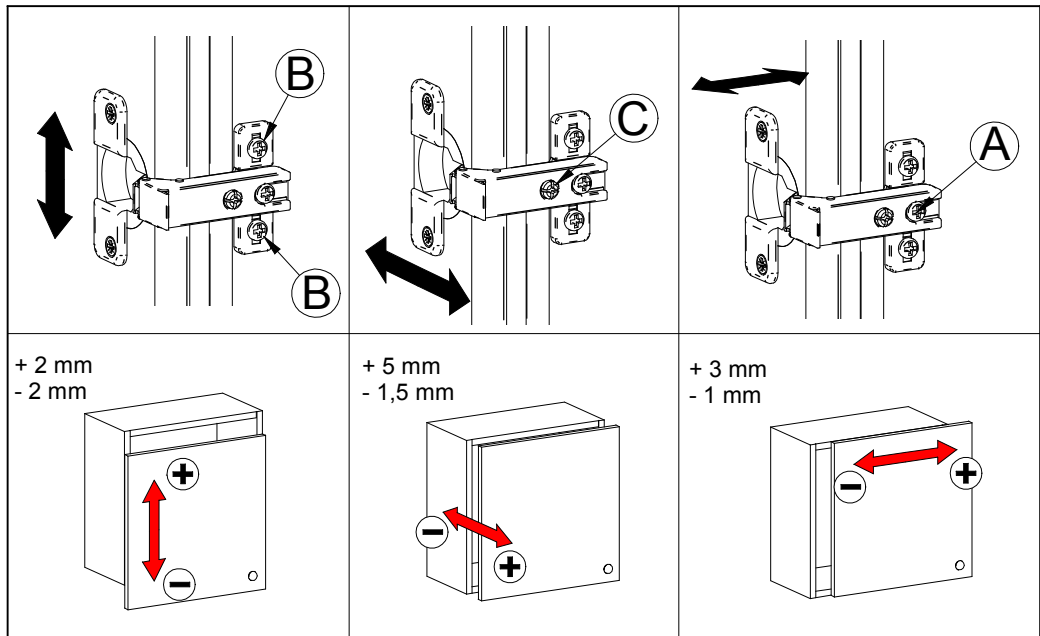





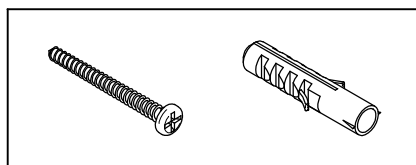



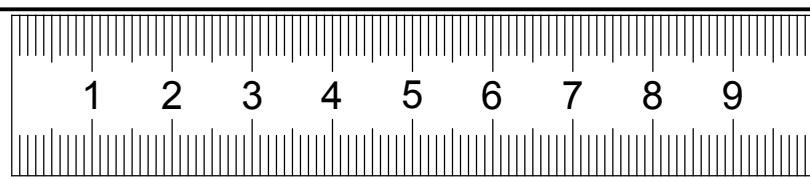
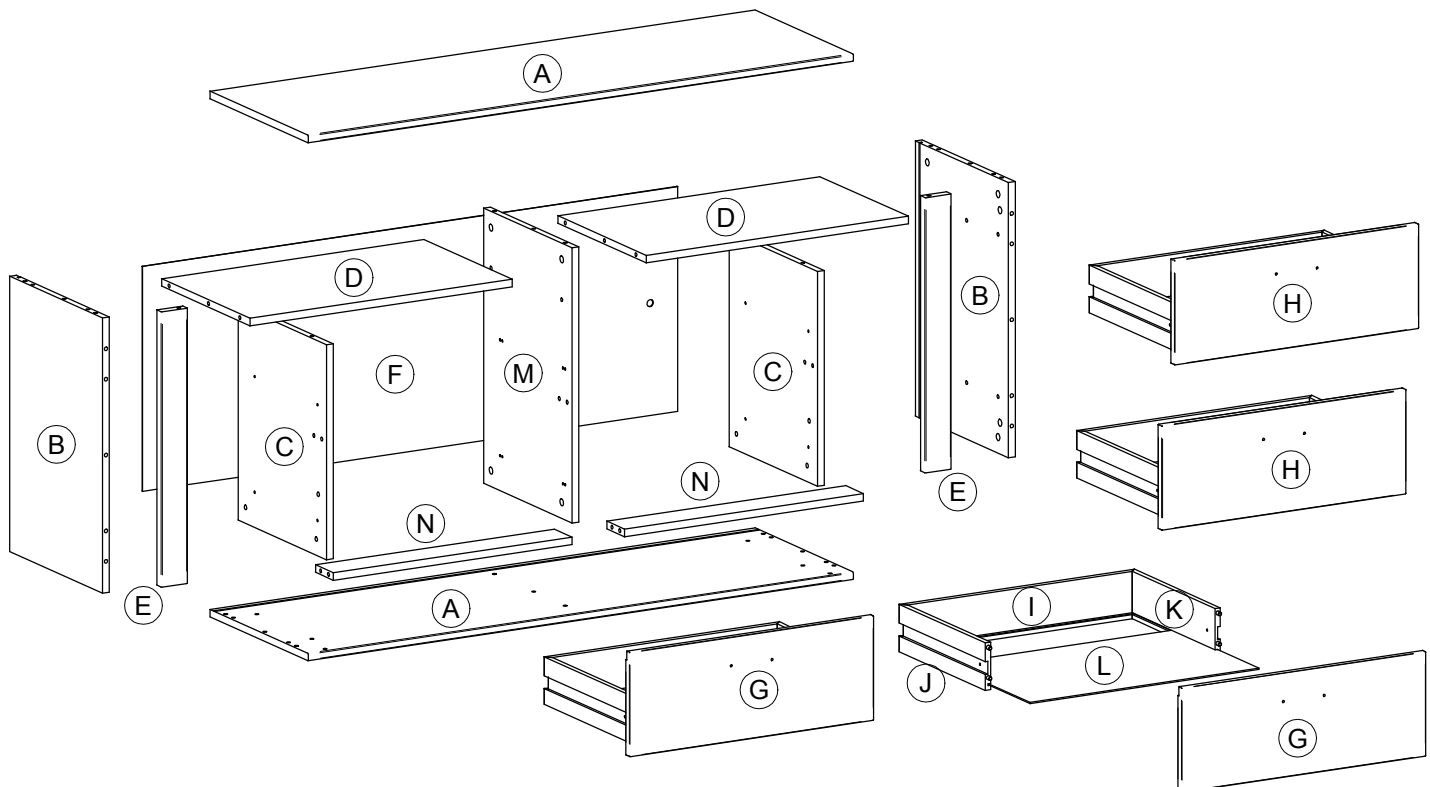
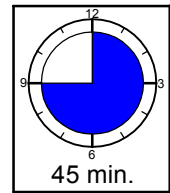
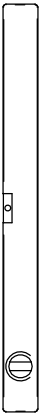
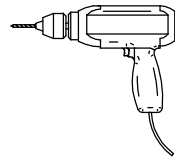
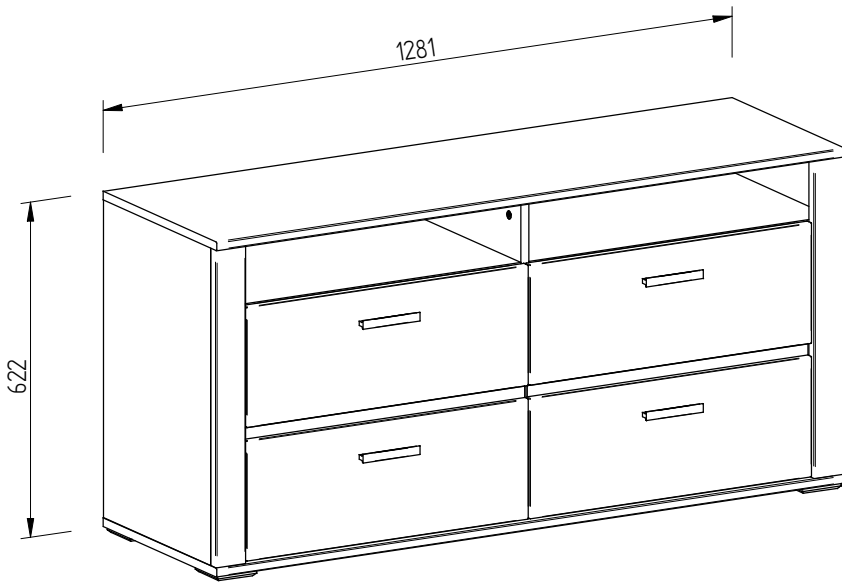
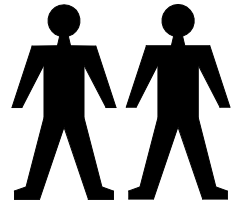

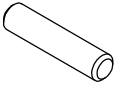

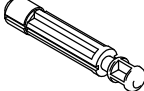
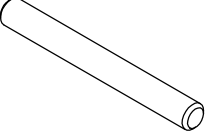

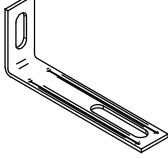
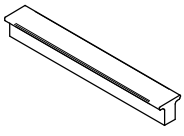

Wenn Möbelstücke umkippen, können ernste oder lebensgefährliche Verletzungen durch Einklemmen die Folge sein. Um zu verhindern, dass das Möbelstück umkippt, muss es fest an der Wand verankert werden. Beschläge für die Wandbefestigung sind nicht beige packt, da sie von der jeweiligen Wandbeschaffenheit abhängig sind. Befestigungsbeschläge benutzen, die für die heimischen Wände geeignet sind. Bei diesbezüglichen Fragen den örtlichen Fachhandel zu Rate ziehen.

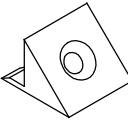
Prevrhnutie nábytku môže spôsobiť vážne či smrteľné zranenia. Aby sa zabránilo prevrhnutiu nábytku, upevnite ho ku stene. Upevňovací materiál nie je súčasťou balenia, pretože na každý materiál steny je potrebné použiť iný typ skrutky a hmoždinky. Použite taký upevňovací materiál, ktorý je vhodný na konkrétny typ steny u vás doma. V prípade potreby sa poraďte s odborníkom.

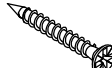

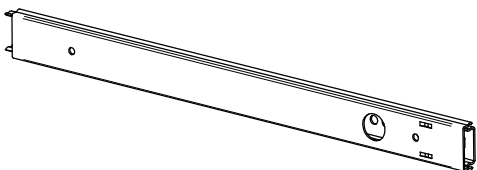
# BENO 33

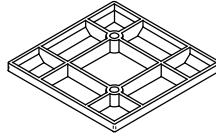
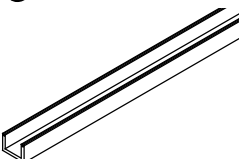
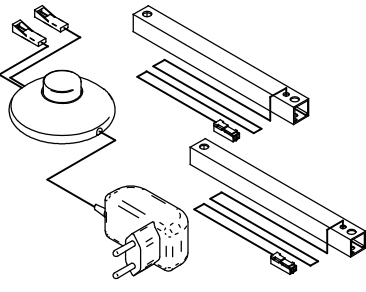
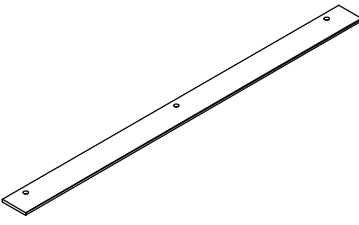
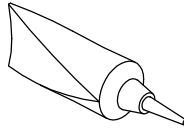

<b>1</b> $\varnothing 8 \times 35$ x44 	<b>2</b> $\varnothing 15$ x16 	<b>3</b> $\varnothing 8$ x16 	<b>4</b> $\varnothing 8 \times 70$ x5 	<b>5</b> M4x20 x8 
<b>6</b> $\varnothing 4 \times 20$ x10 	<b>7</b> $\varnothing 6,5$ x6 	<b>8</b> $\varnothing 3,5 \times 15$ x2 	<b>9</b> x1 	<b>10</b> x4 
<b>11</b> $\varnothing 6,3 \times 11$ x12 	<b>12</b> x16 	<b>13</b> $\varnothing 3,5 \times 20$ x24 	<b>14</b> $\varnothing 3 \times 25$ x4 	<b>15</b> $\varnothing M4 \times 10$ x8 
<b>16</b> x8 	<b>17</b> x2 	<b>18</b> x5 	<b>19</b> x2 	
<b>20</b> x1 	<b>21</b> x2 	<b>22</b> x2 LEIM/LEPIDLO 	<b>23</b> x8 	
<b>24</b> $\varnothing 4 \times 15$ x8 				

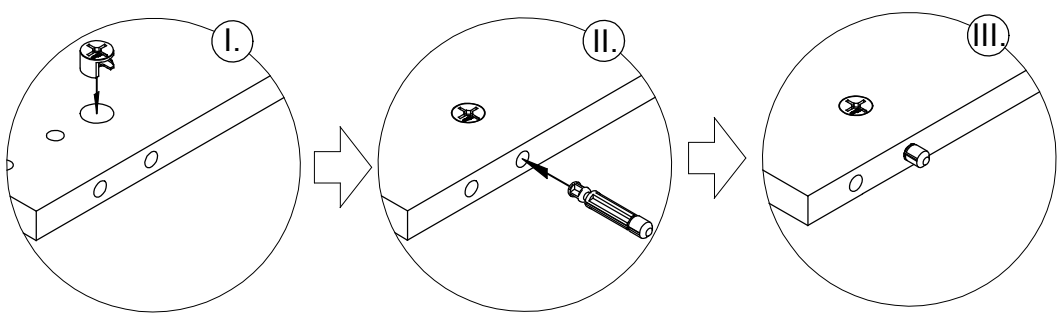
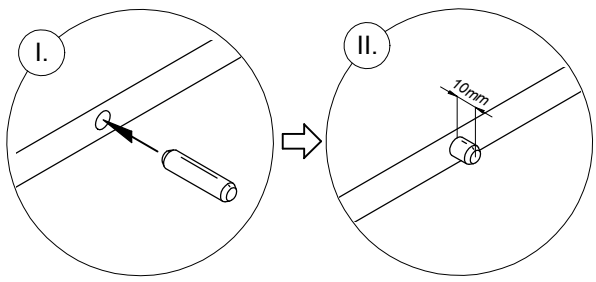

# 1.

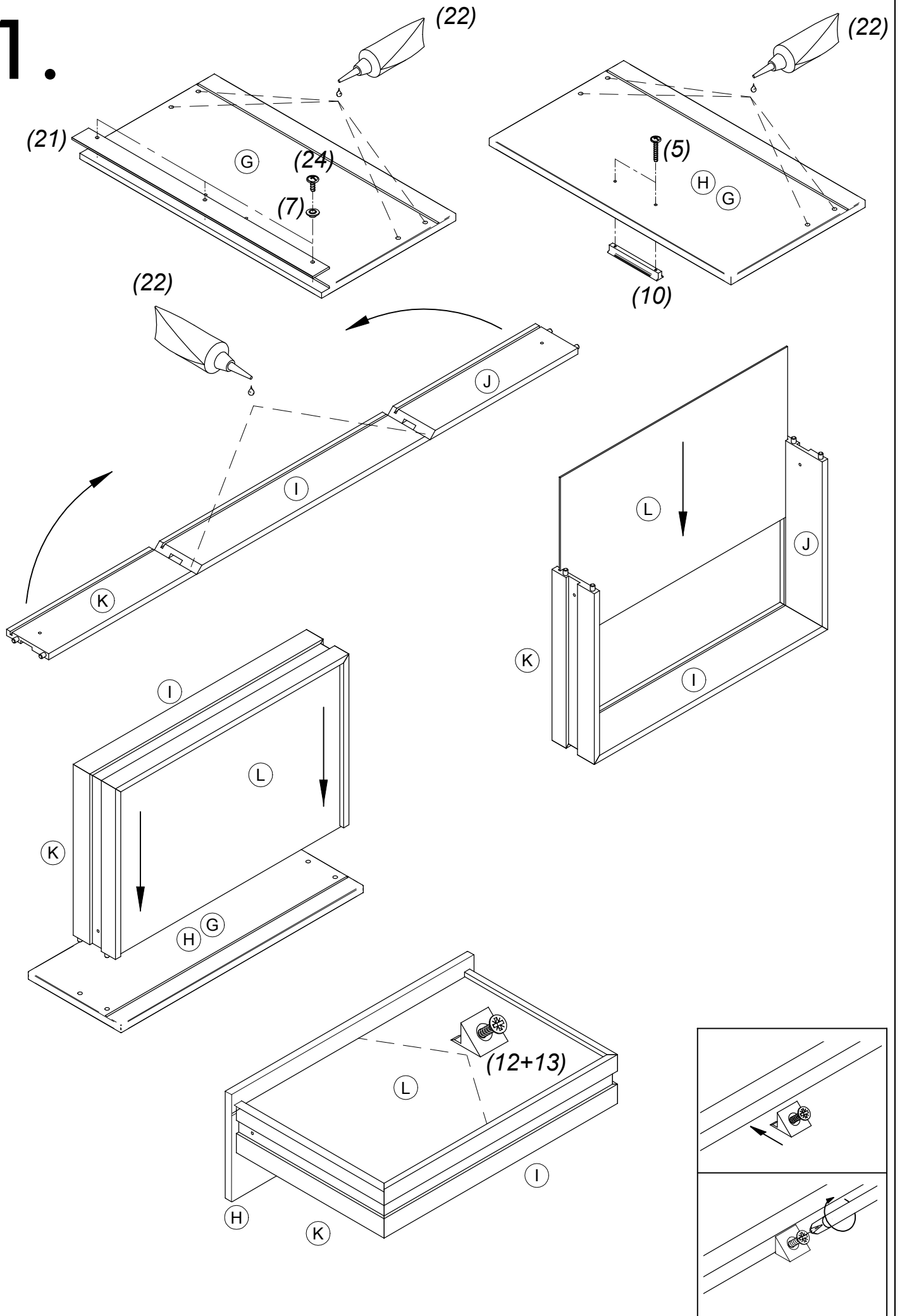

# 2.

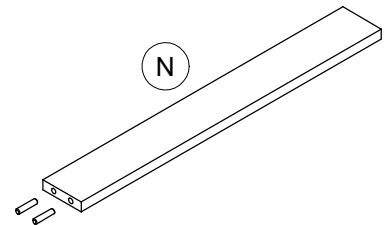
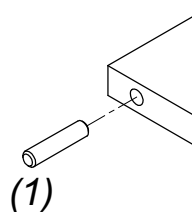
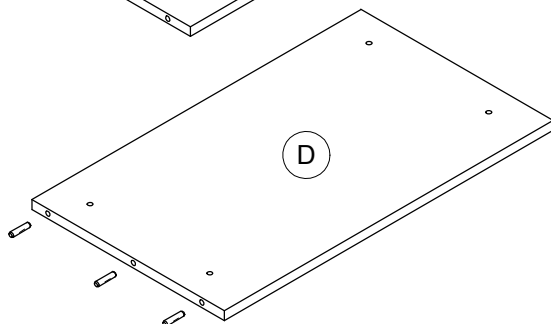
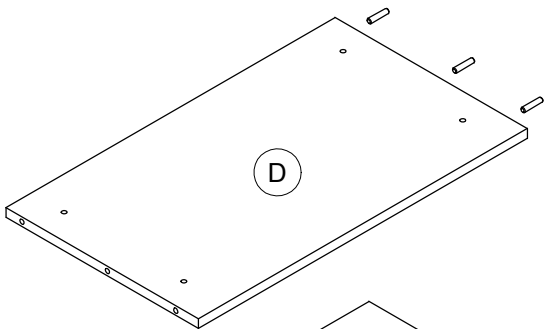
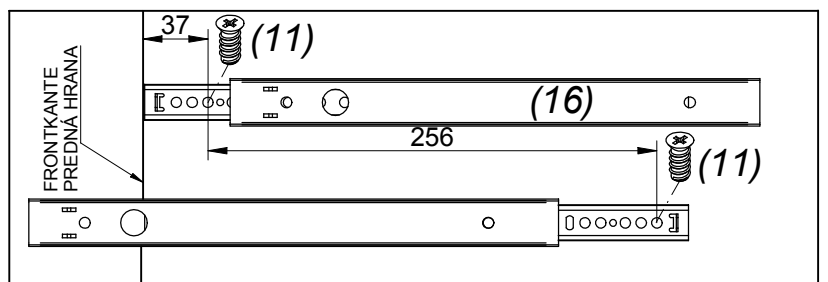
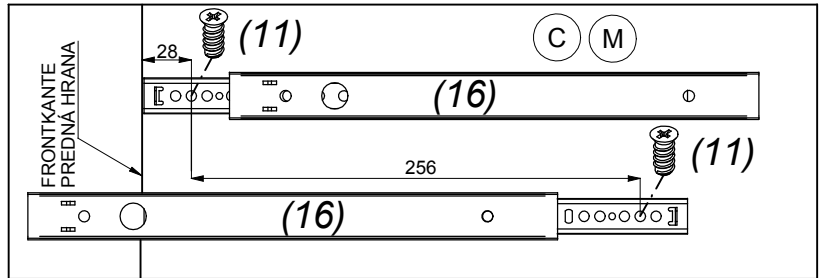
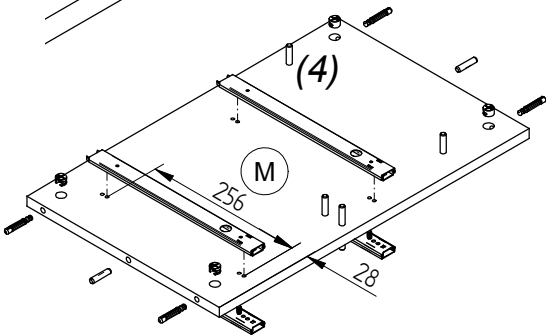
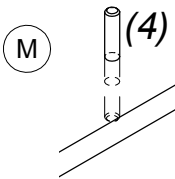
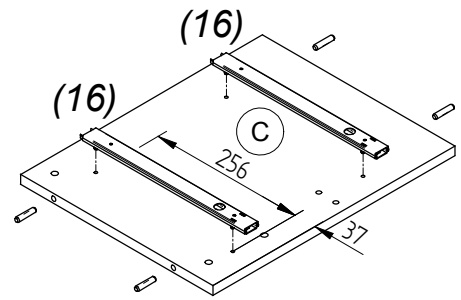
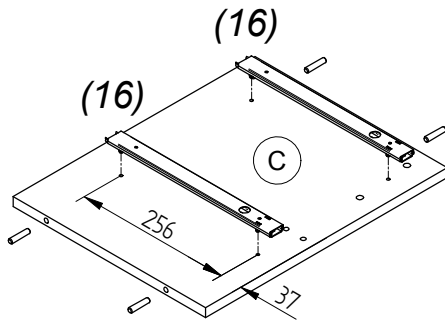
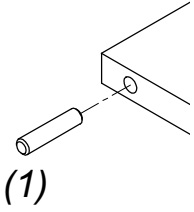
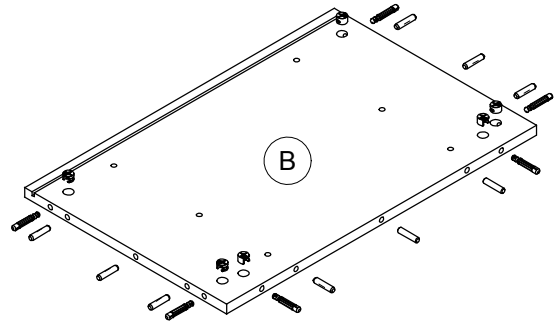
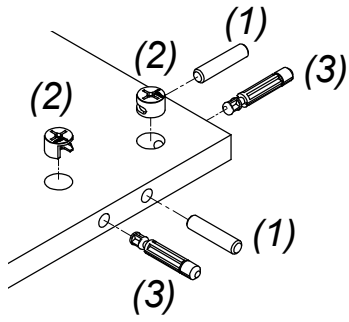

# 3.

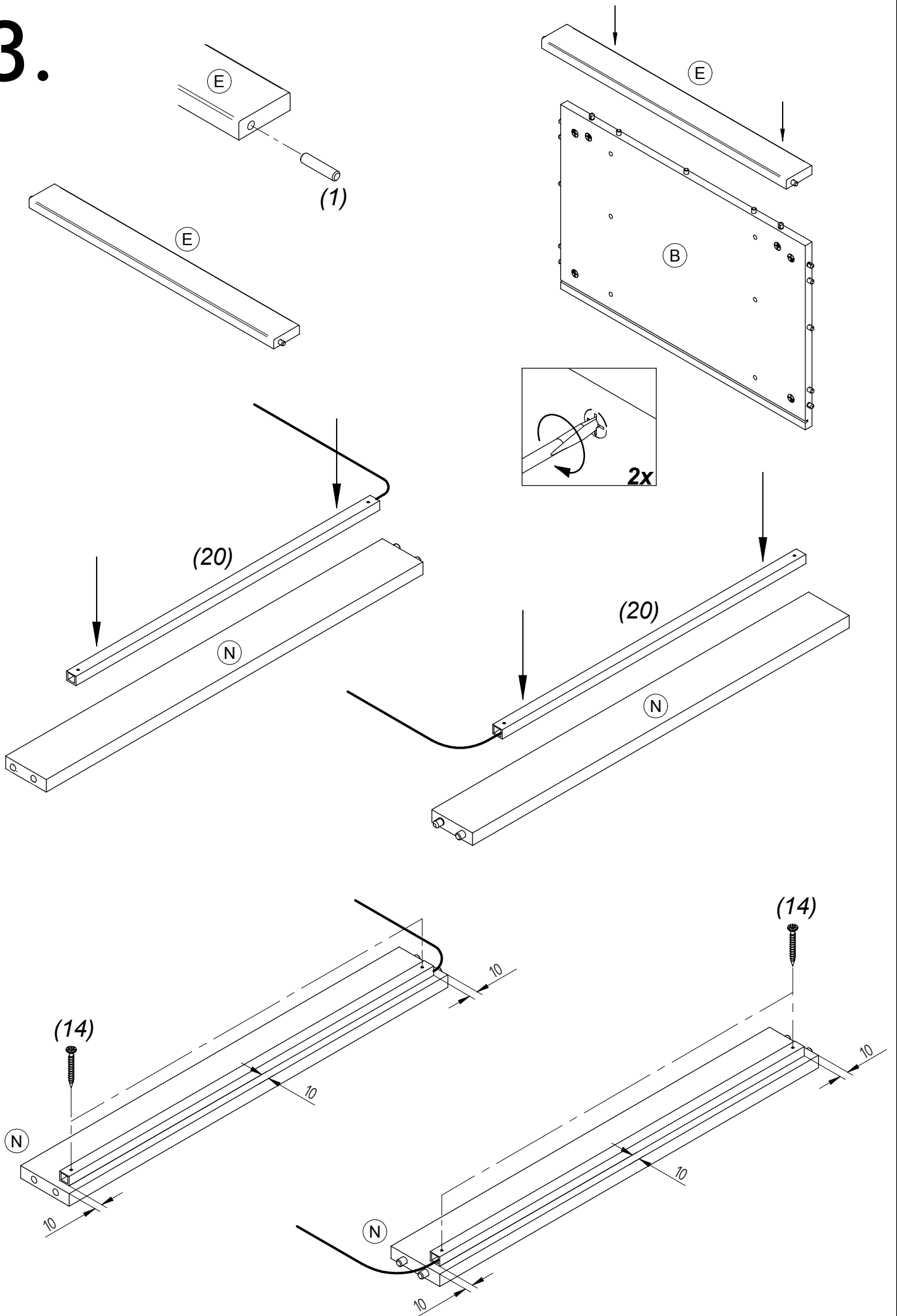

# 4.

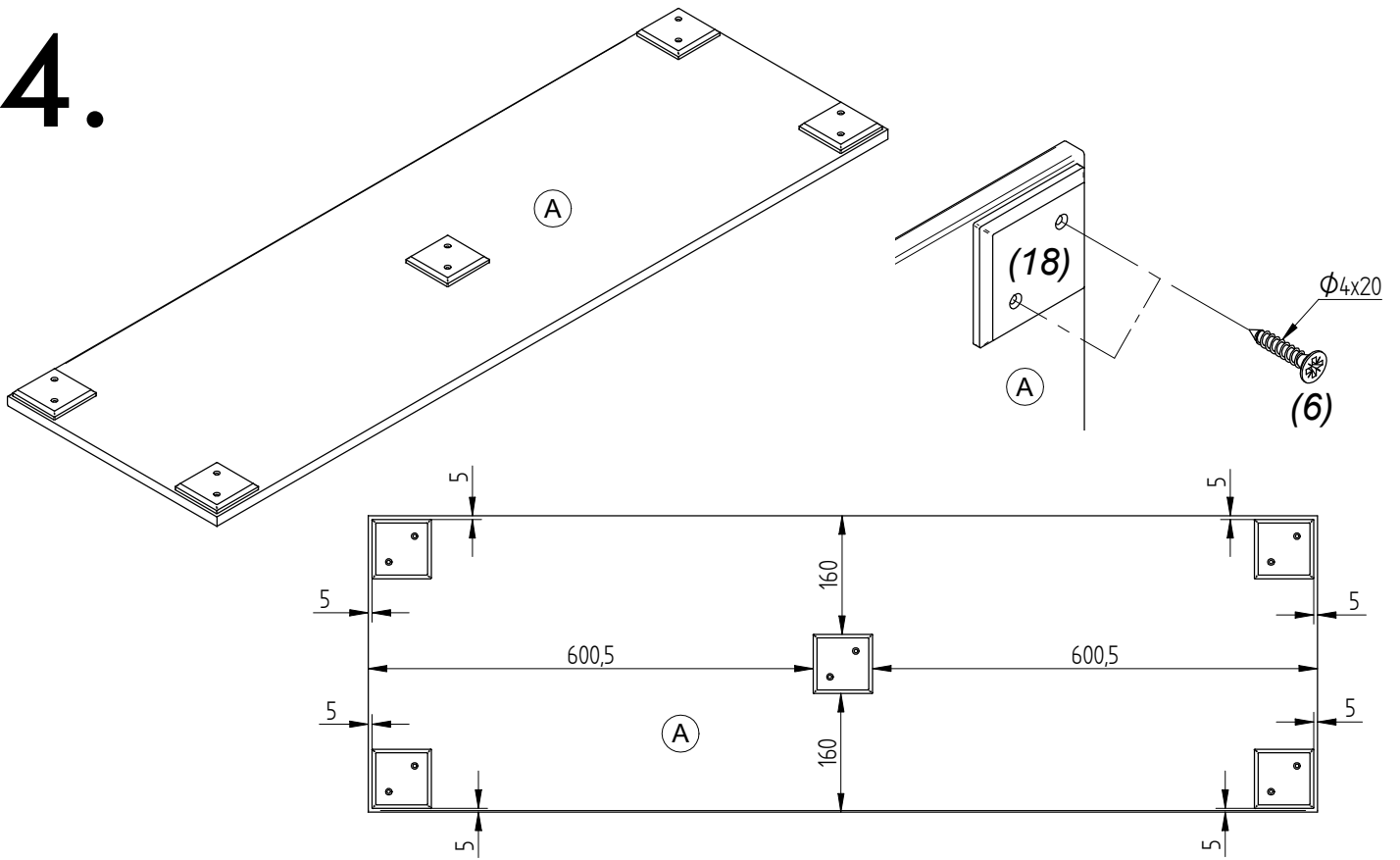

# 5.

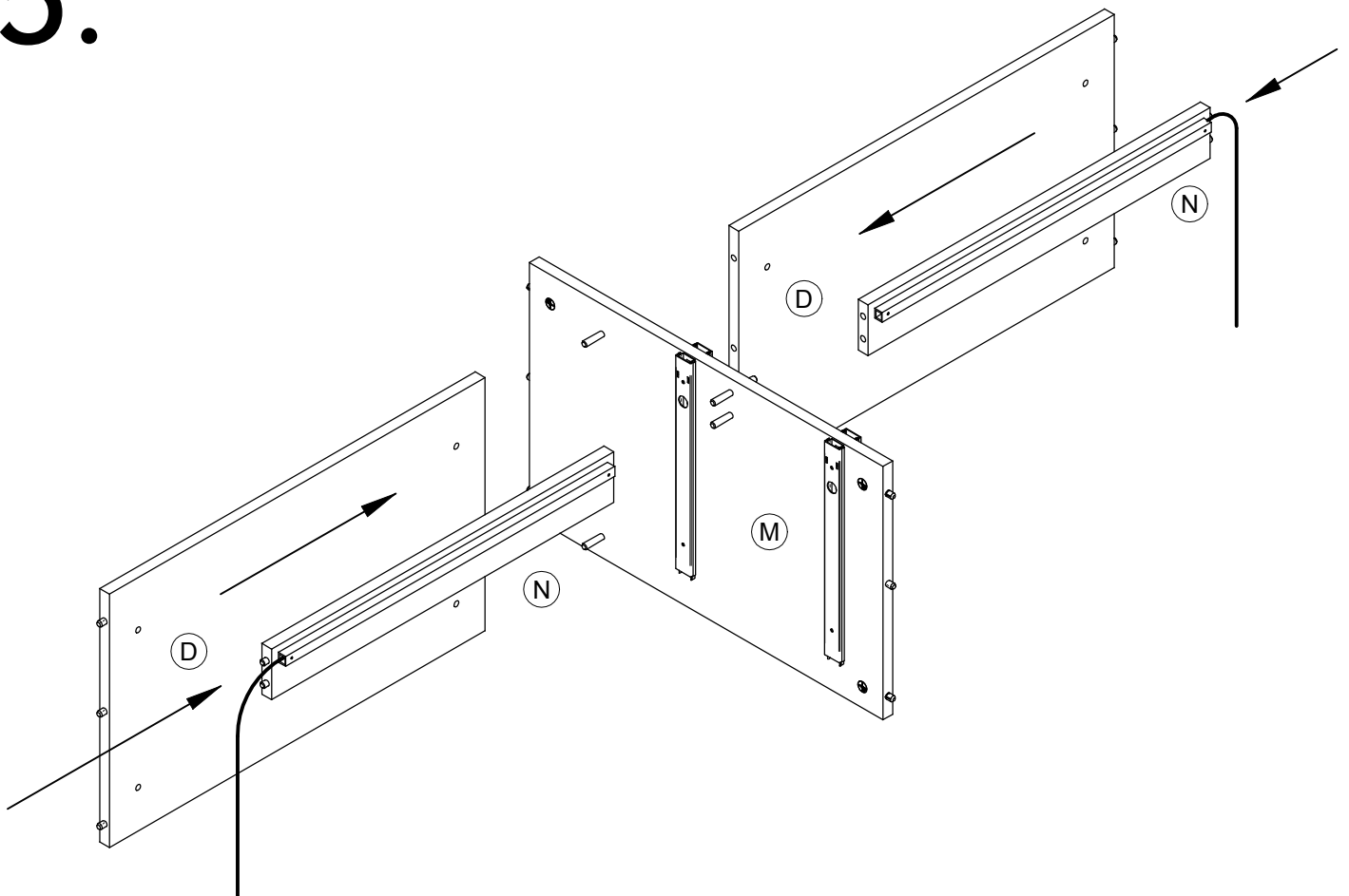



6.

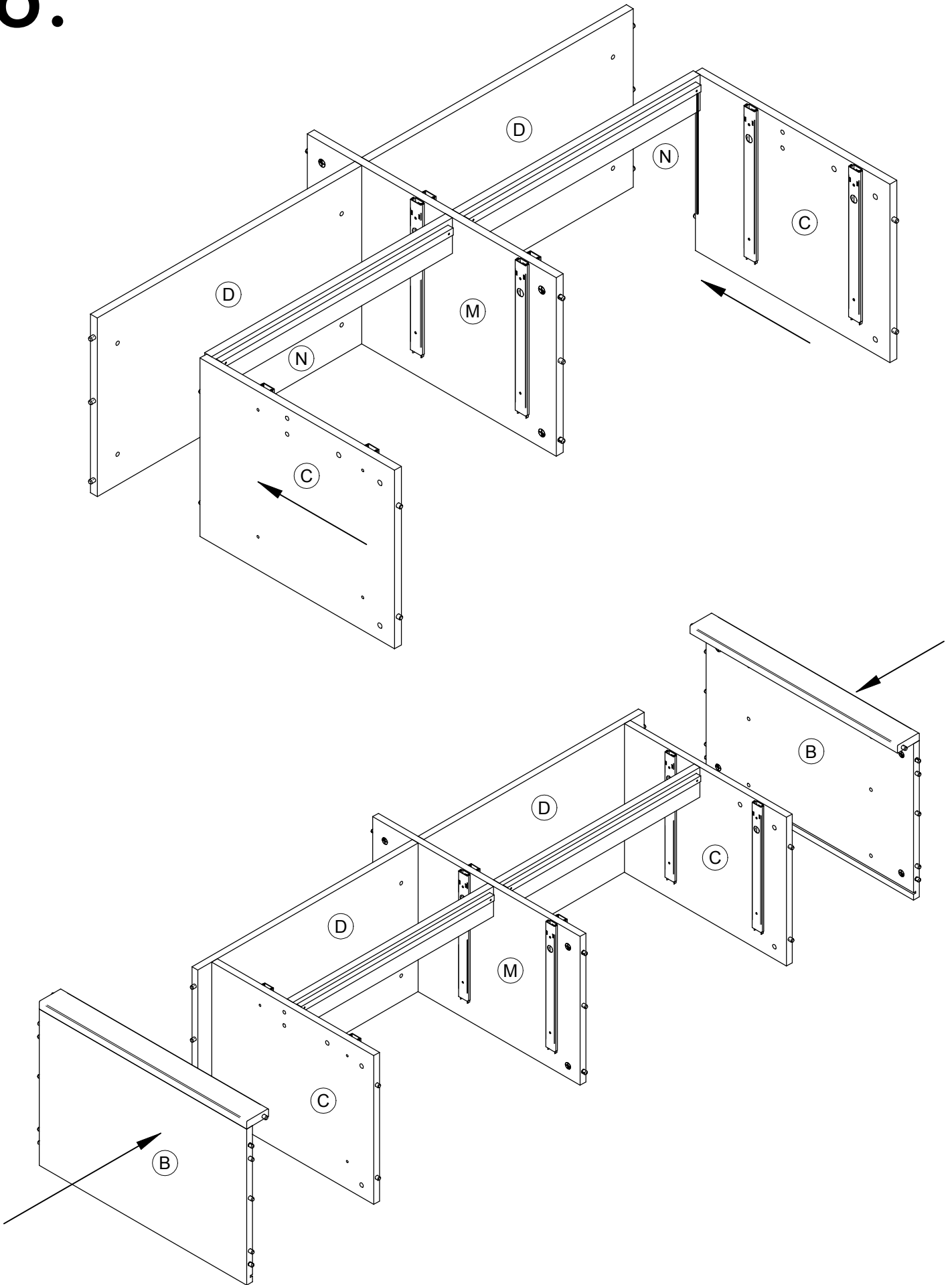

# 7.

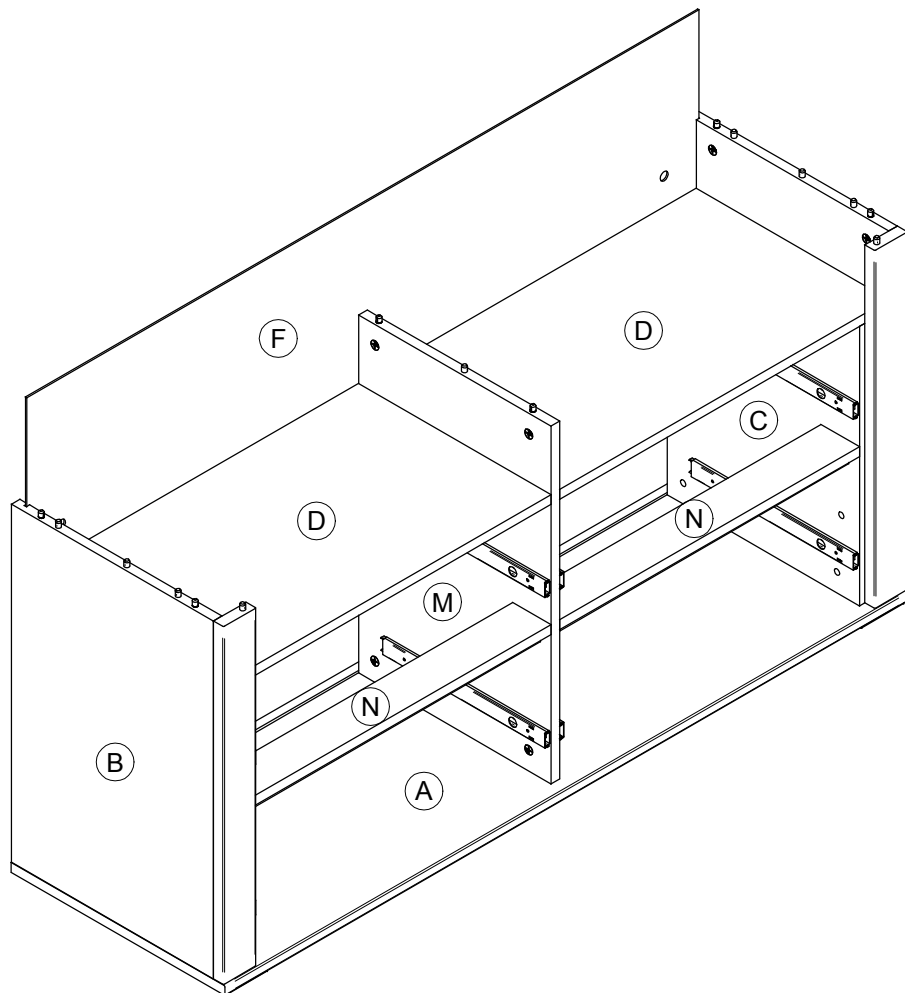
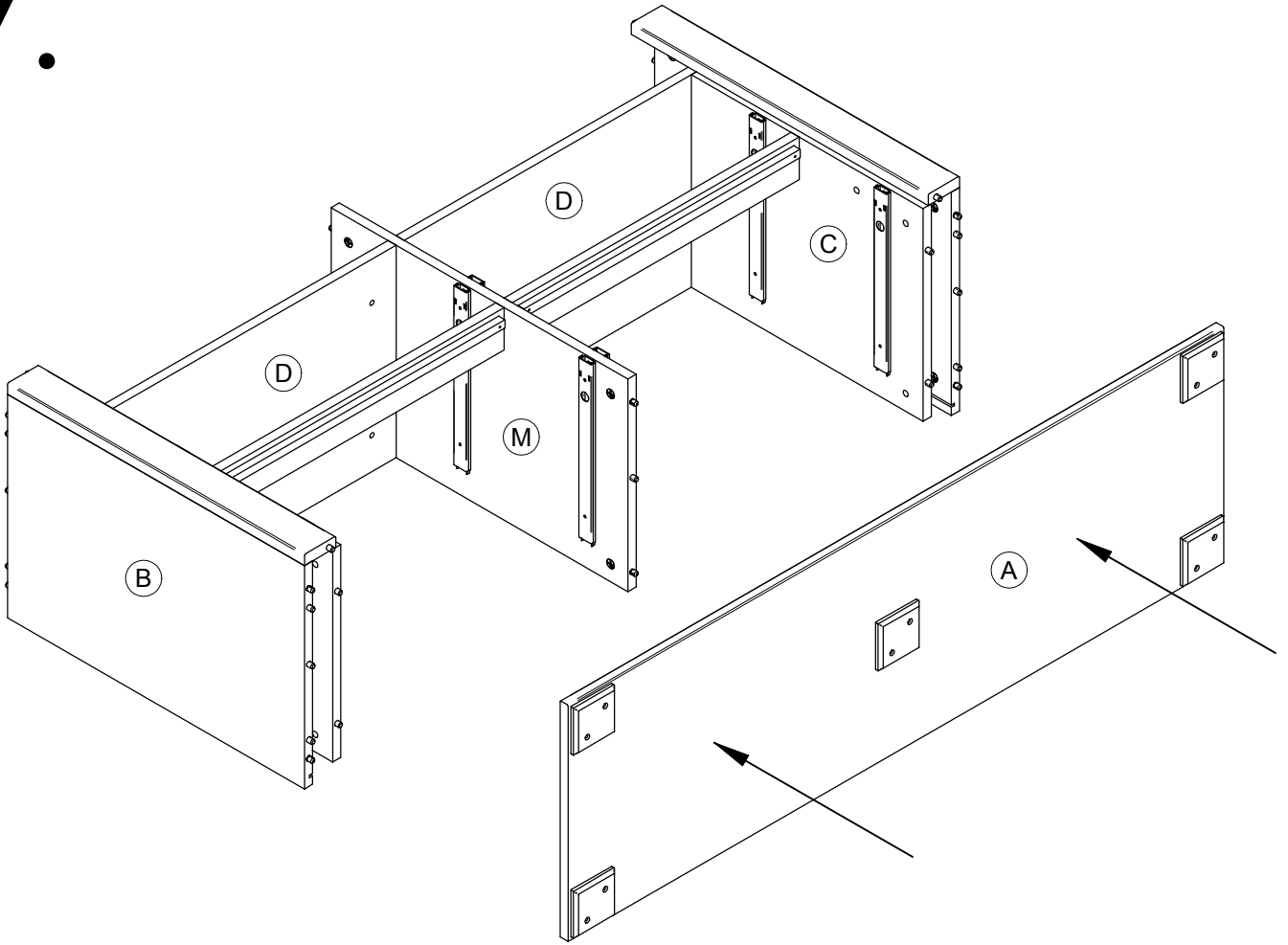

# 8.

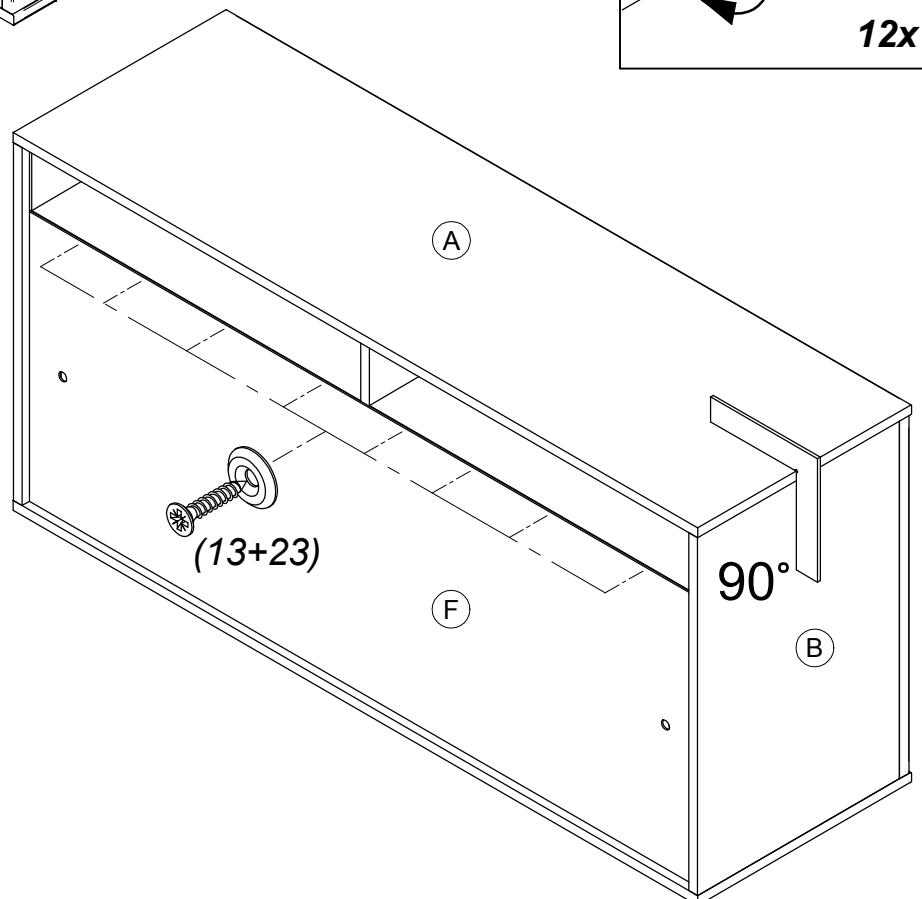
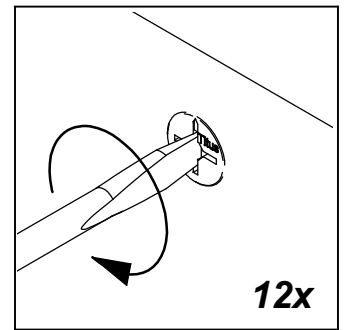
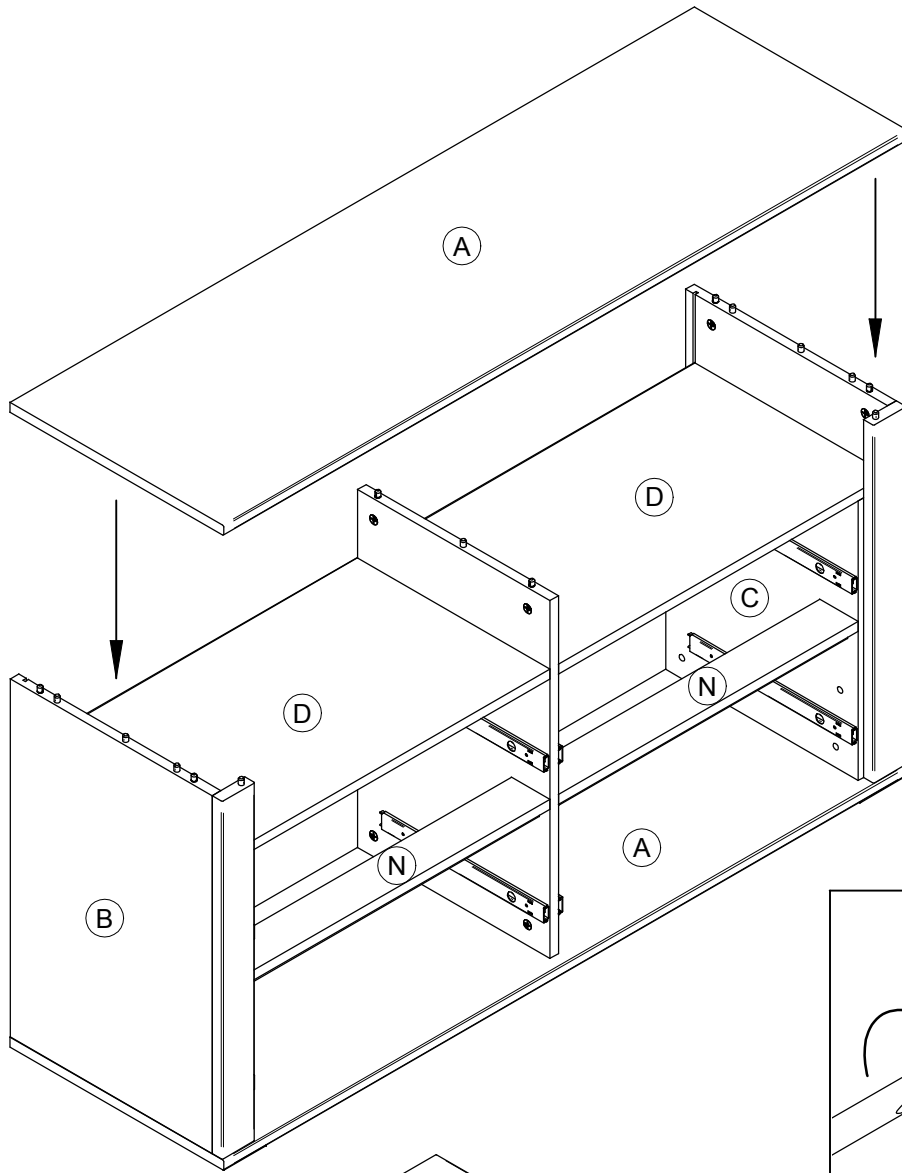

# 9.

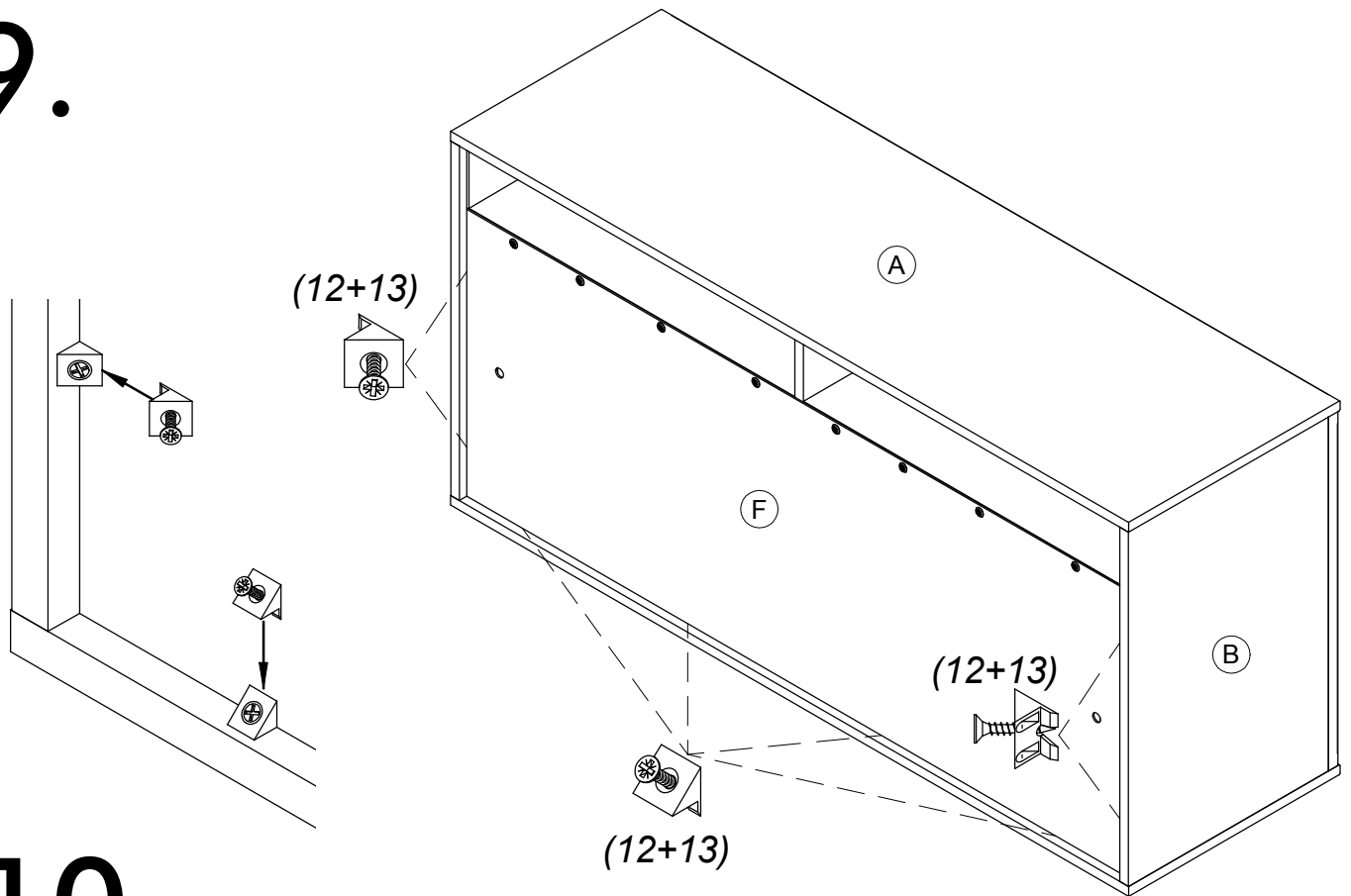

# 10.

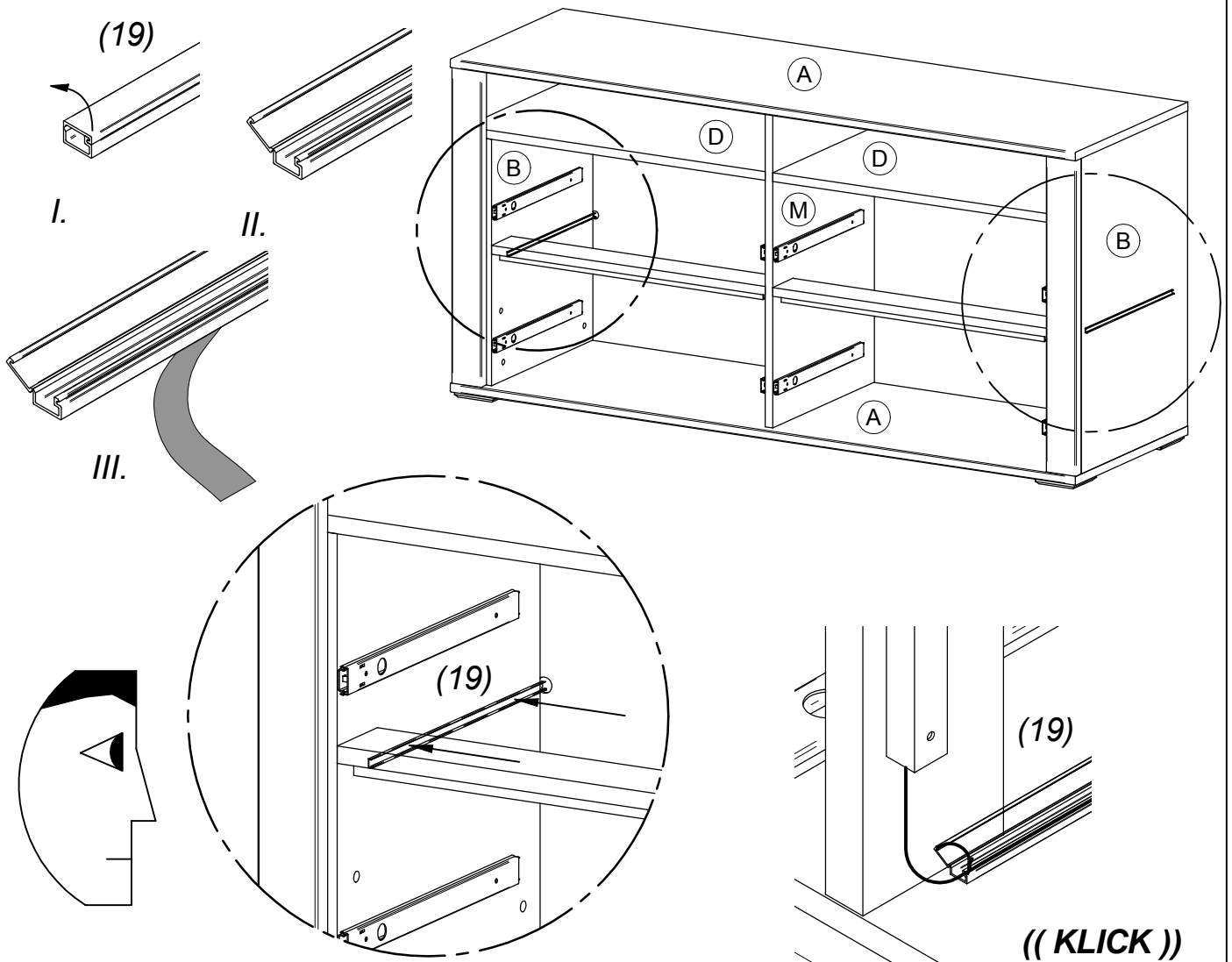

# 11.

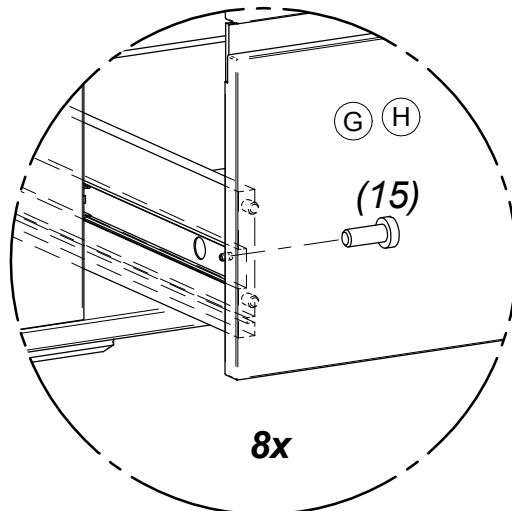
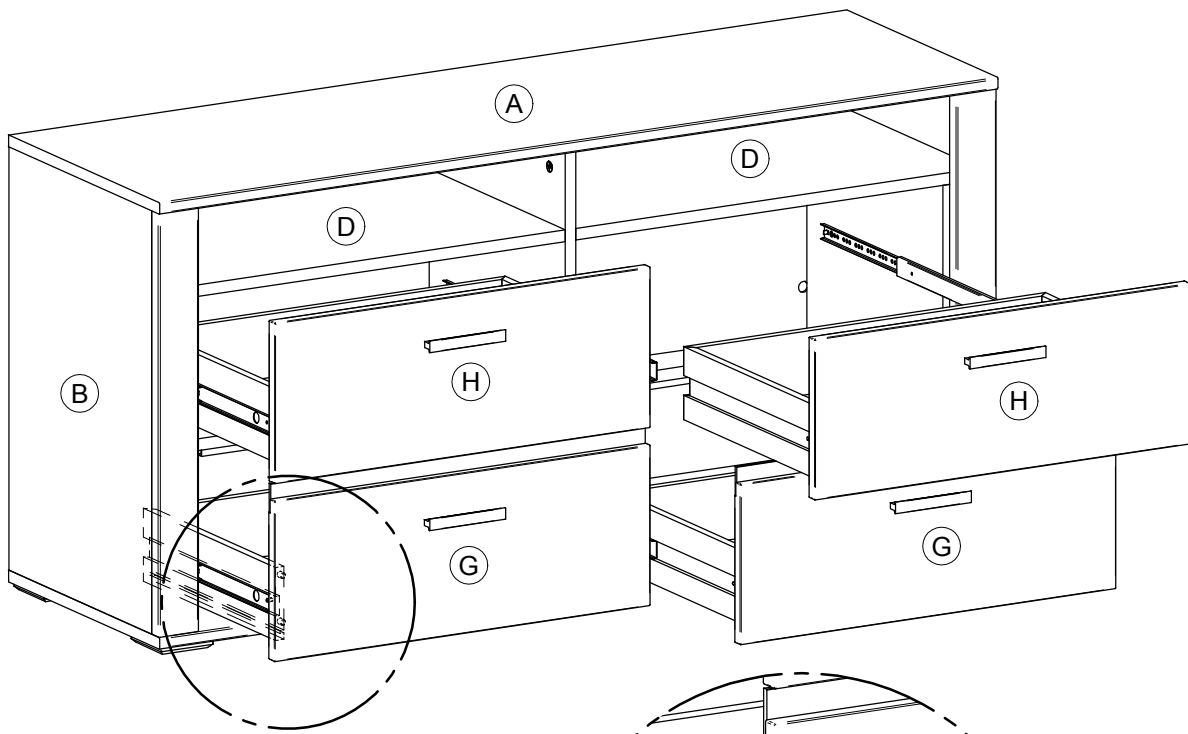
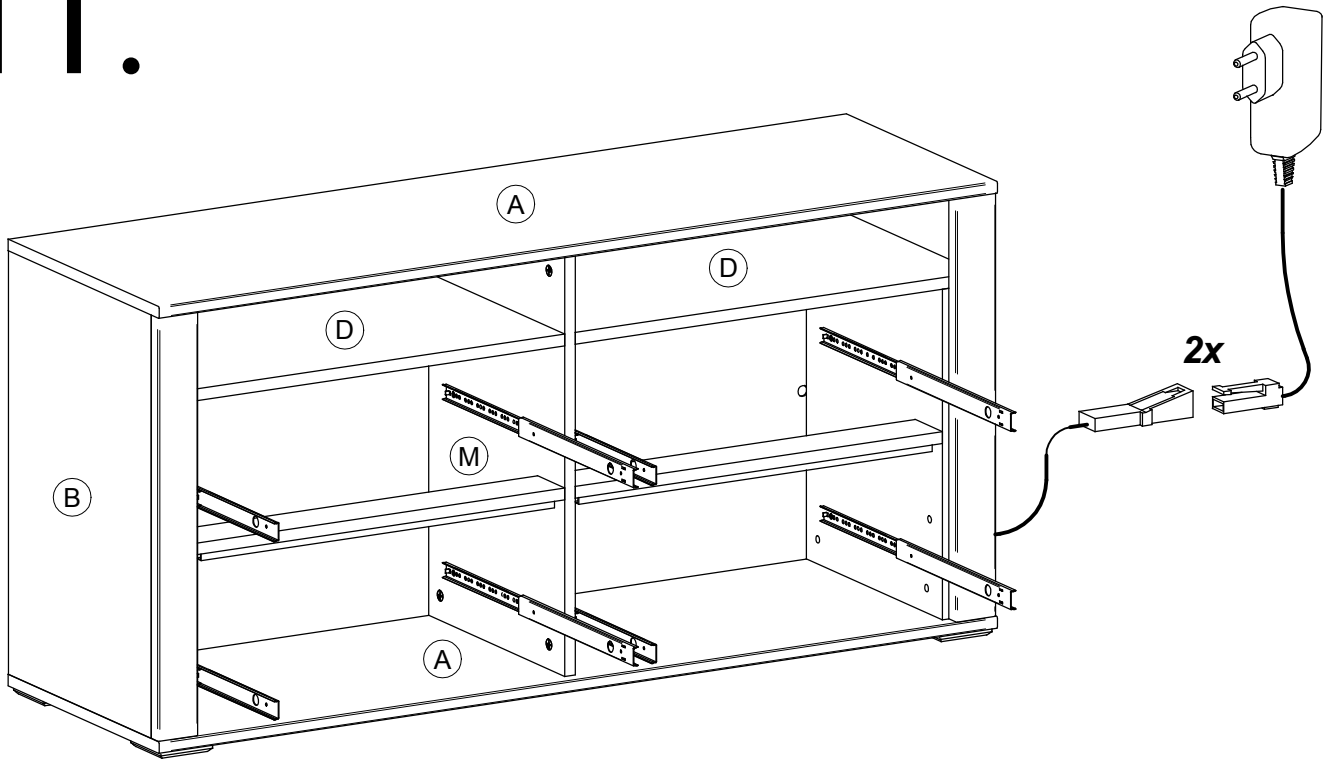

# 12.

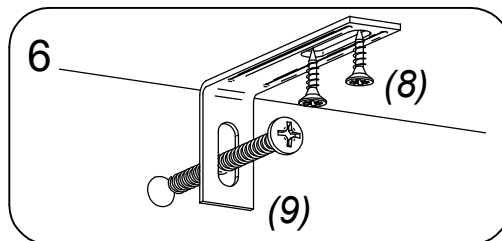
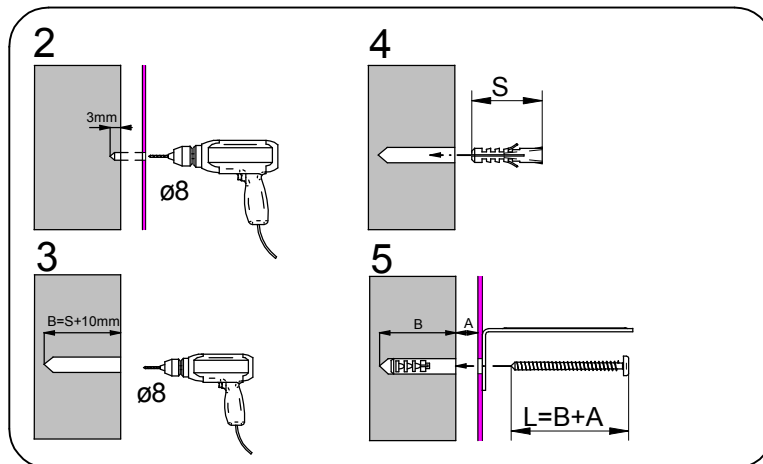
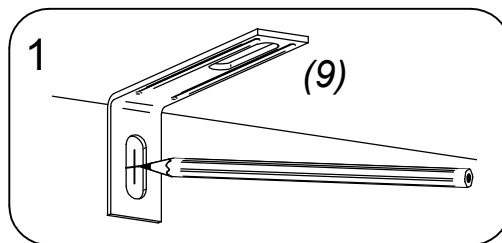
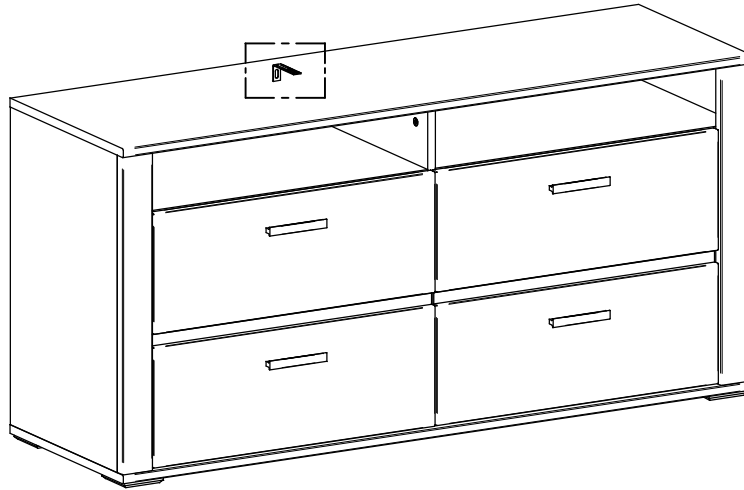

Wenn Möbelstücke umkippen, können ernste oder lebensgefährliche Verletzungen durch Einklemmen die Folge sein. Um zu verhindern, dass das Möbelstück umkippt, muss es fest an der Wand verankert werden. Beschläge für die Wandbefestigung sind nicht beige packt, da sie von der jeweiligen Wandbeschaffenheit abhängig sind. Befestigungsbeschläge benutzen, die für die heimischen Wände geeignet sind. Bei diesbezüglichen Fragen den örtlichen Fachhandel zu Rate ziehen.

Prevrhnutie nábytku môže spôsobiť vážne či smrteľné zranenia. Aby sa zabránilo prevrhnutiu nábytku, upevnite ho ku stene. Upevňovací materiál nie je súčasťou balenia, pretože na každý materiál steny je potrebné použiť iný typ skrutky a hmoždinky. Použite taký upevňovací materiál, ktorý je vhodný na konkrétny typ steny u vás doma. V prípade potreby sa poraďte s odborníkom.

