

A	B	C (mm)		D
1	S220-1020	348	250	1/2
2	S220-1021	348	250	1/2
3	S220-1022	348	220	1/2
4	S220-2015	1171	250	1/2
5	S220-2016	1171	250	1/2
6	S220-5506	1009	179	1/2
7	S220-7019	100	880	2/2
8	S220-7020	400	1200	2/2
9	S220-9307	1148	359	1/2

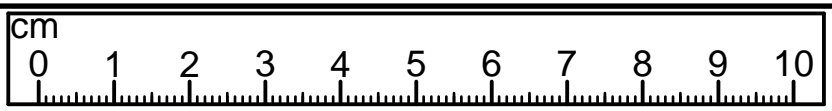

2x a43	2x b35	12x Ø8x30 mm f1	2x Ø10x50 mm f35	4x l1	12x l2	2x m25I2	2x 120 N m27I1	2x m25I9	1x n165IP	1x n165L	3x silikon o21	11x Ø5.3/Ø8.3x4.8 mm o54
4x Ø4x30 mm p21	2x Ø6x60 mm p127	11x Ø3.5x16 mm p38	12x Ø3.5x15 mm p51	12x Ø15x12 mm #16 r1	12x r42	12x Ø16 s2						

1 

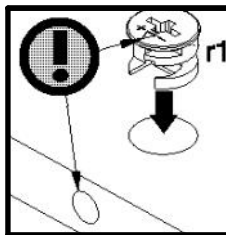
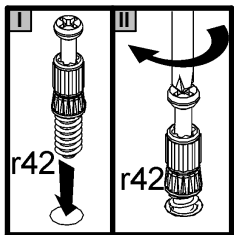
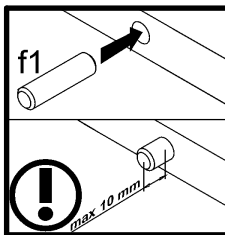
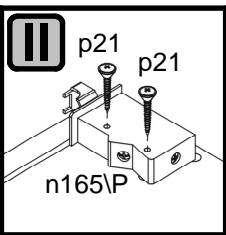
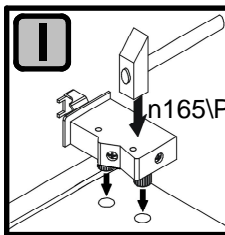
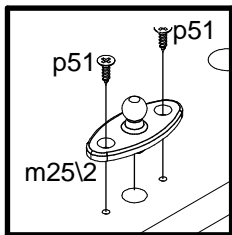
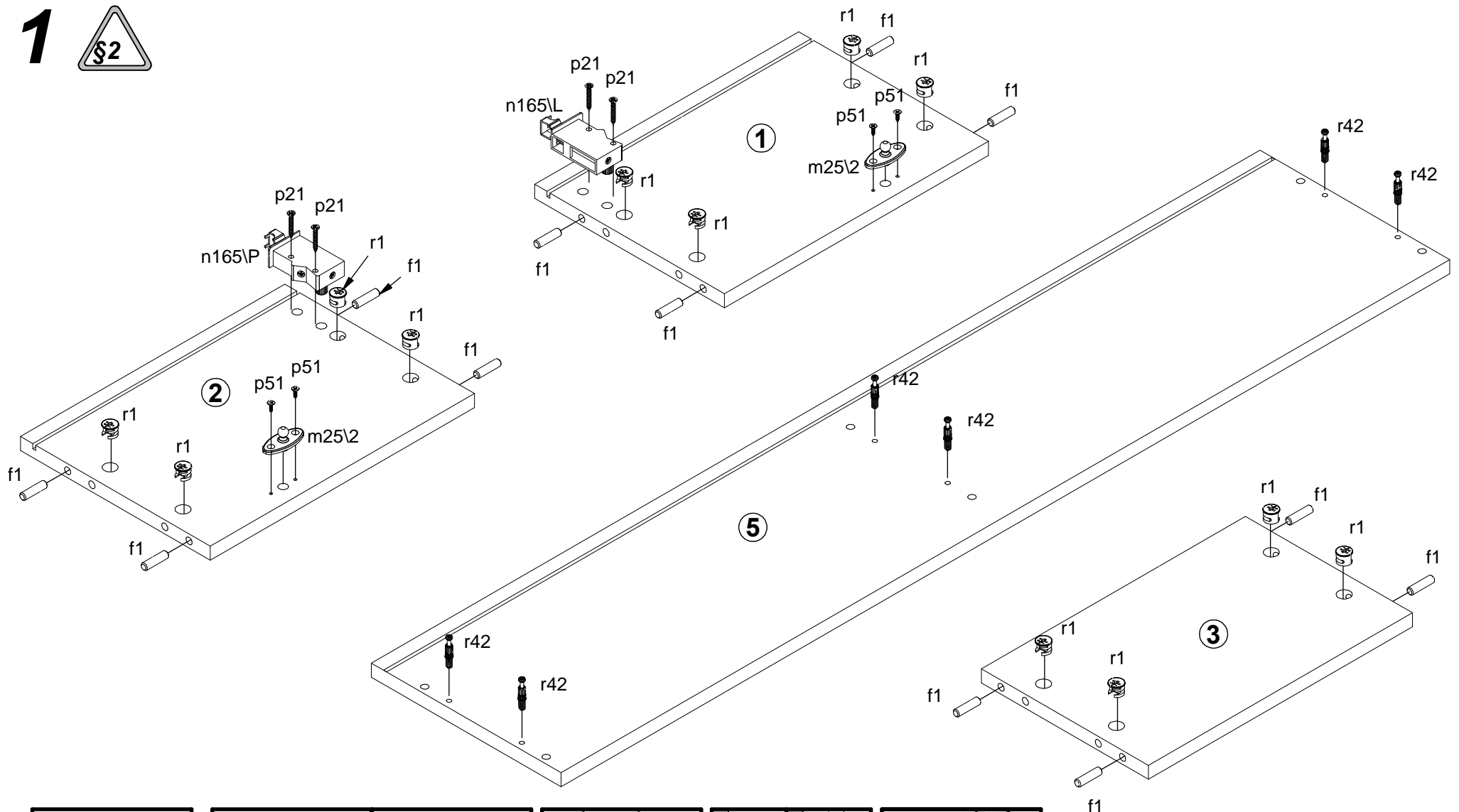

1

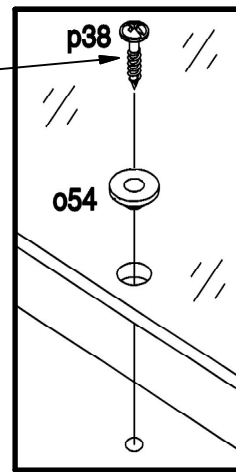
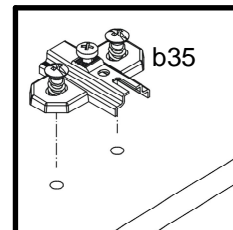
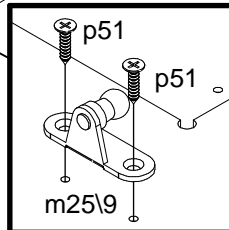
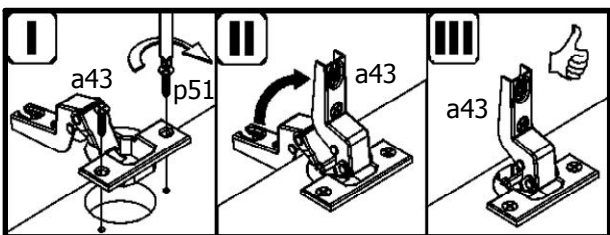
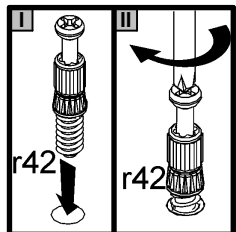
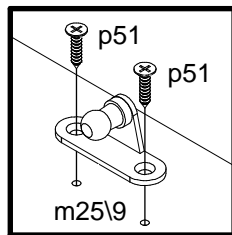
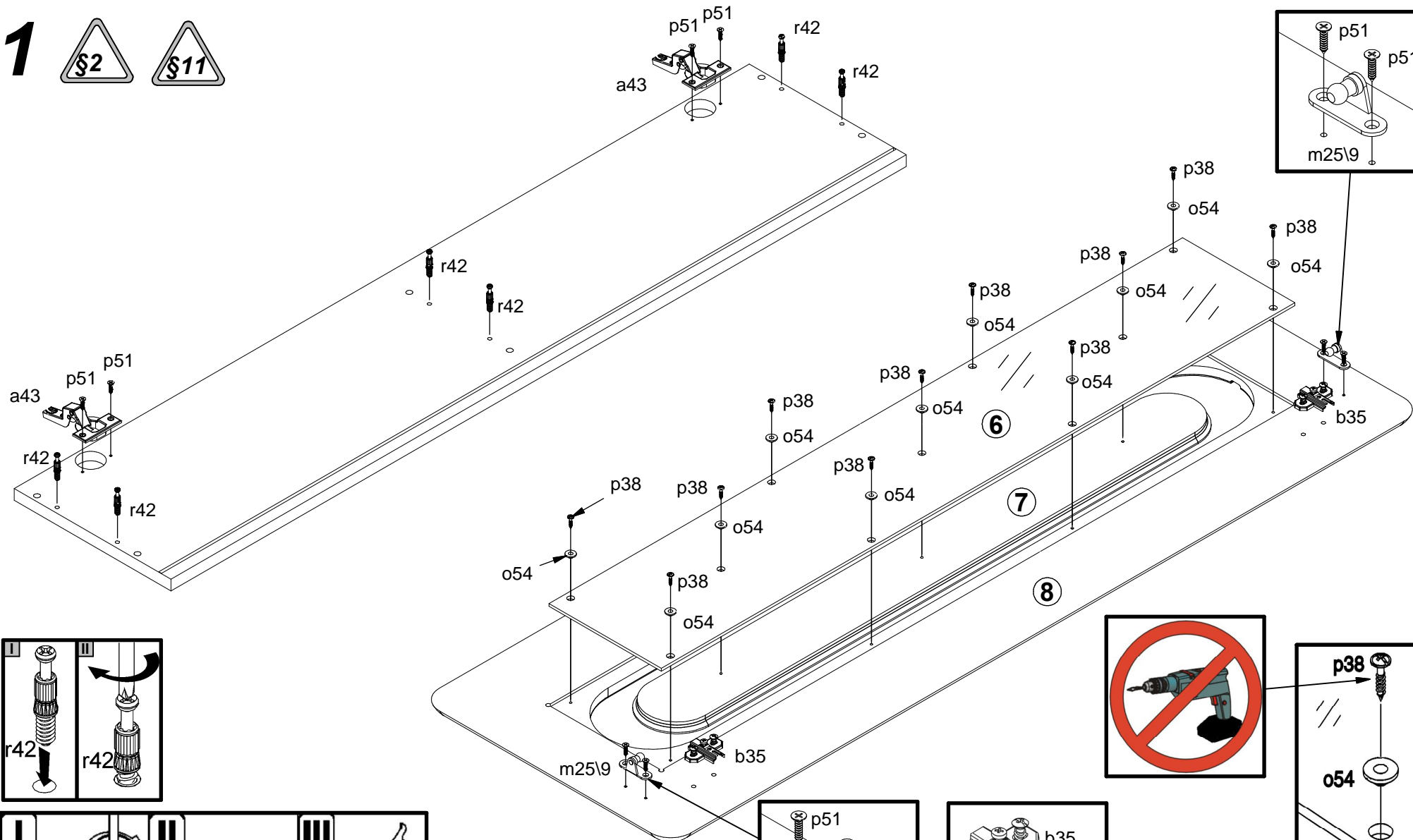

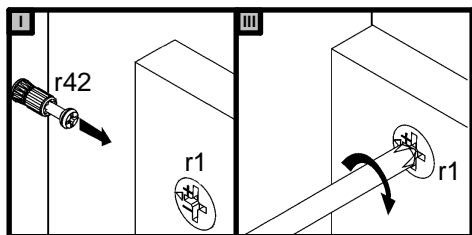
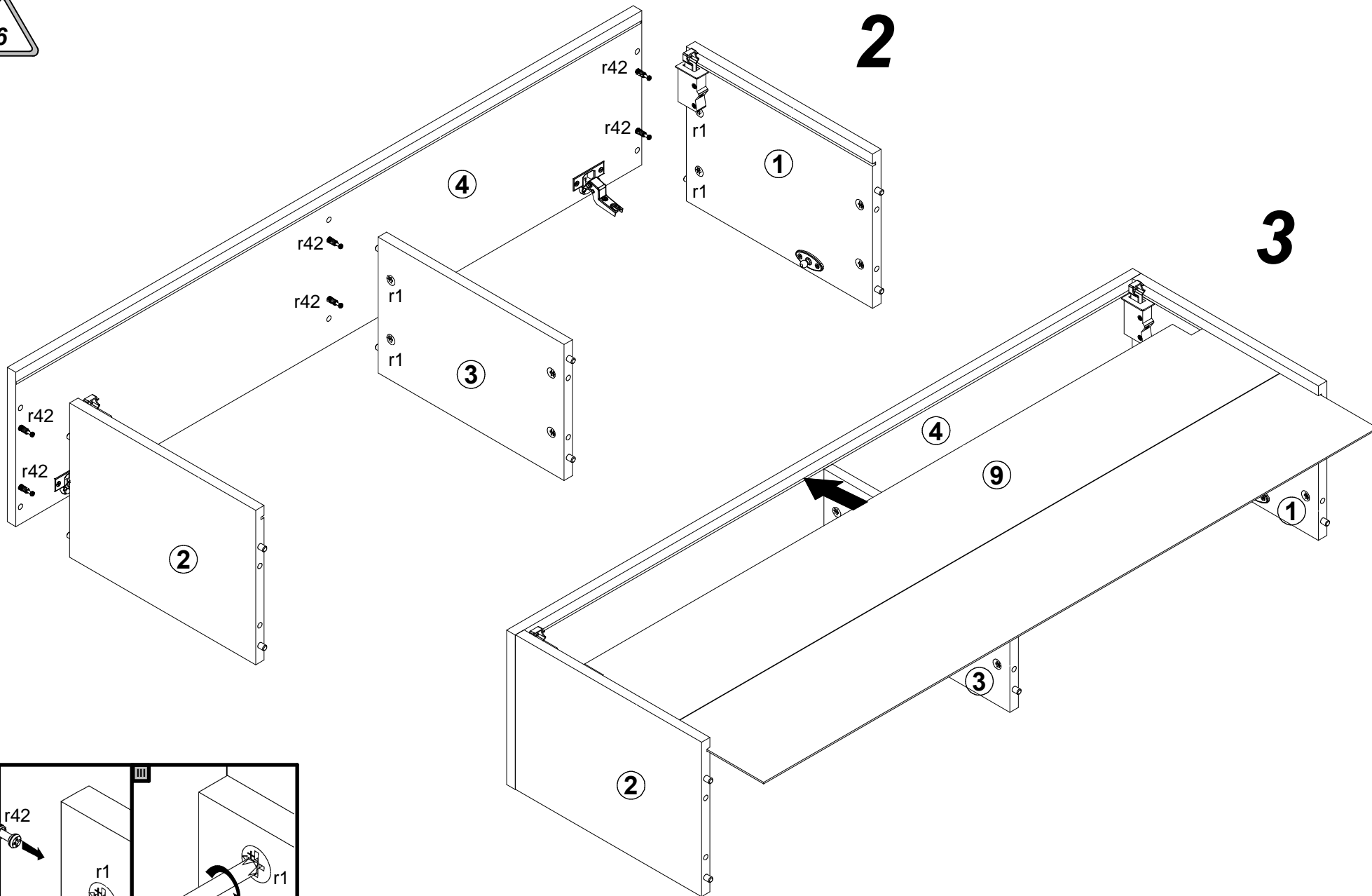



4

5

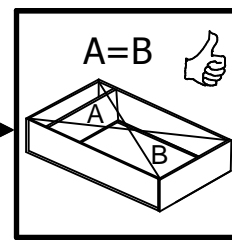
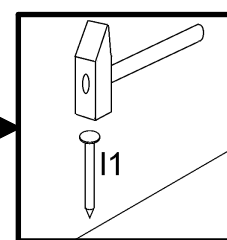
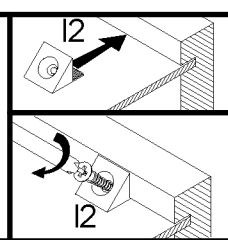
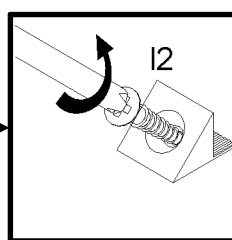
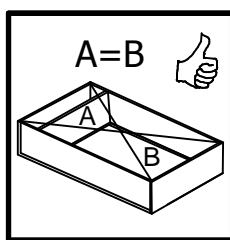
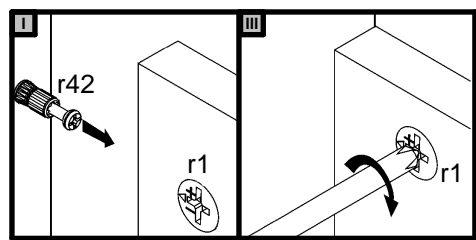
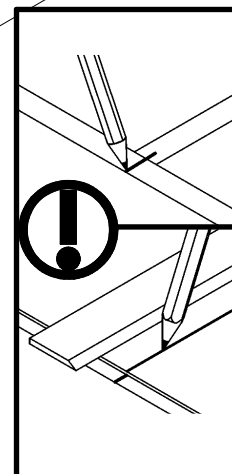
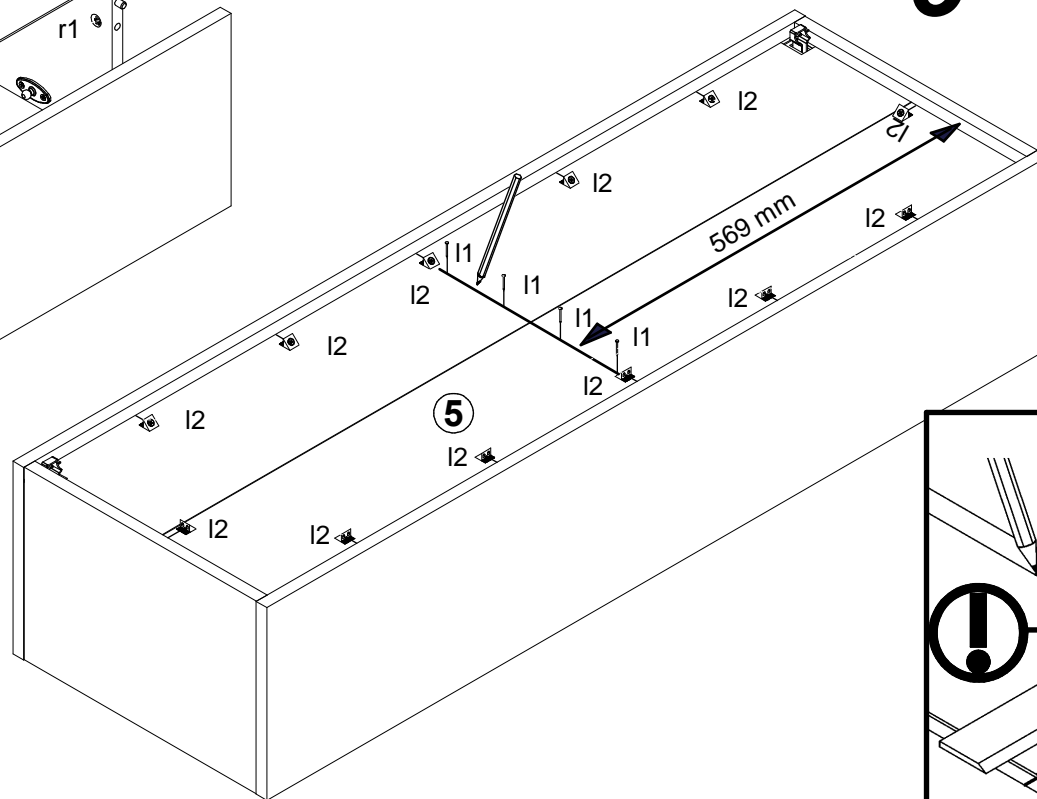
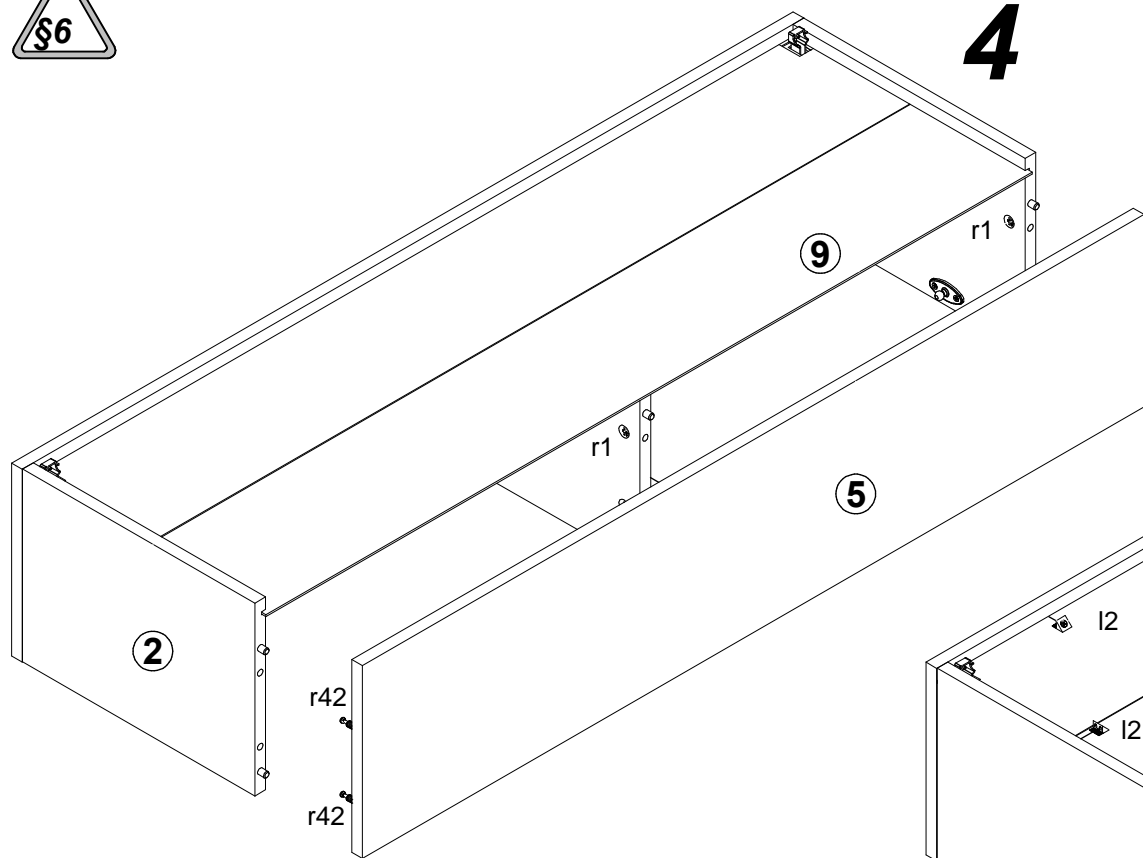

6

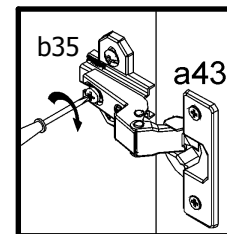
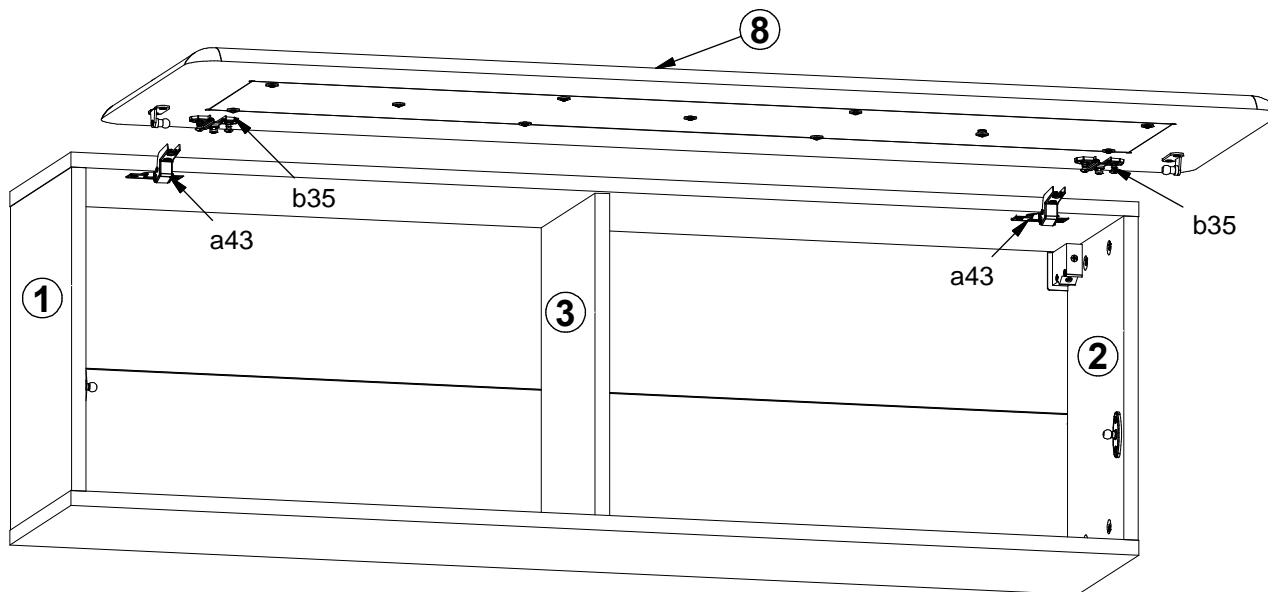

7

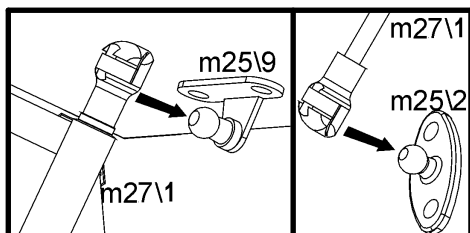
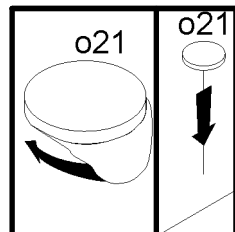
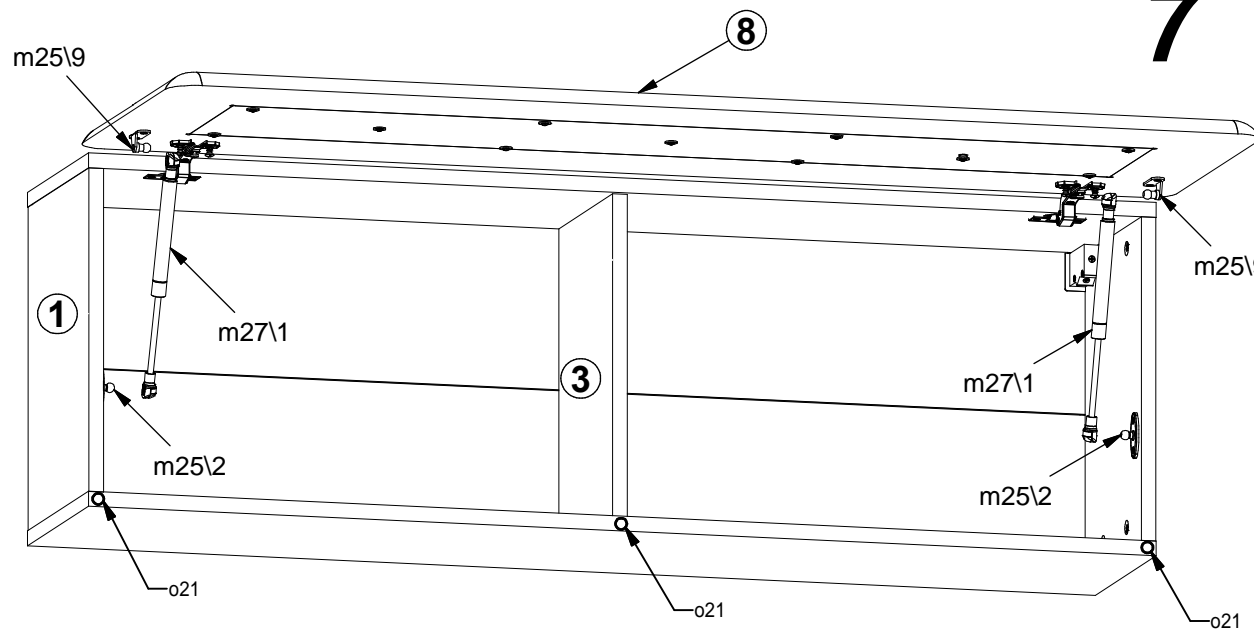



8

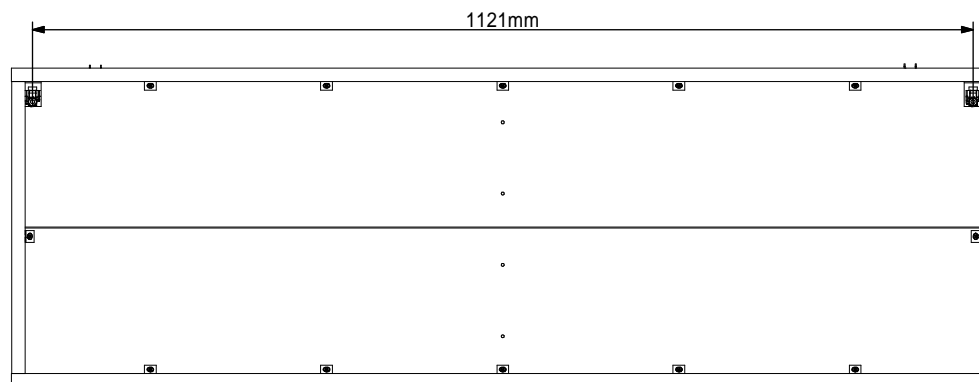
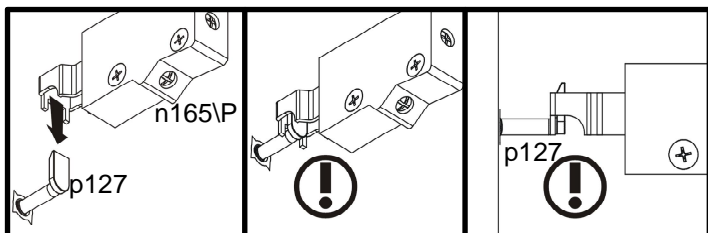
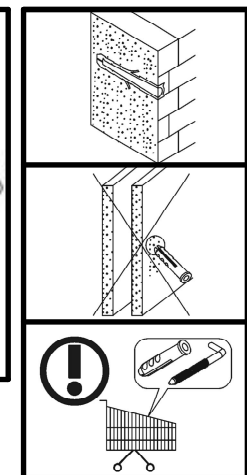
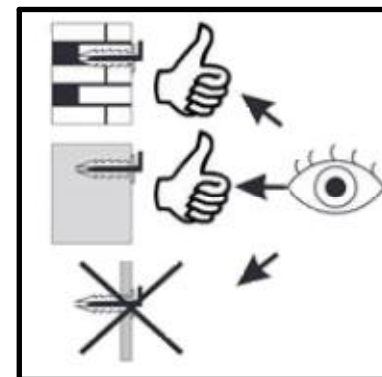
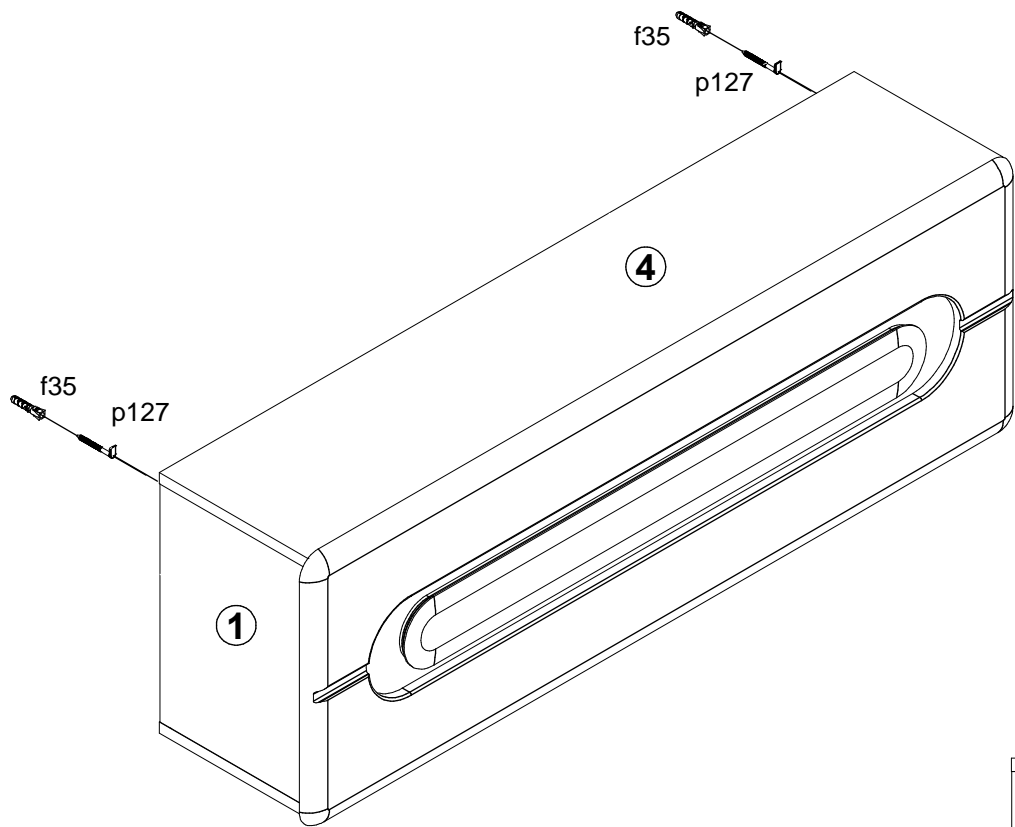
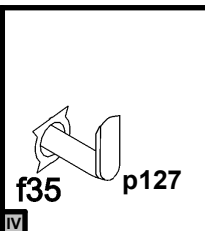
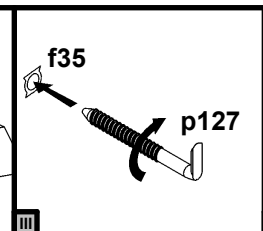
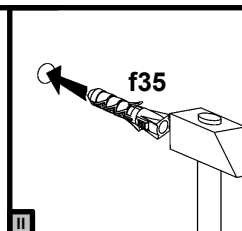
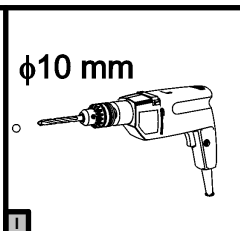
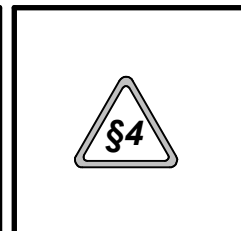
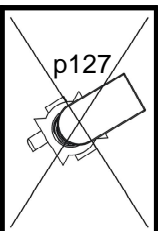
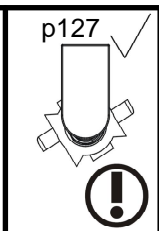
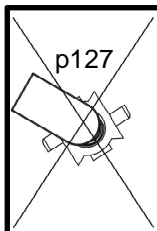



9

